

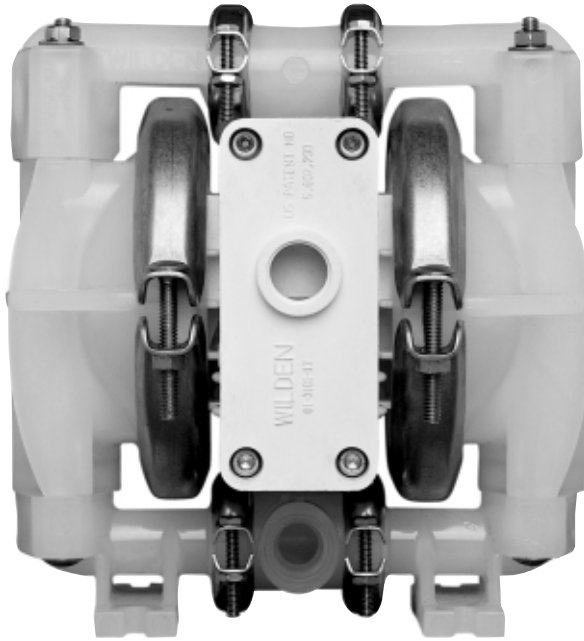

WILDEN®

AIR OPERATED DOUBLE DIAPHRAGM PUMPS

A **DOVER** RESOURCES COMPANY



PROFLO™
PROGRESSIVE PUMP TECHNOLOGY

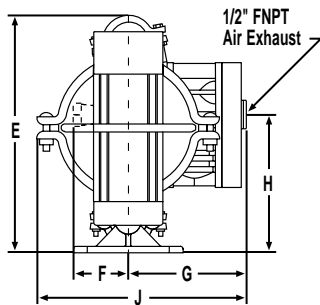
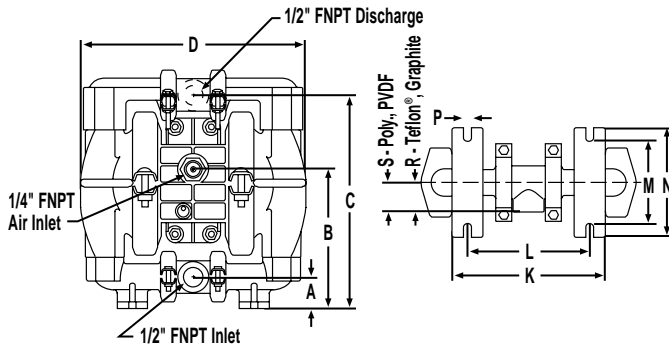

DIMENSIONS - P1 PLASTIC

ITEM	STANDARD (inch)	METRIC (mm)
A	1 5/32	29.3
B	5 1/8	130.2
C	7 11/16	195.3
D	8 3/16	207.8
E	8 5/8	219.1
F	2 5/32	54.8
G	4 17/32	115.1
H	5	127.0
J	8 1/32	204.0
K	5 21/32	143.7
L	4 1/2	114.2
M	3 1/4	82.6
N	4	7.1
P	9/32	7.1
R	27/32	21.4
S	1 3/32	27.8

Refer to the EOM manual for TPE performance curve.

P1 Plastic Pump

FLOW RATE TO 14.8 GPM (56.1 LPM)
MAXIMUM OPERATING PRESSURE = 125 PSI (8.6 BAR)

Specifications

WETTED HOUSINGS (Water Chambers and Manifolds)

MATERIAL	SHIP WT.	MATERIAL	SHIP WT.
Polypropylene	9 lbs. (4.1 kg.)	PVDF	11 lbs. (5.1 kg.)
Carbon-filled Acetal	10 lbs. (4.6 kg.)	Teflon® PFA	12 lbs. (5.5 kg.)

NON-WETTED HOUSINGS

DESCRIPTION	MATERIAL
Center Section	Polypropylene or Acetal

Air Valve Polypropylene or Acetal

MAXIMUM SUCTION LIFT CAPABILITY

DRY LIFT
20' (6.1 m)
The above figure represents the rubber-fitted pump capability.

MAXIMUM DIAMETER SOLIDS

1/16" (1.6 mm) Diameter

ELASTOMER OPTIONS

MATERIAL	TEMPERATURE LIMITS
Polyurethane	+10 (-12.2) to +150 (65.6) F° (C°)
Buna-N®	+10 (-12.2) to +180 (82.2) F° (C°)
Viton®	-40 (-40.0) to +350 (176.7) F° (C°)
Saniflex™	-20 (-28.9) to +220 (104.4) F° (C°)
Teflon® PTFE	+40 (4.4) to +300 (148.9) F° (C°)
Wil-Flex™	-40 (-40.0) to +225 (107.2) F° (C°)

RUBBER-FITTED P1 PLASTIC PUMP

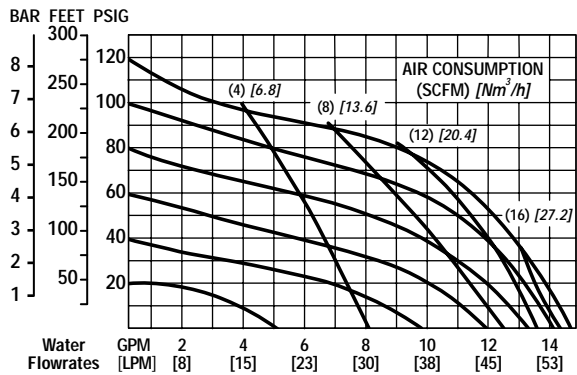

TEFLON® -FITTED P1 PLASTIC PUMP

