

VK/VP SERIES : Sealless Vertical Pump

Assembling Instructions

December 2005



 **WORLD CHEMICAL USA, INC.**
www.worldchemicalusa.com

1. Motor Shaft and Pump Base

- (1) Place a motor on the workbench. A soft cloth or cardboard surface will help protect against paint damage to the fan cover.
- (2) The motor shaft should be upward and a terminal box should be on the opposite side of you.



Motor Shaft
Remove the key from the motor shaft (if supplied) and discard. It will not be used.
Terminal Box

- (3) Attach a NEMA joint shaft to the motor shaft.



Attach the NEMA joint shaft to the motor shaft and tap the top of the NEMA joint shaft lightly until it goes all the way down to the bottom.



- (4) Loosely clamp the jointed shaft with two slit collars.

Place one clamp 10 mm above the base of the motor shaft and place the other at a raised line. Be sure that a locking screw of each slit collar faces diagonally opposite.

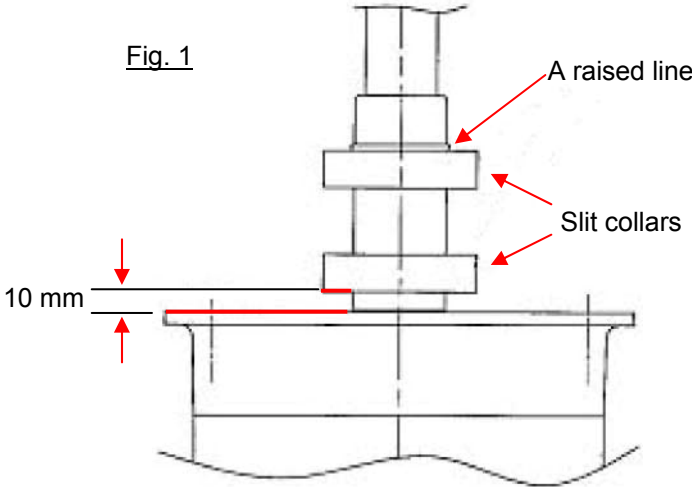

(5) Align the shaft with dial gauge.

- Tighten the slit collars when aligning the shaft, and re-check that the shaft is aligned within 50 μm TIR.



(6) Install the resin bracket.

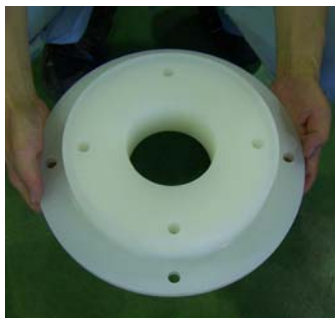

Hexagon Socket Head Bolt Size (Inch)		
41-42VK/VP	3/8-16 x 1-3/4 "L	4 bolts
50-65VK/VP	1/2-13 x 2 "L	4 bolts
How to read bolt size i.e. 1/2-13 x 2 "L 1/2 : Outside diameter of threaded part 13 : Number of pitch per inch 2 : Bolt length from end, excluding end point		

(7) Install the pump base and seal case.

- On the resin bracket is placed the indent should be on the opposite side of the terminal box.
- One of the two holes of the seal case should face the indent of the pump base .

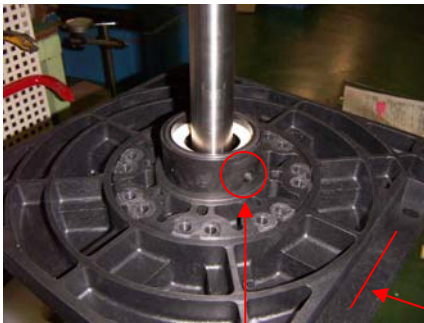

A hole of the seal case

The indent of the pump base

Hexagon Bolt & Washer Sizes for Pump Base (Metric)		
ALL VK/VP	M12 x 35	4 bolts
	M 12	4 washers

2. Connecting Pipe

Install the connecting pipe in such a way that an air-release bolt faces in the same direction of the terminal box.



These parts have to be in the same direction.

Hexagon Bolt & Washer Sizes for Connecting Pipe (Metric)		
ALL VK/VP	M10 x 40	8 bolts
	M10	8 washers

3. Rear Gap

- Tool : Depth gauge
- What to be measured : the depth of the shoulder of a NEMA joint shaft from the surface of a backplate.
- A : Standard depth of backplate's depression, or 6.0 mm
- Allowable error : 1.5 – 2.0 mm
- **Formula : (Measured Value) – 6.0 = Within Allowable Error**
- Shims or spacer rings : Each of 0.2 mm-, 0.3 mm- and 0.5 mm-shims is provided.

Examples

Measured Value	A	Difference	Shim
6.2 mm	6.0 mm	0.2 mm	Use a 0.2mm-shim.
6.5 mm	6.0 mm	0.5 mm	Use a 0.2mm-shim + a 0.3mm-shim, or a 0.5mm-shim.

If the rear gap is beyond the allowable error, re-install a NEMA joint shaft.

Caution : Measure the rear gap without a backplate o-ring.



Fig. 2

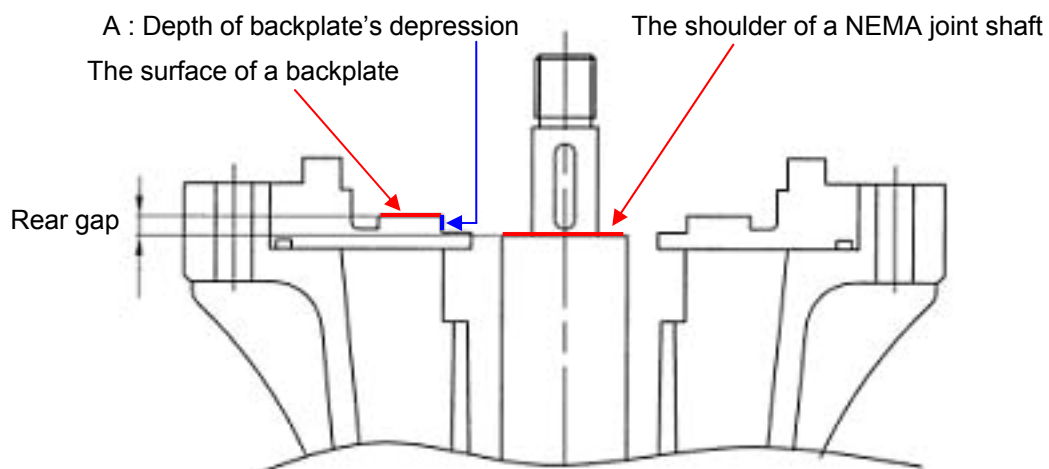

4. Backplate and O-ring

- (1) Backplate o-ring (common in all VK/VP pumps): ISO-265, $\phi 3.8$, EPDM
- (2) Stretch an o-ring until it becomes a little longer than the circumference of the groove of a backplate, place it securely in the groove, and then turn over the backplate to verify the o-ring stays in the groove.



- (3) Place the backplate on the connecting pipe. Make sure that the backplate is level and its lift by the o-ring thickness is 0.7 mm or less from the connecting pipe.

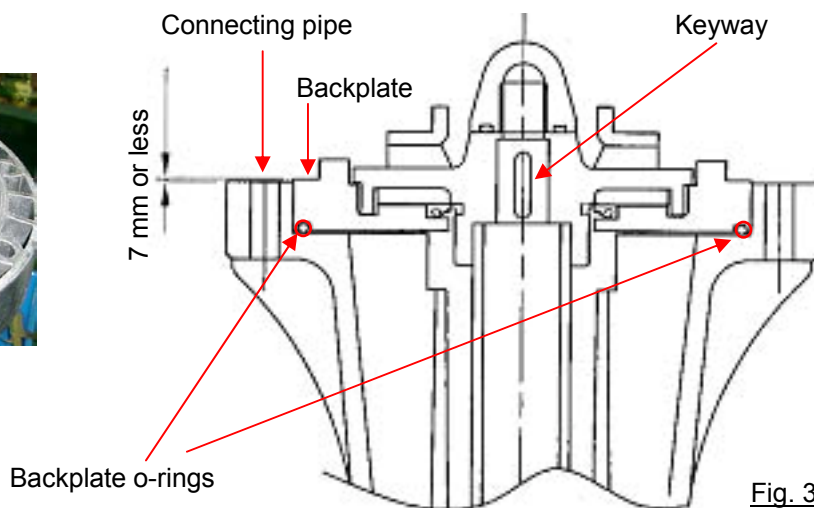

5. Impeller Key

- (1) Dimension: 6 mm x 6 mm x 26 mm 
- (2) Put the impeller key in the keyway.

6. Impeller with Shaft Sleeve

- (1) The impeller height and diameter vary by each pump model.
- (2) Two shaft sleeve sizes: one for 41-50VK/VP pumps; the other for 65VK/VP pumps.

Model	Length of Shaft Sleeve	Inside Diameter
41, 42, 50VK/VP	342.0 mm	φ34
65VK/VP	321.5 mm	φ34

- (3) Put the dry seal on the groove of the shaft sleeve.



Fig. 4

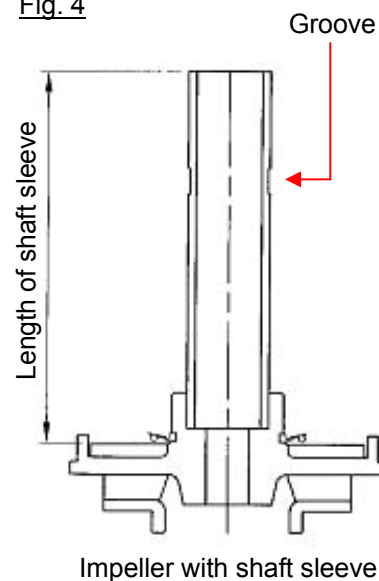

- (4) Place the impeller into the connecting pipe.



- (5) Place a P-24 o-ring in the impeller nut and fasten the shaft with the impeller nut with open-ended spanner that is set at 250 kg-cm or 217 lb-in torque.



Impeller nut



7. Front Gap

- Tool : Depth gauge
- What to be measured :
 - A : The height of the impeller vane from the connecting pipe
 - *B : The depth of the casing
- Allowable error between A and *B : 1.5 – 2.5 mm
- **Formula : *B – A = Within Allowable Error**

Examples for YD-41VK

A	*B	Difference	Allowable Error
19.5 mm	21.5 mm	2.0 mm	Acceptable
18.5 mm	21.5 mm	3.0 mm	Not acceptable
Measure several different measuring points to verify the front gap is within the allowable error.			

*B	
Model	Standard Depth of Casing (mm)
41VK-16	21.5
41VK-26	21.5
42VK-36	24.5
50VK-55/56	24.5
65VK-55/56	25.5
65VK-7.55	27.5
65VK-7.56	25.5
65VK-106	27.5
50VP-35/36	20.5
50VP-55	21.5
50VP-56	20.5
65VP-105/106	27.5

A : The height of the impeller vane from the connecting pipe

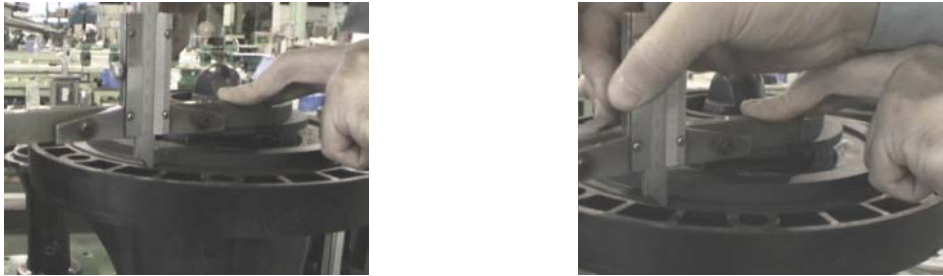
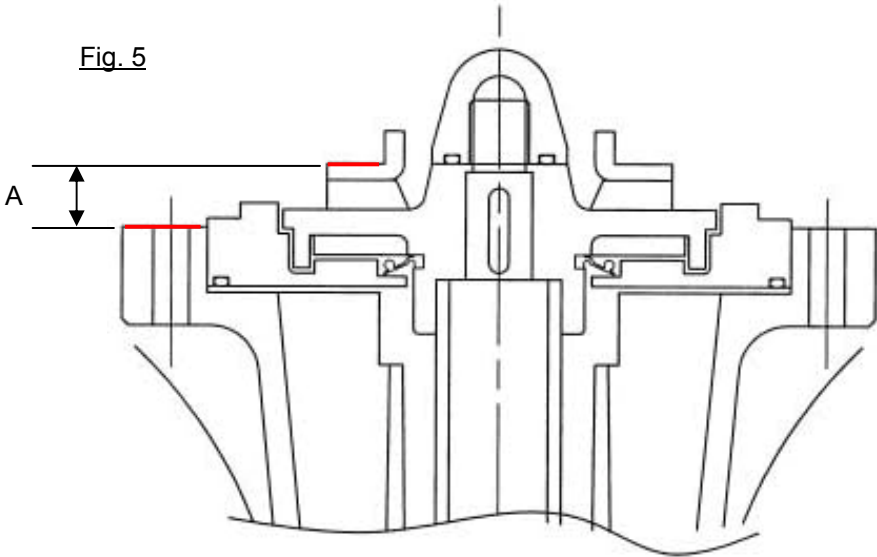

Fig. 5



*B : The depth of the casing



Fig. 6

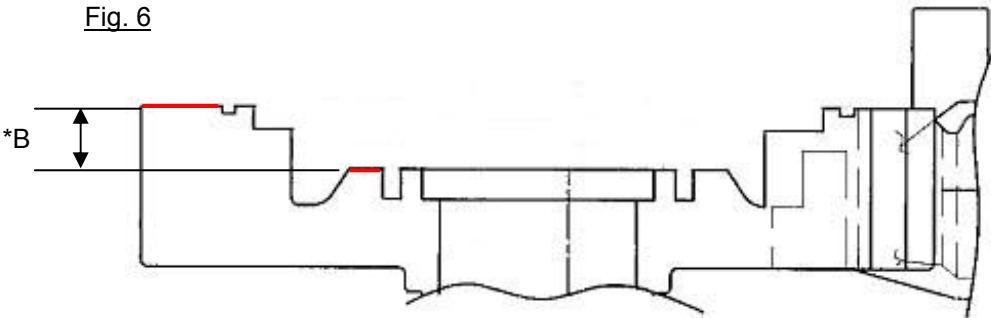

8. Casing

- (1) Place an o-ring (ISO-265) in the groove of the casing.



- (2) Place the casing on the connecting pipe. Make sure that the casing flange faces in the same direction of the indent of the pump base.

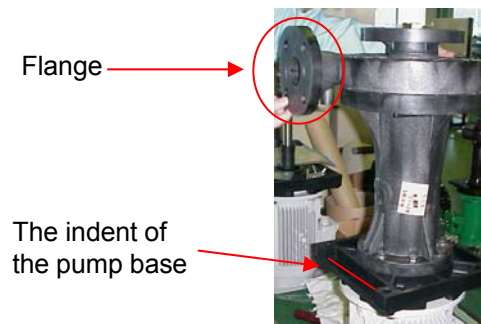

- (3) Verify the o-ring stays in the casing by viewing the gap between the casing and the connecting pipe. If there is too much gap, the o-ring may not be securely placed in the casing.

Gap between the casing and
the connecting pipe



- (4) Temporarily fasten the casing at two points that diametrically opposite each other with 1 bolt + 2 washers + 1 nut---a spring washer is not needed for temporary tightening. For the rest of six bolt holes, fasten the casing with 1 bolt + 2 washers + 1 spring washer + 1 nut. After finishing fastening six bolts, re-fasten the temporary tightening in the same manner as the six bolts.

Part Name	Size (Metric)	Qty (8 sets)
Bolt (SUS B)	M10 x 95	8
Washer	M10	16
Spring Washer	M10	8
Nut	M10	8

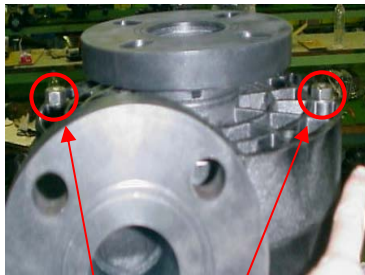

Temporary tightening
1 bolt+ 2 washers+1 nut



Tighten the rest of six bolt holes
1 bolt+ 2 washers+1 spring+1 nut

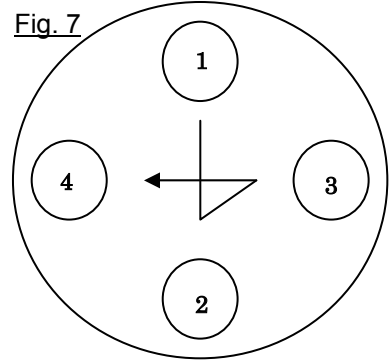

Fig. 7

Tighten bolts diagonally in the sequence shown above.

- (5) After installing the casing, put your hand in the casing from above and turn the impeller to see if it turns smoothly. If the impeller does not turn smoothly, it may be contacting other parts. Remove the bolts and re-install the impeller properly.



Air-release bolt with gasket

9. Air-release Bolt

Install one hexagonal air-release bolt (M12 x 25) with gasket to the connecting pipe.