

SLC 1 - SLC 2 - SLC 3 PUMPS

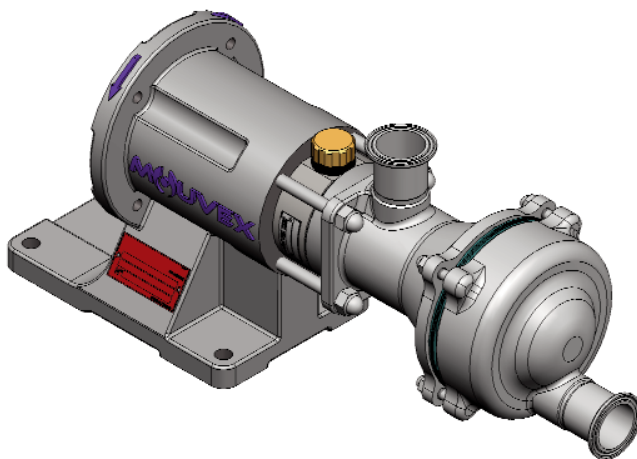

INSTALLATION

OPERATION

MAINTENANCE

ECCENTRIC DISC PUMP MOUVEX PRINCIPLE

SAFETY INSTRUCTIONS, STORAGE, INSTALLATION AND MAINTENANCE

MODELS : SLC 1 - SLC 2 - SLC 3

TECHNICAL CHARACTERISTICS

- Maximum pump speed : **1000 rpm**
- Maximum running temperature :
 - seals FKM/FEP - FKM
 - * continuous110°C
 - * washing/rinsing/sterilisation121°C
- Maximum suction pressure :
 - In normal use, the suction pressure must be higher than the required NPSH and **less than 1,5 bar** (21,7 psi).
 - During pump **CIP/SIP**, the suction pressure must not exceed **3 bar**.(43.5 psi).
 - With pump **stopped**, the pressure must not exceed **6 bar**.(87 psi).
- Maximum differential pressure :
 - SLC 116 bar* (232 psi)
 - SLC 210 bar* (145 psi)
 - SLC 36 bar* (87 psi)
- Displacement :
 - SLC 10,017 liter
 - SLC 20,034 liter
 - SLC 30,051 liter
- Volume :
 - Suction0,43 liter
 - Discharge0,16 liter
 - Total0,59 liter (0,036 US gallons)

* When the pump works with an inlet pressure less than zero, the maximum outlet pressure will be calculated as if the inlet pressure is equal to zero.

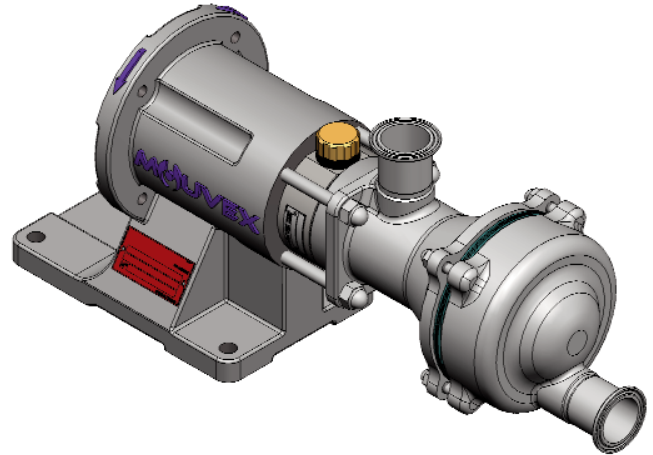

Pump N° :

Effective date :

SAFETY INFORMATIONS



This is a SAFETY ALERT SYMBOL

When you see this symbol on the product, or in the manual, look for one of the following signal words and be alert to the potential for personal injury, death or major property damage.



Warns of hazards that **WILL** cause serious personal injury, death or major property damage



Warns of hazards that **CAN** cause serious personal injury, death or major property damage.



Warns of hazards that **CAN** cause personal injury or property damage.

NOTICE

Indicates special instructions which are very important and must be followed.

SUMMARY

Page

1. OVERALL DIMENSIONS	3
2. INSTALLATION	10
2.1 Orientation of the pump ports	10
2.2 Direction of rotation	10
2.3 Protection of the installation and the pump	10
2.4 Unit Assembly	11
3. USE	13
3.1 Noise level	13
3.2 Commissioning	13
3.3 Dry running	13
3.4 Stopping the pump	13
3.5 Bellows monitoring	13
4. CLEAN IN PLACE (CIP) & STERILISATION IN PLACE (SIP) 14	
4.1 General	14
4.2 CIP circuit recommended	14
4.3 Pumps arranged in series	14
4.4 Pumps arranged in parallel	15
4.5 Successive cycles	16
4.6 Sterilisation in place (SIP)	16
5. MAINTENANCE	17
5.1 Necessary tools	17
5.2 Pump disassembly	18
5.3 Checking the cylinder/piston torque	19
5.4 Reassembling the pump	19
5.5 Transmission disassembly/reassembly	21
6. CHECKING THE BELLOWS	21
7. DRAINING THE BEARING	22
8. OPTIONS	22
8.1 Bellows monitoring system	22

1. OVERALL DIMENSIONS

Pumps SLC1 - SLC2 - SLC3 with connections

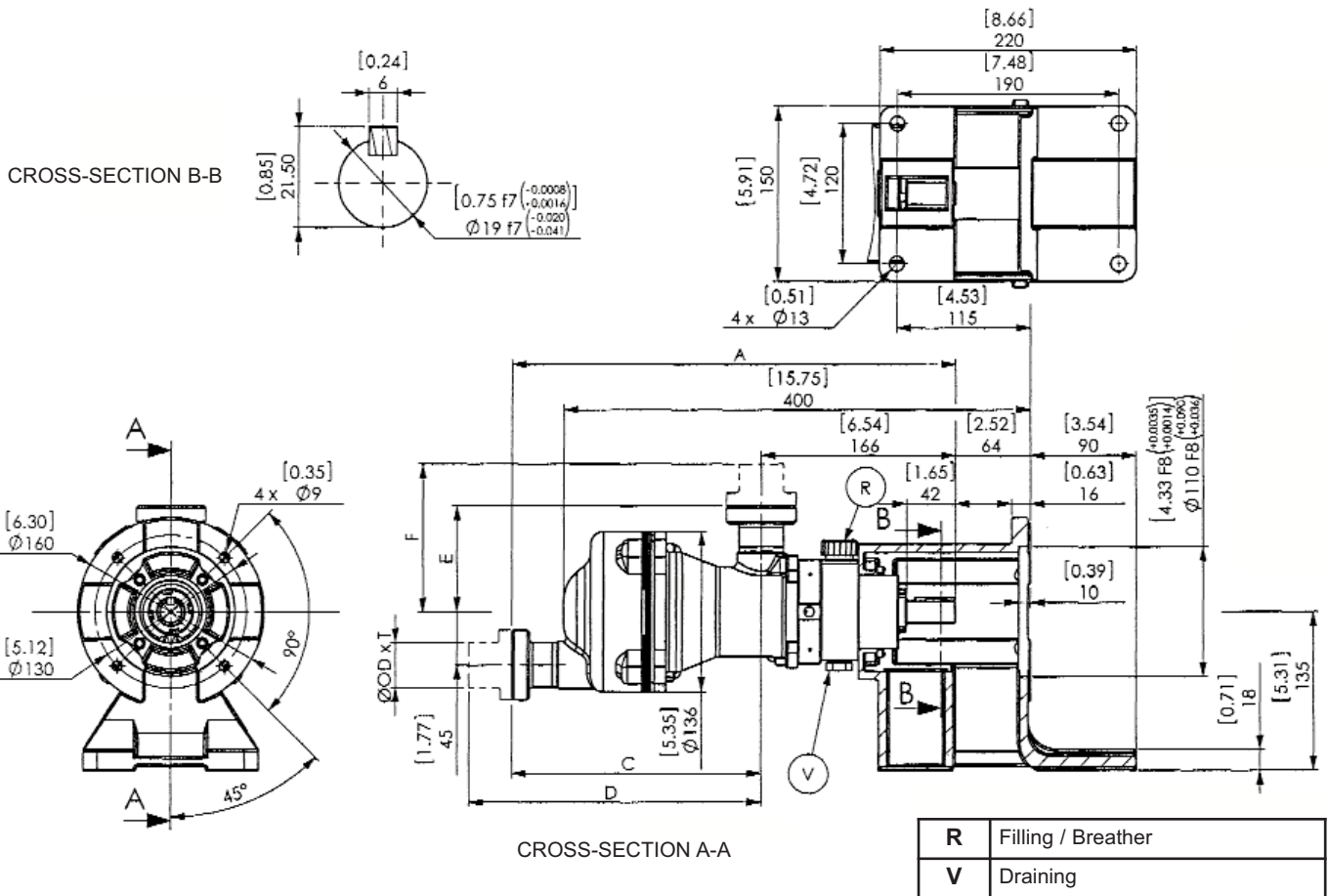

Connections								
	DN	A	C	D	E	F	ØOD x T	Weight kg [lb]
SMS 1145	38 [1.496]	380.5 [14.98]	214.5 [8.445]	235 [9.252]	90 [3.543]	110 [4.331]	38 x 1.25 [1.496 x 0.049]	19 [42]
Clamp (ISO 2852)	38 [1.496]	380.5 [14.98]	214.5 [8.445]	235 [9.252]	90 [3.543]	110 [4.331]	40.6 x 1.5 [1.598 x 0.059]	19 [42]
RJT (BS 4825-5)	38 [1.496]	380.5 [14.98]	214.5 [8.445]	224.5 [8.839]	90 [3.543]	100 [3.937]	38.35 x 1.725 [1.51 x 0.068]	19 [42]
FIL-IDF (ISO 2853)	38 [1.496]	380.5 [14.98]	214.5 [8.445]	235 [9.252]	90 [3.543]	110 [4.331]	38.6 x 1.5 [1.52 x 0.059]	19 [42]
Cherry Burrel	38 [1.496]	380.5 [14.98]	214.5 [8.445]	235 [9.252]	90 [3.543]	110 [4.331]	38.1 x 1.65 [1.5 x 0.065]	19 [42]
DIN 11851	40 [1.575]	380.5 [14.98]	214.5 [8.445]	235 [9.252]	90 [3.543]	110 [4.331]	43 x 2.5 [1.693 x 0.098]	19 [42]
Smooth end-fitting*	38 [1.496]	385.5 [15.177]	219.5 [8.642]	-	95 [3.74]	-	38 x 1.5 [1.498 x 0.059]	19 [42]

* CAUTION : When welding the connections, the below should be protected.

1. OVERALL DIMENSIONS (continued)

Pumps SLC1 - SLC2 - SLC3 with flanges

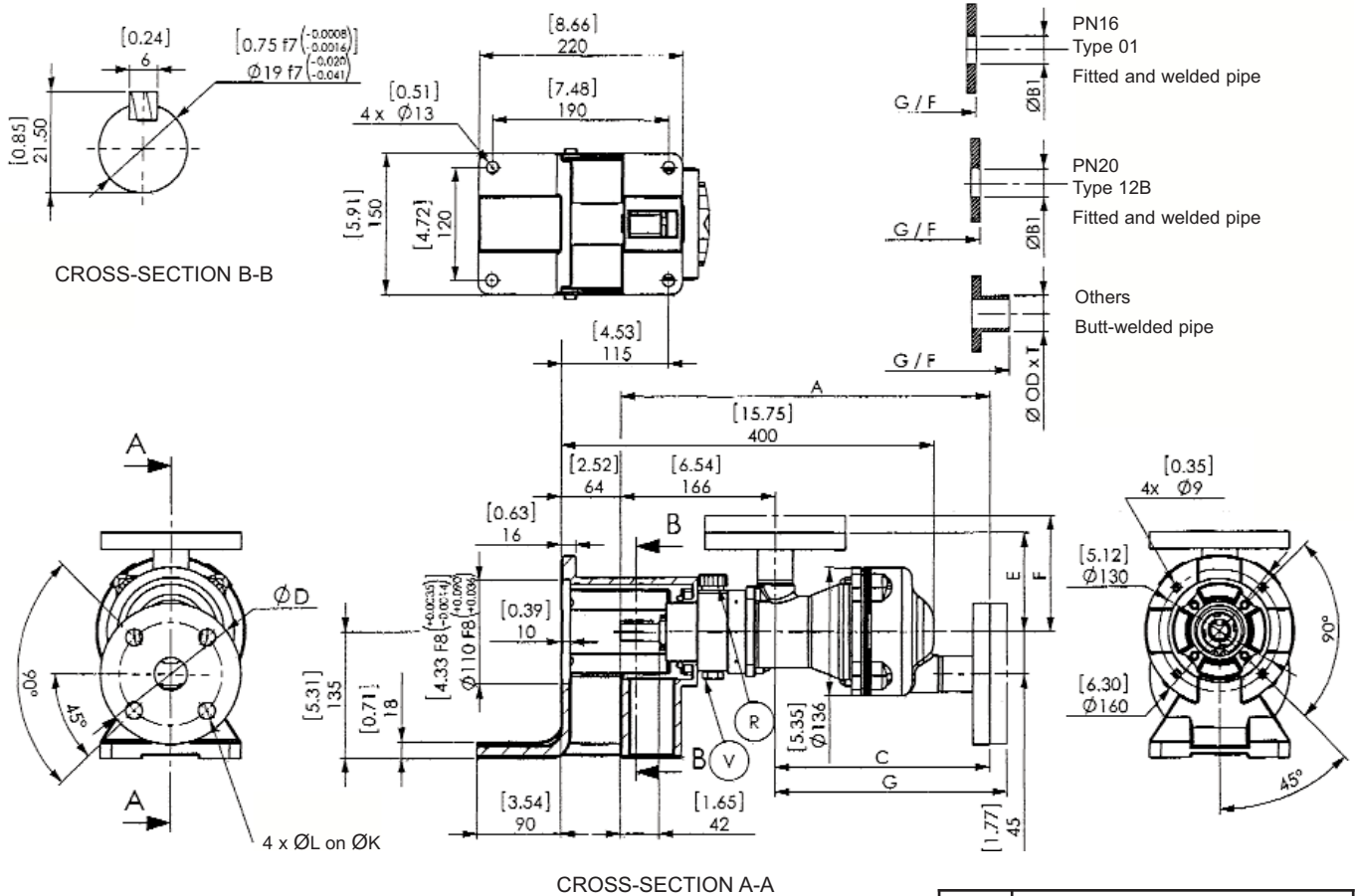

R	Filling / Breather
V	Draining

Flanges												
	DN	A	C	ØD	E	F	G	ØOD x T	ØL	ØK	ØB1	Weight kg [lb]
PN16 (ISO 7005-1)	40	395.5 [1.575]	229.5 [9.035]	150 [5.906]	105 [4.134]	123 [4.843]	247.5 [9.744]	- x - - x -	18 [0.709]	110 [4.331]	49.5 [1.949]	23 [51]
PN20 (ISO 7005-1)	40	395.5 [1.575]	229.5 [9.035]	130 [5.118]	105 [4.134]	127 [5]	251.5 [9.902]	- x - - x -	16 [0.63]	98.5 [3.878]	49.5 [1.949]	23 [51]
Connect-S® *	40	399.5 [1.575]	233.5 [9.193]	115 [4.528]	109 [4.291]	161 [6.339]	285.5 [11.24]	41 x 1.5 [1.614 x 0.059]	15 [0.591]	85 [3.346]	- -	23 [51]
DIN 11864 BF-A-DN40	40	380.5 [1.575]	214.5 [8.445]	82 [3.228]	90 [3.543]	114 [4.488]	238.5 [9.39]	41 x 1.5 [1.614 x 0.059]	9 [0.354]	65 [2.559]	- -	23 [51]

* Connect-S® is a registered trademark owned by NEUMO.

1. OVERALL DIMENSIONS (continued)

Pumps SLC1 - SLC2 - SLC3 with pressure switch

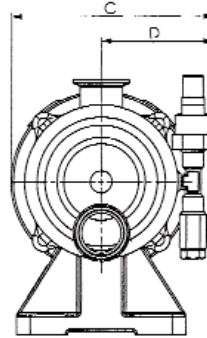
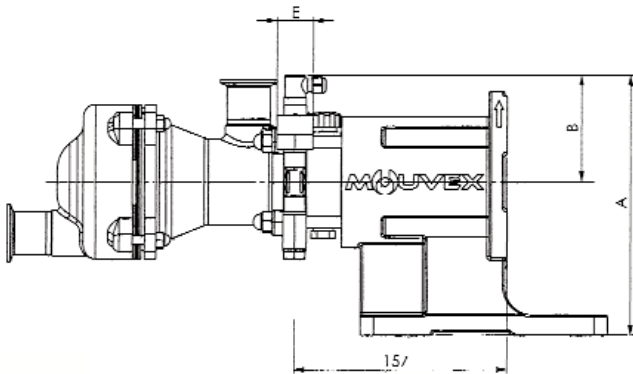

If the suction port is in position 1 :
The transmission is rotated by 180° and the detection system is installed on the right (as seen from the shaft end).

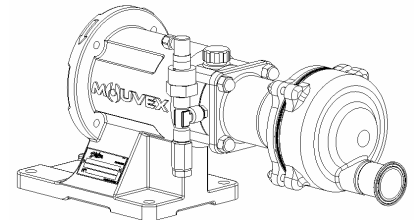
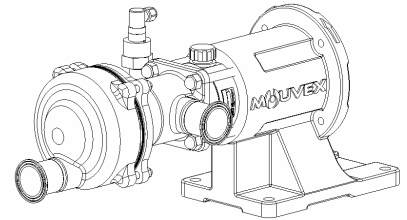

NOTE :

For the other dimensions, refer to the pump overall dimension drawing.
The detection bearings are adjusted in the plant and should not be modified.
The transmission may only be dismantled in the plant.

CAUTION :

Incorrect connection can lead to :
- a flammability risk,
- ineffective monitoring,
- possible damage to the sensor.

ATEX pressure switch	Standard pressure switch	
Connection diagram	Rupture detection	Normal operation
<p>Ex-Zone 1 or 2, 21 or 22 Microswitch ZF 213, 513</p> <p>Output</p> <p>Supply voltage</p> <p>Ex-free Zone</p>	<p>(-) 0</p> <p>(+) 10-30 Vdc / I max : 100 mA</p>	<p>(-) 0</p> <p>(+) 10-30 Vdc / I max : 100 mA</p>

PRESSURE SWITCH						
	A	B	C	D	E	Pressure switch weight kg [lb]
Standard pressure switch	230 [9,055]	95 [3,74]	178 [7,008]	98 [3,858]	32 [1,26]	0,45 [1]
ATEX pressure switch	371 [14,606]	234 [9,213]	192 [7,559]	112 [4,409]	74 [2,913]	0,888 [2]

1. OVERALL DIMENSIONS (continued)

Pumps SLC1 - SLC2 - SLC3 with pressure gauge

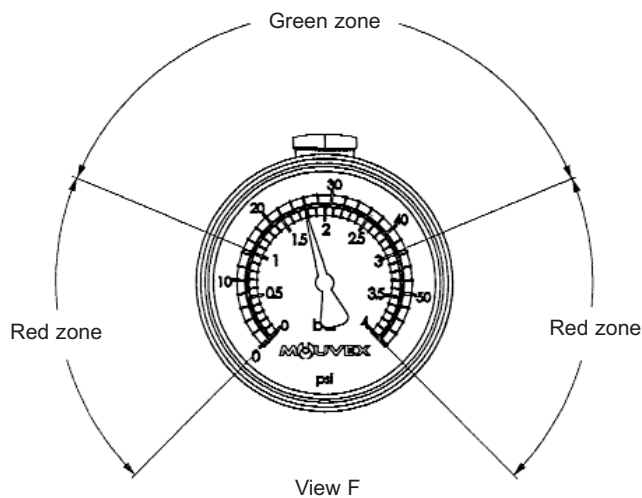
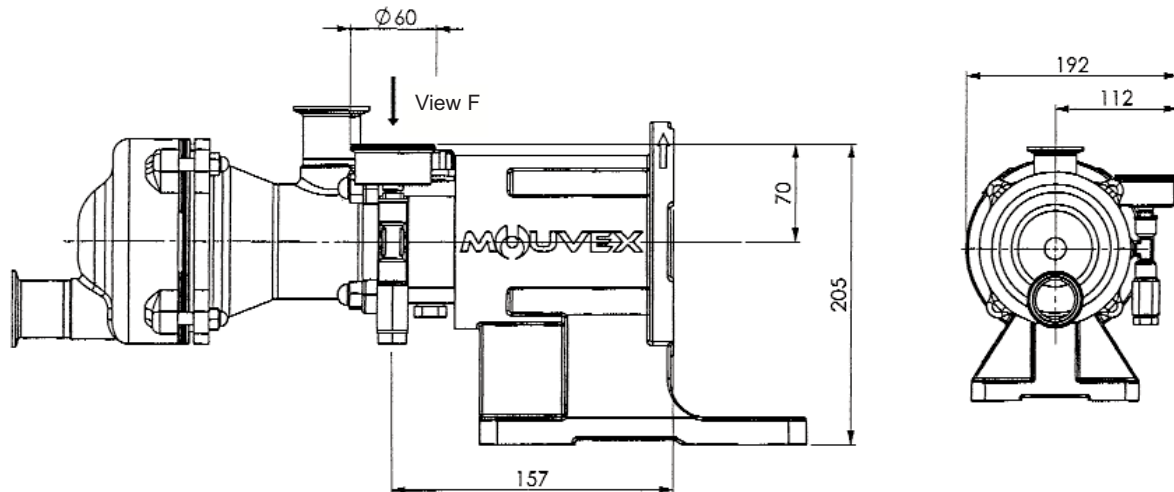

If the suction port is in position 1 :
The transmission is rotated by 180° and the detection system
is installed on the right (as seen from the shaft end).

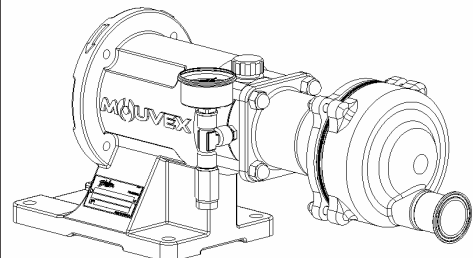
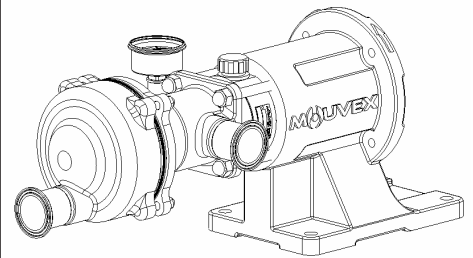

NOTE :

For the other dimensions, refer to the pump overall dimension drawing.
The detection bearings are adjusted in the plant and should not be modified.
The transmission may only be dismantled in the plant.
Weight added to the pump : 0,5 kg

1. OVERALL DIMENSIONS (continued)

Pumps SLC 1 - SLC 2 - SLC 3

Heating jacket

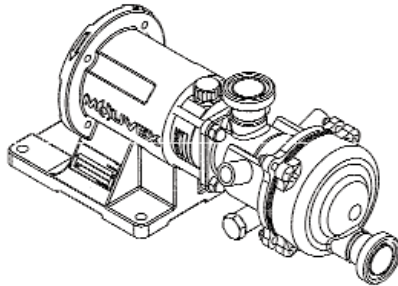
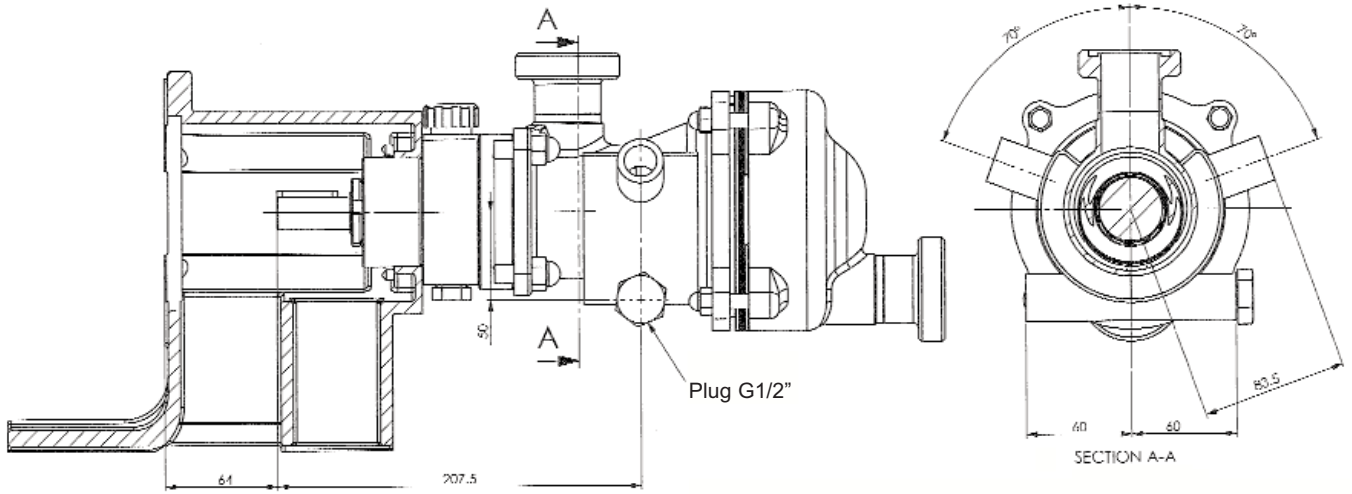

NOTICE :

For the other sides, see the specific overall dimension plan for the connection.

Maximum jacket pressure : 8 bar (116 psi).

Maximum jacket temperature : FKM and FEP encapsulated FKM seals : 180°C.

CAUTION :

The pumped product must not exceed the temperature of 110°C.

FOR ATEX PUMPS, SEE INSTRUCTIONS NR 1050.

POSITION OF INLET CONNECTION : 2 (Standard) CONNECTION 1/2" B.S.P.F		
STEAM		OR
The entry connection may be connected to one or two points.		
LIQUID		OR
The exit connection may be connected to one or two points. If it is done at 1 point, purge the air at the second point.		
STEAM	POSITION OF INLET CONNECTION : 3	POSITION OF INLET CONNECTION : 1
LIQUID		

Connection

POSITION OF INLET CONNECTION : 4	
STEAM	OR
The exit connection may be connected to one or two points. If it is done at 1 point, purge the water at the second point.	
LIQUID	OR
The entry connection may be connected to one or two points. If it is done at 1 point, the warming up process will be less effective.	

1. OVERALL DIMENSIONS (continued)

Pumps SLC1 - SLC2 - SLC3 Exploded view

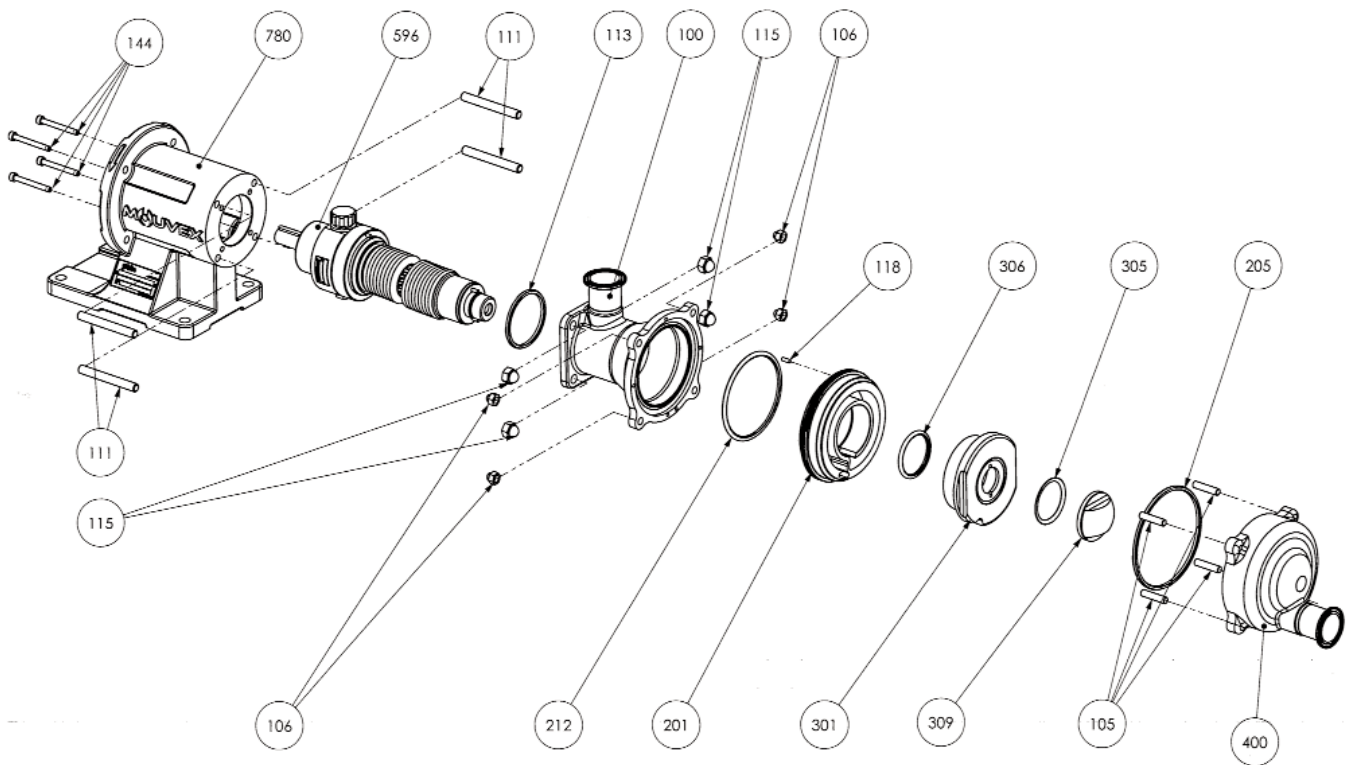

2. INSTALLATION

		POSSIBLES POSITIONS			
INLET	1.	2. STANDARD	3.	4.	
OUTLET	1.	2.	3.	4. STANDARD	

The SLC pump is a self-priming volumetric PD pump.

Therefore, the pump must not run on a circuit with a closed valve. This is valid both for the suction circuit and for the discharge circuit.

The pump is designed to be attached to the end of a motor; during assembly ensure that the half couplings are tightly and securely closed.

2.1 ORIENTATION OF THE PUMP PORTS

The suction port and the discharge port may be oriented in various positions.

If, at installation, the positions of the ports have to be modified, refer to the PUMP DISASSEMBLY AND REASSEMBLY section.

NOTE

SLC pumps remain drainable whatever the chosen position of the suction port. However, the discharge port must be at the bottom (position 4) in order to ensure drainability.

2.2 DIRECTION OF ROTATION

When looking at the shaft, the rotation will be clockwise. An arrow situated on the lantern ring indicates the correct direction of rotation.

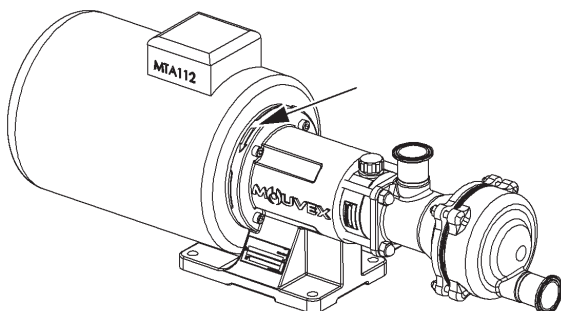

Verification of the correct rotation direction :

Run the pump at low speed.

Note : Running the pump in reverse will not damage it.

2.3 PROTECTION OF THE INSTALLATION AND THE PUMP

- For ease of maintenance, it is a good idea to place isolation valves before and after the pump. The sizing of these valves must correspond to the diameter of the pipes.
- Before any start-up or complete stopping of the pump, make sure the valves are open.
- During stop periods, with the pump full of product, either the suction or discharge circuit must be left open to enable expansion or contraction of the pumped product through reheating or cooling. If this instruction is not complied with, the bellows may be damaged and lead to premature failure.
- The bearing must remain ventilated. The breather mounted on the bearing must therefore be used. Never fit the bung.
- The stop time may lead to cooling of the product in the pump and therefore to an increase in viscosity. If this is the case, we recommend re-starting the pump at a speed adapted to this new viscosity (starting pump). Once the product arrives in the pump at the installation definition temperature, the pump may run at the speed specified for this application.
- Protection against excess pressure :
The pump must be protected against excess pressure. It can be delivered with a pressure switch to carry out.
If protection is provided by a control valve, check that the system does not generate excess pressure at the bellows (particularly if there are water hammers). This type of operation could damage the bellows and shorten its service life.

2. INSTALLATION (continued)

⚠ WARNING



INCORRECT SETTINGS OF THE PRESSURE RELIEF VALVE CAN CAUSE PUMP COMPONENT FAILURE, PERSONAL INJURY, AND PROPERTY DAMAGE.

Hazardous pressure can cause personal injury or property damage.

⚠ WARNING



FAILURE TO INSTALL ADEQUATELY SIZED PRESSURE RELIEF VALVE(S) CAN CAUSE PROPERTY DAMAGE, PERSONAL INJURY OR DEATH.

Hazardous pressure can cause personal injury or property damage.

⚠ WARNING



PUMPS OPERATING AGAINST A CLOSED VALVE CAN CAUSE SYSTEM FAILURE, PERSONAL INJURY AND PROPERTY DAMAGE.

Hazardous pressure can cause personal injury or property damage.

• Protection against particles :

The pump and the installation must also be protected against any risk of damage through the passage of foreign bodies, by mounting a pre-filter at the pump suction.

In the event of foreseeable clogging of the pre-filter, we recommend using a vacuum switch to inform the user of pre-filter clogging. Prolonged running under cavitation may damage the pump.

The largest dimensions of the allowable particles in the pump are :

- Soft particles : 4 mm
- Hard particles : 2 mm

2.4 UNIT ASSEMBLY

The following instructions apply to pumps delivered with a bare shaft and the bended bracket.

2.4.1 INSTALLATION OF UNITS

⚠ WARNING



BE CAREFUL WITH THE WEIGHT OF THE PARTS WHEN THEY ARE BEING REMOVED.

The weight of the parts can be dangerous and may provoke bodily injuries or material damages.

⚠ WARNING



DISCONNECT THE ELECTRICITY SUPPLY BEFORE ANY MAINTENANCE OPERATION.

Dangerous voltage. Can cause injury and death.

The base below the unit is fundamental to ensuring correct operation and long service life.

The unit's base must be flat, level and sufficiently resistant to absorb the stresses caused by the motor-driven pump unit without deformation (if it is made of concrete, it must comply with the BAEL 91 standard).

If the unit is fastened using securing lugs or bolts, it must be carefully wedged to avoid deforming the frame while the bolts are tightened. A deformed frame would apply damaging stresses on the pump and the drive mechanism and misalign the coupling, causing vibrations, noise and premature wear. Ensure that the frame is well above the floor, except from the support plates.

If the unit is to be used in a food environment, support plates that allow the unit to be lifted for easier cleaning are recommended.

Allow, if possible, a clear space of approximately 50 cm on each side of the motor-driven pump unit (overall dimensions) to facilitate cleaning and give access if necessary to the pump, reduction gear and motor fastening nuts. In all cases, the dimensions around the motor-driven pump unit must be designed to give the space required for dismantling the pump (if the need arises, use the values given on the overall dimension drawing).

For staff and equipment protection, the frame includes a ground connection point that should be used.

2. INSTALLATION (continued)

2.4.2 ALIGNMENT OF THE MOTOR/PUMP OR REDUCTION GEAR/PUMP SHAFTS

⚠ WARNING



Do not operate without guard in place.

IF OPERATED WITHOUT THE SHAFT GUARD, THERE IS CONSIDERABLE RISK OF SEVERE PERSONAL INJURY, SIGNIFICANT PROPERTY DAMAGE OR EVEN DEATH

⚠ WARNING



Dangerous voltage. Can cause injury and death.

DISCONNECT THE ELECTRICITY SUPPLY BEFORE ANY MAINTENANCE OPERATION.

NEVER START A UNIT IF THE COUPLING ALIGNMENT IS INCORRECT. THIS IS A CONDITION OF OUR GUARANTEE.

REMINDER :

Coupling must never be used to compensate for a misalignment.

To control the alignment between the coupling and the shaft, use a straight-edge for concentricity and thickness gauges for angular misalignment (see instructions of the coupling for authorised values).

The 3 figures below show in detail the operation and the possible defects :

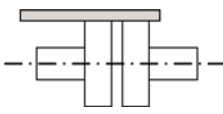
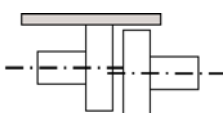
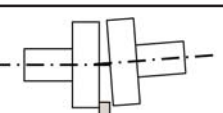
<i>Make this check for 4 points : up - down - left - right</i>	
	<i>Correct</i>
	<i>Out-of-parallelism</i>
	<i>Angular defect</i>

Controlling the alignment at each stage of the installation is important to be sure that none of these stages have generated stresses on the unit or the pump :

- after fastening on the foundations
- after fastening the pipes
- after the pump has been operated at the normal operating temperature

Where the pumps are supplied assembled as a unit, the motor and pump shafts have been perfectly aligned in the factory before delivery, but they must be systematically controlled on acceptance at the site and realigned if necessary.

To do this, do not modify the wedging of the various parts, but check the flatness of the support surface and use the adjustable foot to clear the frame of stresses that could affect it.

2.4.3 ELECTIC MOTORS

⚠ WARNING



Dangerous voltage. Can cause injury and death.

DISCONNECT THE ELECTRICITY SUPPLY BEFORE ANY MAINTENANCE OPERATION.

Check the compatibility of the instructions on the motor with the supply voltage.

Follow the wiring diagram, use wiring that is appropriate for the power and be particularly careful about the contacts which must be well tightened.

The motors should be protected with circuit breakers and suitable fuses. Connect the regulatory electrical grounding.

2. INSTALLATION (continued)

2.4.4 CONTROL OF THE SENSE OF ROTATION

 WARNING
Any unforeseen start-up can cause serious injuries or important material damages.

TAKE ALL NECESSARY MEASURES TO RENDER ANY START-UP, EVEN ACCIDENTAL, OF THE PUMP DURING THE WORK IMPOSSIBLE.

 WARNING
Hazardous pressure can cause personal injury or property damage.

IT IS IMPERATIVE THAT THE HYDRAULIC PRESSURE IS RELEASED BEFORE EACH MAINTENANCE OPERATION TO AVOID PERSONAL INJURY OR MATERIAL DAMAGE

This pump can contain test product residues. If necessary, clean the pump before using it.

 WARNING
Do not operate without guard in place.

A DRIVE SHAFT GUARD BETWEEN THE PTO AND PUMP MUST BE PROVIDED TO PREVENT PERSONAL INJURY, PROPERTY DAMAGE, OR DEATH.

This control needs to be done with no liquid pumped through the pump, and both the suction and discharge circuits venting to avoid generating unexpected pressure (at the suction side, for example). This will ensure that the control will not damage either the pump or the installation.

Start the pump empty to check that the connections are good and that the direction of rotation corresponds to the suction and discharge direction on the installation. If it is necessary to reverse the direction of rotation, follow the instructions below :

Three-phase motor : switch any 2 current input wires.

Bi-phase motor : switch two same phase wires.

Single-phase motor : follow the instructions on the notice supplied with the motor.

3. USE

3.1 NOISE LEVEL

The sound level of a pump is greatly influenced by its conditions of use. Cavitation and pumping products with high gas contents generally increases the sound level.

Under the following pumping conditions :

- excluding cavitation
- max. differential pressure :
 - SLC 116 bar (232.11 psi)
 - SLC 210 bar (145 psi)
 - SLC 36 bar (87 psi)
- speed of rotation 1000 rpm
- water product or equivalent

The sound level reached for a SLC pump in good working condition without the drive is lower than 75 dB(A).

3.2 COMMISSIONING

Make sure that the circuit valves are open before starting the pump.

To avoid any risk of polluting the pumped product, rinse the whole installation before starting-up so as to eliminate any contaminants that may remain in the piping, tanks etc. at the time of assembly.

3.3 DRY RUNNING

The SLC pump is self priming and is able to empty the pipes. To do this, it can run dry for a maximum duration of 5 minutes.

For ATEX, see technical instructions 1071.

3.4 STOPPING THE PUMP

So as not to damage the pump, make sure that the pump is completely stopped before closing the valves.

3.5 BELLOWS MONITORING

Failure of the bellows manifests itself as a liquid leakage at the vent (see overall dimensions drawing), when the suction is in positive pressure (> P atmospheric). The vent must remain in the open air at atmospheric pressure (life time of the bellows will be reduced if the vent is closed).

If the pump is equipped with a bellows monitoring system, a failure leads to detection of a pressure drop (pressure gauge or pressure switch). See corresponding §.

4. CLEAN IN PLACE (CIP) & STERILISATION IN PLACE (SIP)

4.1 GENERAL

On-site cleaning (CIP) of an installation is undertaken by circulating various cleaning solutions through the equipment parts.

An automated CIP system enables :

- Preparation of the appropriate concentrations for the different cleaning solutions.
- Re-Heating of certain cleaning solutions at the optimum temperature.
- Circulation of the different solutions through the equipment parts to be cleaned.
- Cleaning and drying of the equipment parts.

For the most part, automated CIP systems are an integral part of process equipments.

Before starting CIP and if the process has not been followed by a water flush, care must be taken that a minimum of residual products remains in the piping and in the pump. The SLC pumps, thanks to their excellent suction and compression capabilities, enable the quantities of residual products to be reduced. This minimises loss of products, eases cleaning and reduces cycle times.

The SLC pumps are perfectly adapted to all processes using CIP. SLC pump has been successfully tested for in place cleanability according to EHEDG document n°2. By complying with the installation rules described above, these pumps will give you complete satisfaction over a long period of time.

The start of CIP must immediately follow the end of the process to avoid any clogging or untimely drying.



UNDER NO CIRCUMSTANCES, SHOULD SLC EXCENTRIC DISC PUMPS BE USED AS CIP PUMPS.

Non-compliance with these instructions will lead to rapid deterioration of the cylinder/piston pair.

4.2 CIP CIRCUIT RECOMMENDED

In all cases, the pressure at the pump inlet during cleaning **must not exceed 3 bar** (43.5 psi).

The flow through the pump required for optimal cleaning is **10 m³/h**.

This flow corresponds to difficult cleaning (sticky and viscous products). It can be reduced for easier types of cleaning.

4.3 PUMPS ARRANGED IN SERIES

This type of assembly is preferred in all cases. It ensures optimal cleaning for the pump and makes use of the special design of the SLC, i.e. the possibility of lifting the piston with the cleaning product.

As the pressure at the pump inlet is higher than that at its outlet, the piston lifts from the cylinder and permits the passage of all the cleaning liquid through the SLC pump.

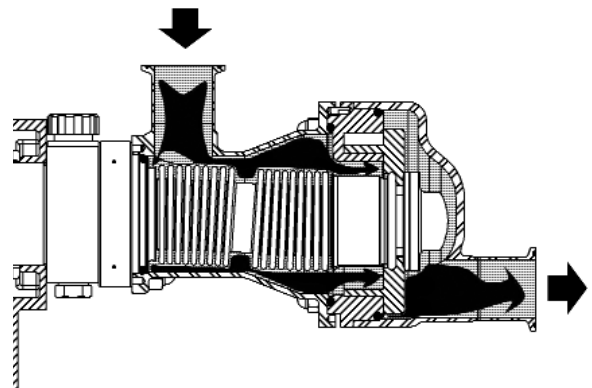

- A centrifuge pump is used for CIP cycles. This centrifugal pump is placed upstream of the SLC pump.

The centrifuge pump must be installed in line with the SLC pump.

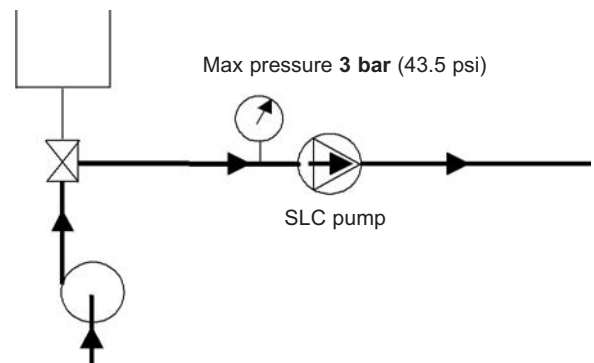

It is preferable not to run the SLC pump during CIP although low speed (< 100 rpm) is acceptable by alternating start/stop operation.

- In certain cases, the flow of cleaning liquid required for the installation is higher than that recommended for cleaning the pump. In this case, a bypass must be used.

The bypass valve is adjusted to divide the flow between the circuit flowing through the SLC pump and the bypass circuit.

4. CLEAN IN PLACE (CIP) & STERILISATION IN PLACE (SIP) (continued)

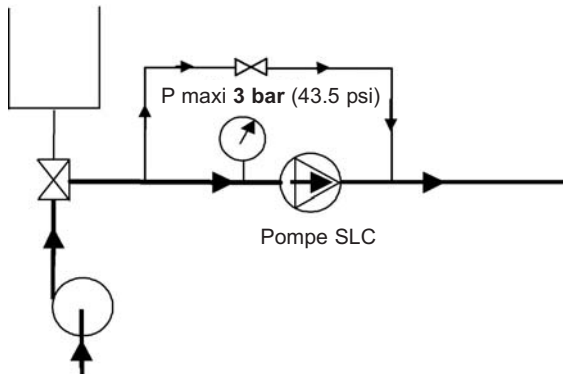

It is preferable not to run the SLC pump during CIP although low speed (< 100 rpm) is acceptable by alternating start/stop operation.

- In certain cases, the cleaning pressure required for the installation is higher than 3 bar (43.5 psi). In this case, the use of a bypass is required and cleaning is done in 2 steps.

Cleaning the pump :

The cleaning flow should be limited during the cleaning of the C pump to ensure a maximum pressure of 3 bar (43.5 psi) at the C pump inlet.

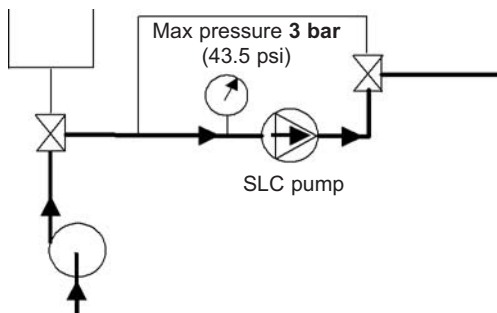

It is preferable not to run the SLC pump during CIP although low speed (< 100 rpm) is acceptable by alternating start/stop operation.

Cleaning the installation :

During this operation, the valve system used must ensure that no flow passes through the pump. This is in order to ensure that the SLC does not run. Under these conditions, with the pump completely stopped, the pressure of the washing circuit can rise up to 6 bar (87 psi).

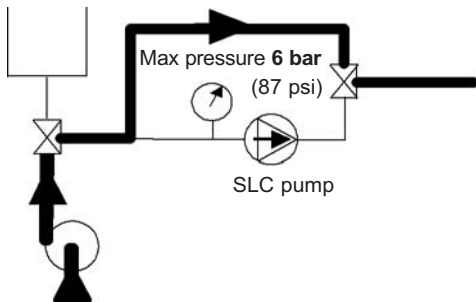

The pump must not run during this operation.

4.4 PUMPS ARRANGED IN PARALLEL

The CIP centrifuge pump must never be installed in parallel with a SLC pump without taking special precautions.

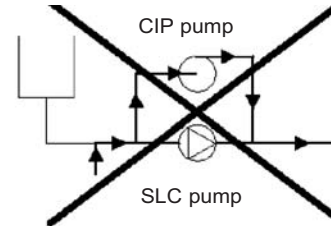

Indeed, in this case, the pressure at the inlet of the SLC pump is lower than the pressure at the discharge and the piston remains forced against the cylinder. Therefore, the SLC pump no longer provides a passage. Its efficient cleaning can no longer be ensured and the cylinder/piston pair will become prematurely worn.

Authorised assembly :

As mentioned previously for applications where cleaning is easy, assembly in parallel is authorised when the valves are installed so that the cleaning pressure of the circuit does not come into contact with the SLC pump.

In this case, the C Series pump cleans itself.

Cleaning the pump :

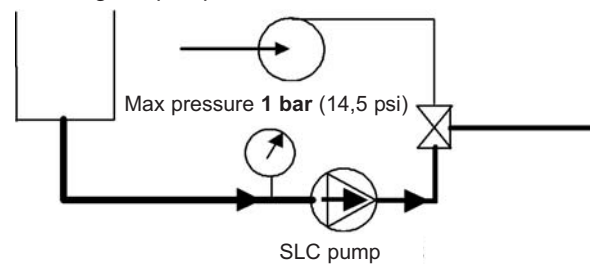

We recommend limiting the rotation speed of the SLC pump.

Cleaning the installation :

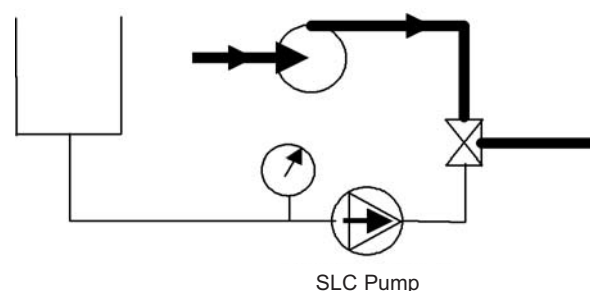

The SLC pump is stopped when cleaning the installation.

4. CLEAN IN PLACE (CIP) & STERILISATION IN PLACE (SIP) (continued)

4.5 SUCCESSIVE CYCLES

Given simply as an example. Must be validated and adapted if necessary, depending on the installation process and the product. Generally, the most efficient CIPs comprise 5 stages :

1. Pre-washing with clean water

Water at room temperature. 10 to 15 minute cycle. This pre-wash enables evacuation of the remaining residues.

2. Washing with an alkaline detergent

Typically this is soda at 2.5% at a temperature of 80°C. 20 to 30 minute cycle. This wash particularly enables dissolving and evacuating grease and proteins.

3. Rinsing with clean water

Water at room temperature. 10 minute cycle. This rinse helps to avoid 2 cleaning solutions being mixed.

4. Washing with an acid solution

Typically this is 2.5% nitric acid at room temperature. 10 to 15 minute cycle. This wash helps to dissolve and evacuate proteins and inorganic salts in particular.

5. Rinsing with clean water

Water at room temperature. Several 1 to 2 minute cycles. These rinses enable all traces of acid solution to be evacuated.

During all these CIP stages, the average speed of the cleaning liquids in the pipes must be between 1,5 and 3 m/s (59 in/sec and 118 in/s).

4.6 STERILISATION IN PLACE (SIP)

The SLC pumps are perfectly adapted to all processes using SIP (Sterilisation In Place) : pump stopped / maximum 20 mn per cycle / 1 or 2 cycles per day.

5. MAINTENANCE

⚠ WARNING

Any unforeseen start-up can cause serious injuries or important material damages.

TAKE ALL NECESSARY MEASURES TO RENDER ANY START-UP, EVEN ACCIDENTAL, OF THE PUMP DURING THE WORK IMPOSSIBLE.

⚠ CAUTION

Hazardous pressure can cause personal injury or property damage.

FAILURE TO RELIEVE THE SYSTEM PRESSURE PRIOR TO PERFORMING ANY WORK ON THE PUMP OR THE INSTALLATION CAN CAUSE PERSONAL INJURY OR PROPERTY DAMAGE.

⚠ WARNING

The weight of the parts can be dangerous and may provoke bodily injuries or material damages.

BE CAREFUL WITH THE WEIGHT OF THE PARTS WHEN THEY ARE BEING REMOVED.

⚠ WARNING

Hazardous pressure can cause personal injury or property damage.

DISCONNECTING THE FLUID OR PRESSURE CONTAINMENT COMPONENTS DURING PUMP OPERATION CAN CAUSE SERIOUS PERSONAL INJURY, DEATH OR MAJOR PROPERTY DAMAGE.

⚠ WARNING

Hazardous or toxic fluids can cause serious injury.

IF PUMPING HAZARDOUS OR TOXIC FLUIDS, THE SYSTEM MUST BE FLUSHED PRIOR TO PERFORMING ANY SERVICE OPERATION.

⚠ CAUTION

Slippery lubricant. Spills should be cleaned up.

THE PUMP LUBRICANT IS VERY SLIPPERY AND MAY CAUSE SERIOUS INJURY. ANY SPILLS MUST BE CLEANED UP.

5.1 NECESSARY TOOLS

- 13, 16, 36 and 94 open-end spanners (or adjustable spanner)
- N° 5 Allen key
- 2 screwdrivers

Tightening torques :

- M6 : 5,5 Nm
- M8 :13 Nm
- M10 :30 Nm
- M30 (piston nut) :40 Nm

5. MAINTENANCE (continued)

5.2 PUMP DISASSEMBLY

Before any dismantling, make sure that the pump has been drained and take the necessary measures to avoid starting-up. No start-up, even accidental, must be allowed.

- Disconnect the pump from the discharge pipe.
- Remove the 4 nuts **106** using the 13 open-end spanner.

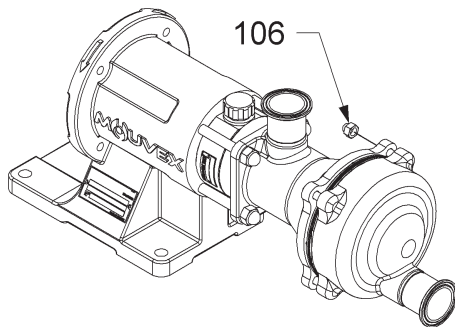

- Lay down the front cover **400** with the 2 screwdrivers.

It is important to keep a good grip on the cylinder as you take the front cover off. Its rotation could lead to deterioration of the bellows.

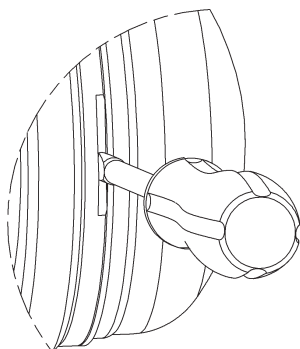
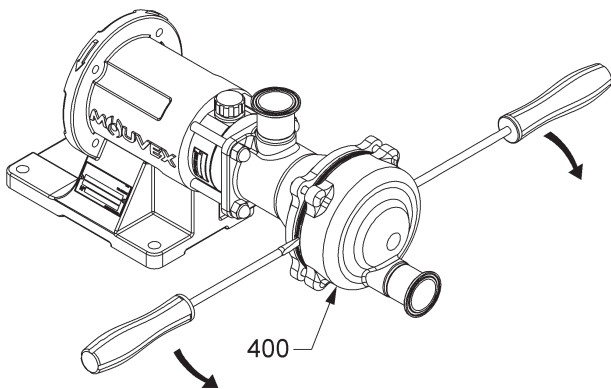

- Remove the seal **205**.

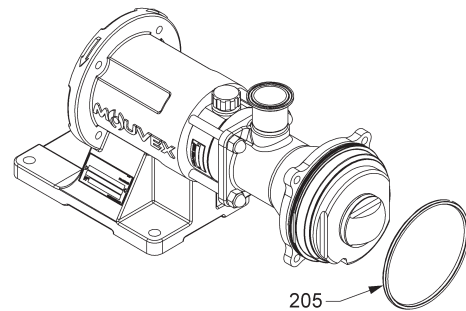

- Hold piston **301** with a 94 open-end spanner or an adjustable spanner and unscrew nut **309** with a 36 open-end spanner.

It is important to keep a good grip on the piston, its rotation could lead to deterioration of the bellows.

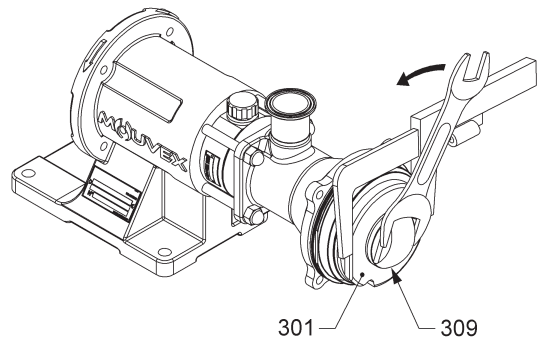

- Extract nut **309** and seal **305**.

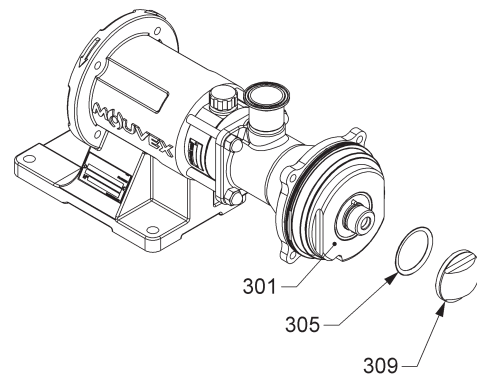

- Extract piston **301** and seal **306**.

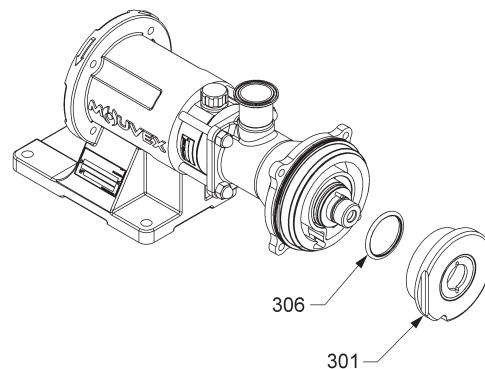

5. MAINTENANCE (continued)

- Remove cylinder **201** and seal **212**.

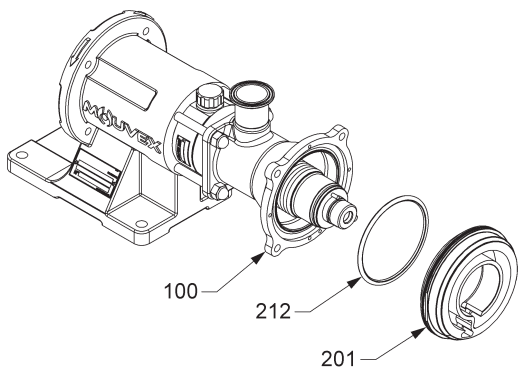

- Unscrew the 4 nuts **115** with a 16 open-end spanner.
- Remove nozzle **100** and seal **113**.

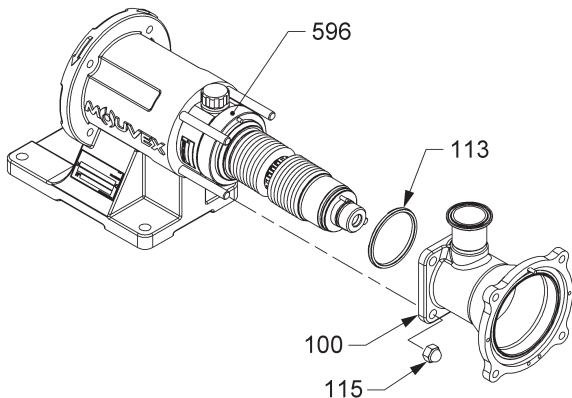

5.3 CHECKING THE CYLINDER/PISTON TORQUE

Piston **301** and cylinder **201** are active parts (wearing parts). These parts must be replaced if the thickness measurements are lower than the following values.

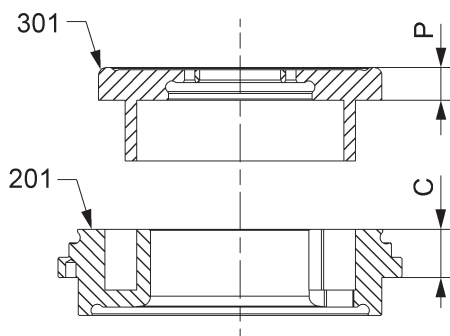

Wear dimensions (mm)				
		SLC 1	SLC 2	SLC 3
Piston 301 (P)	New	12,9	12,9	12,9
	Min	10,9	10,9	10,9
	Standard exchange	12,4	12,4	12,4
Cylinder 201 (C)	New	34	34	34
	Min	32	32	32
	Standard exchange	33,5	33,5	33,5

Wear dimensions (inches)

		SLC 1	SLC 2	SLC 3
Piston 301 (P)	New	0,506	0,506	0,506
	Min	0,427	0,427	0,427
	Standard exchange	0,486	0,486	0,486
Cylinder 201 (C)	New	1,335	1,335	1,335
	Min	1,256	1,256	1,256
	Standard exchange	1,315	1,315	1,315

NOTICE

When disassembling the piston screw **309** if the enclosed thread surfaces have become soiled, we recommend cleaning them as follows : clean the inner thread by washing followed by rinsing with a bactericide solution, then remove any impurities from the external threads by washing with a brush followed by rinsing and sterilizing (i.e. with a steam sterilization) before reassembly.

5.4 REASSEMBLING THE PUMP

- Check the state of seals **113**, **205**, **212**, **305** and **306** and replace them if necessary.

NOTICE

Seals designed for use in normal conditions intended for use in food process. In order to ensure a reliable sealing on SLC pumps we recommend to :

- do an inspection of the seals every three months (this time could be shorter if using the pump in hard conditions. Contact the manufacturer for advice if necessary).
- replace the pump sealing every two years (refer to the § PROTECTION OF THE BELLOWS for the replacement of the second seal).

- Position seal **113** on the large flange.
- Position nozzle **100**, watching out for the indexing pin **513**.
- Position the 4 nuts **115** and screw them in (4 x M10 tightening torque 30 Nm). The nuts will be locked with Loctite® 243 or equivalent thread locking adhesive.

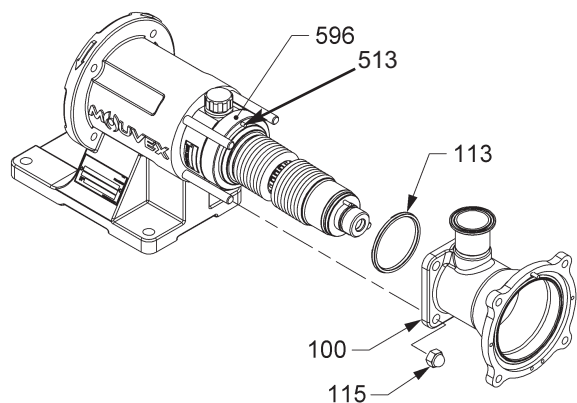

* Loctite® is a registered trade mark.

5. MAINTENANCE (continued)

- Position seal **212** in the cylinder **201**.

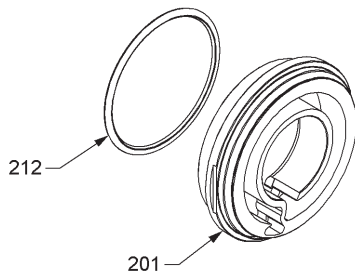

If the 100 nozzle is oriented differently from the standard position (§ 2.1), it is important to orient cylinder 201 as shown here, in other words with the port at the bottom. It is possible to fit the cylinder with the port at the top, but the pump will then not be drainable.

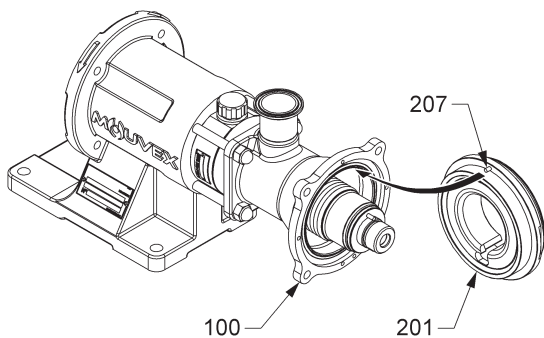

- Position seal **306** in piston **301**.

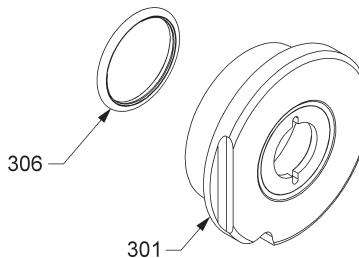

- Insert piston **301** over the transmission hub **596**, with the slot of piston **301** opposite the cylinder partition **201**.

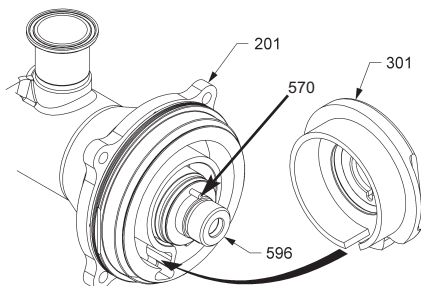

- Exert lateral pressure on the piston to centre it and insert it into the cylinder, then push fully home, taking care to engage the 2 pins **570** on the hub **596** opposite the 2 slots of piston **301**.
- Position seal **305** on nut **309**.
- Hold piston **301** with a 94 open-end spanner or an adjustable spanner and tighten nut **309** with it seal **305**.

It is important to keep a good grip on the piston, its rotation could lead to deterioration of the bellows.

When tightening nut 309, comply with the assembly torque of 40 Nm.

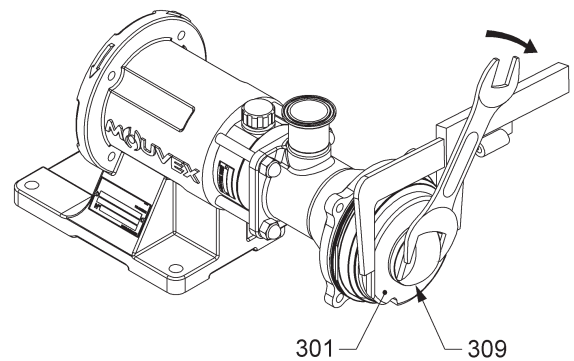
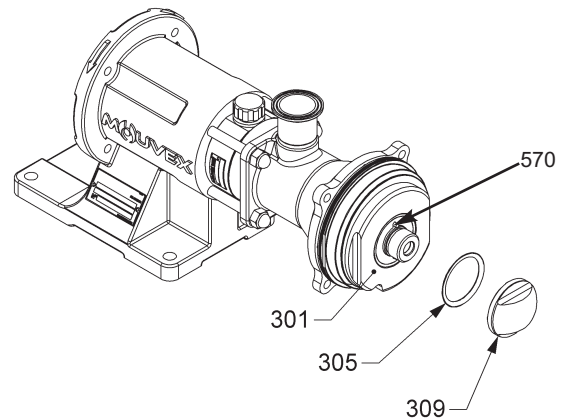

- Position seal **205** on the cylinder

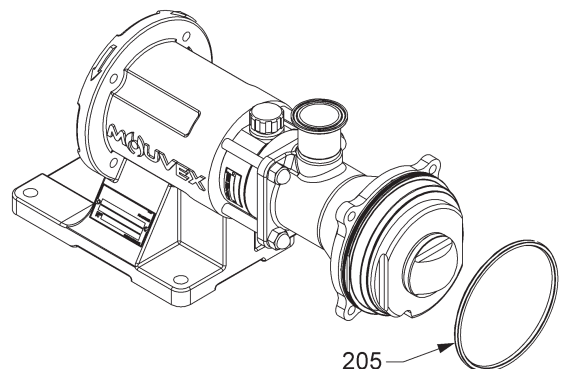

5. MAINTENANCE (continued)

- Re-mount front cover **400** while positioning the outlet port as desired.
- Tighten the 4 nuts **106** with the 13 open-end spanner (tightening torque of the 4 M8 nuts : 13 Nm). The nuts will be locked using Loctite®* 243 or equivalent thread locking adhesive.

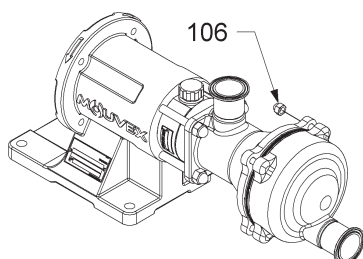

- Then, unscrew the 4 screws **144** using the N° 5 Allen key and uncouple transmission **596** from lantern **780**.

CAUTION :
BE CAREFUL NOT TO KNOCK OR SCRATCH THE BELLOWS.

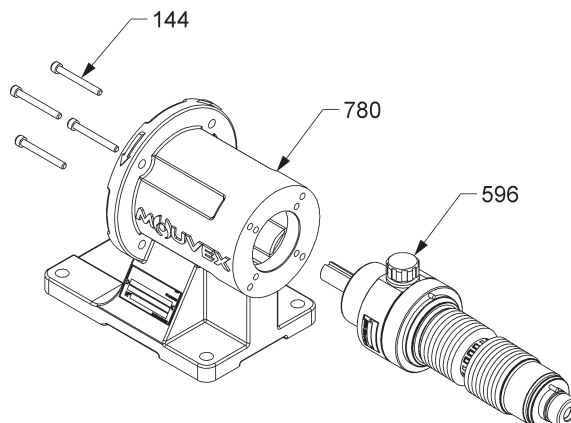

5.5 TRANSMISSION DISASSEMBLY/REASSEMBLY

The transmission is disassembled by removing the front cover and the nozzle as described in the PUMP DISASSEMBLY section.

It is important to note the position of the transmission indexing pin at disassembly.

- Reassembly is in reverse order. The screws **144** must be fitted using Loctite®* 243 or equivalent thread locking adhesive (tightening torque of the 4 M6 screws : 5,5 Nm).

6. CHECKING THE BELLOWS

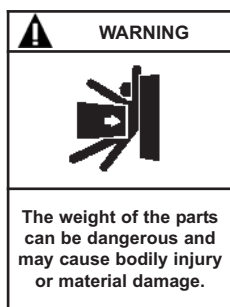

TAKE CARE WHEN REMOVING THE PARTS AS THEY MAY BE HEAVY.

- Disassemble the pump (see corresponding §).
- Inspect the bellows : it must be replaced if there are any traces of impact, scratches or distortion.

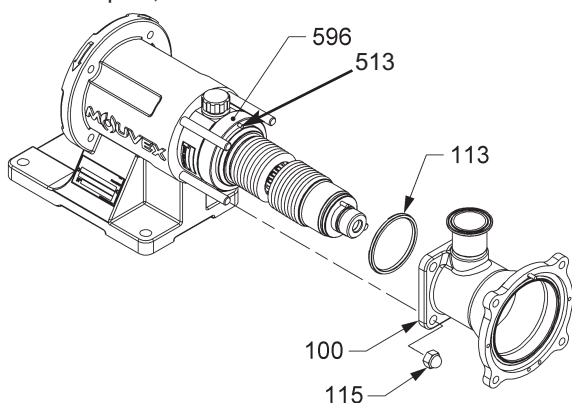

- Reassembly is in reverse order of disassembly, taking care to ensure correct positioning of seal **113** and the indexing pin **513**. The nuts **115** must be fitted using normal thread locking adhesive (Loctite®* 243 or equivalent) : 4 x M10 : tightening torque 30 Nm.

As part of the preventive maintenance programme (every 300 million cycles), a standard exchange of the transmission could be made.

In this case : the transmission delivered is equipped with a foam protective tube. This protection should be left around the bellows until such time as the nozzle is installed.



DO NOT FORGET TO REMOVE THE PROTECTION BEFORE INSTALLING THE CYLINDER.

* Loctite® is a registered trade mark.

7. DRAINING THE BEARING

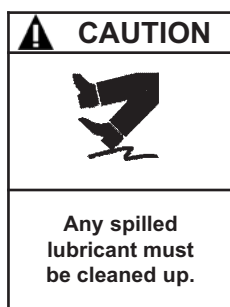

THE PUMP LUBRICANT IS VERY SLIPPERY AND MAY CAUSE SERIOUS INJURY. IT IS ESSENTIAL TO CLEAN UP ANY SPILLS.

- Screw in breather 715.

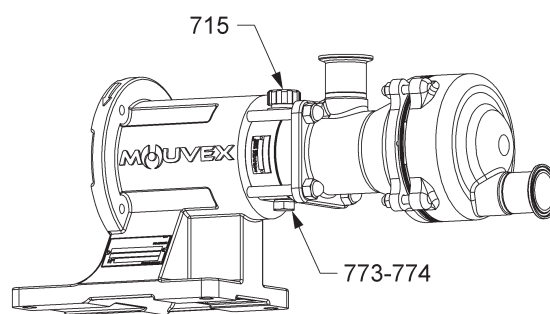

- Drain the transmission as shown in the following table :

- **Data with MOUVEX standard oil :**

Temperature of pumped/ heating fluid	Drain interval (hours of operation)
100 °C < T ≤ 110 °C	6 000
80 °C < T ≤ 100 °C	12 000
T ≤ 80 °C	24 000

- **Data with other customer oil :** The drain interval is defined by the customer (test results) according to the oil specifications and the pump operating conditions.

- Drain the pump by removing the drain plug and its seal **773-774** and the breather **715**.
- Fit the drain plug and its seal.
- Fill the transmission with ≈ 0,22 litres of oil*.
- Check the oil level to make sure that there is 1 to 5 mm above the shaft.

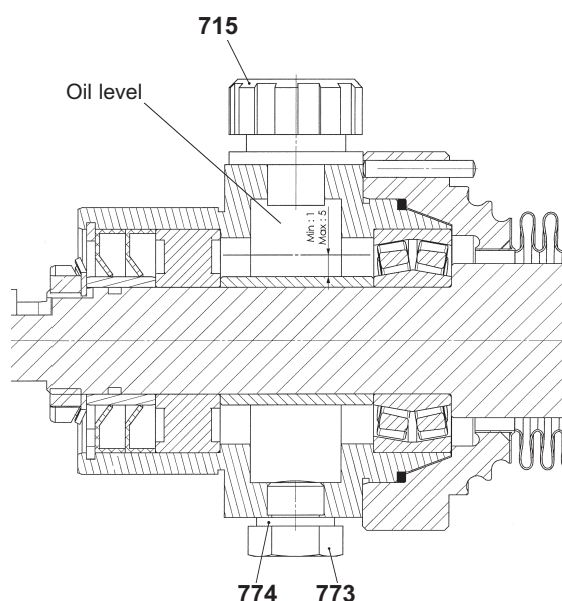

* Standard oil supplied by MOUVEX : CS05 synthetic food grade oil (the safety data sheet is supplied with the new pump and available on request).

* Other oil supplied by the customer.

8. OPTIONS

8.1 BELLOWS MONITORING SYSTEM

Operating principle : when the transmission is installed, a pressurised gas (argon) is introduced between the walls of the bellows. A pressure switch or pressure gauge is connected to the bellows gas filling cavity and the entire circuit is then sealed.

The gas pressure introduced is 0,2 bar higher than the maximum allowable pressure on the bellows in operation.

Any perforation or crack in one of the two bellows leads to a pressure drop. As soon as the pressure drop is sufficient, the pressure switch trips the electrical circuit.

For pressure switch connection, refer to the manufacturer's instructions.