

(See Instructions **1002-B00** for Installation, Operation and Maintenance)

Section	1002
Effective	July 2008
Replaces	August 2005

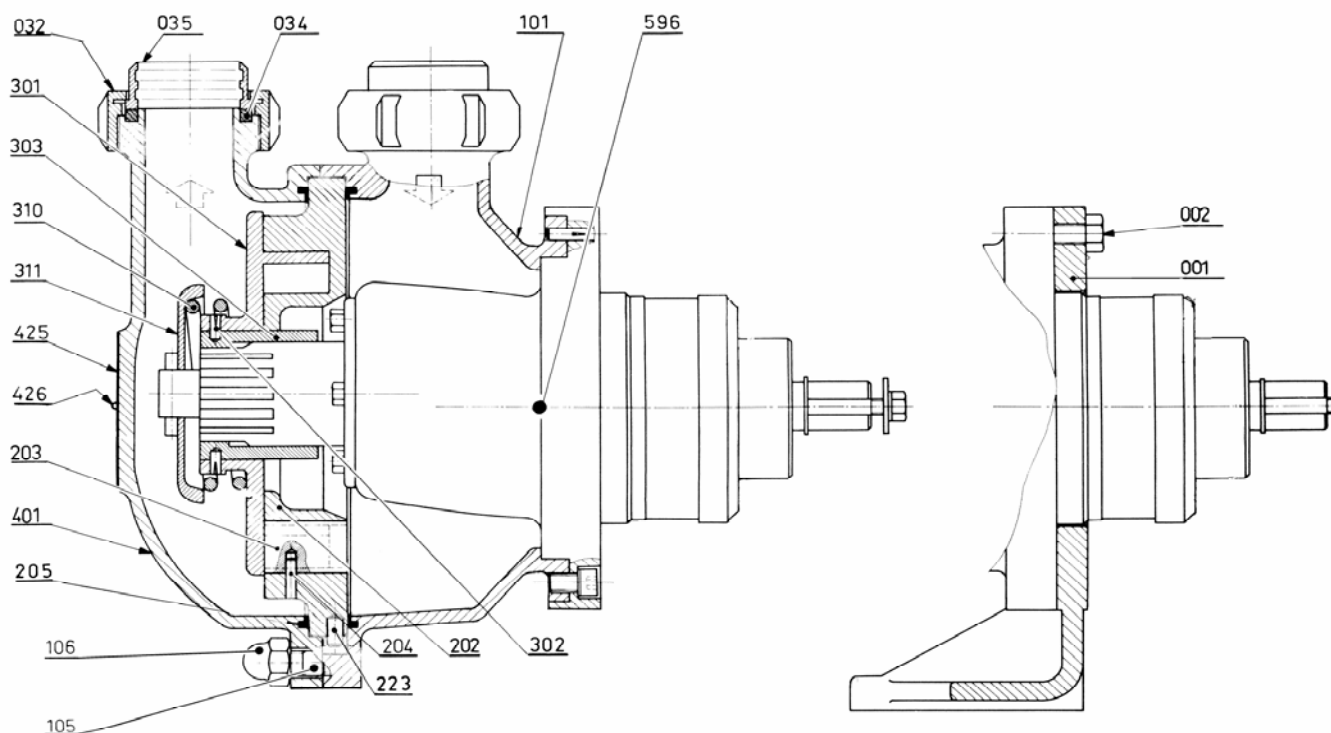

Reference			Description	Quantity		ARTICLE CODE		Wear parts
Ass.	Part	Available		Order	In Pump	S4C AL	S4C CH	
5	001 002	◆	Support foot pump complete Support foot Foot screw	1	(1) (4)	301566.00		
30		◆	Set FKM SMS 51 connections	1		311444.00		
30		◆	Set FKM DIN 50 connections	1		311665.00		
30		◆	Set EPDM SMS 51 connections	1		301545.00		
30		◆	Set EPDM DIN 50 connections	1		304520.00		
	1012 1017 1019		Gasket Locked nut Smooth pipe		(2) (2) (2)			
45		◆	Set smooth pipe FKM 51	1		312696.01		
45		◆	Set smooth pipe EPDM 51	1		301563.00		
	1012 1017 1019		Gasket Locked nut Smooth pipe		(2) (2) (2)			
100		◆	Polish Connection pipe SMS 51	1		308753.00		
100		◆	Polish Connection pipe DIN 50	1		308752.00		
100		◆	Connection pipe SMS 51	1			304653.00	
100		◆	Connection pipe DIN 50	1			311413.00	
	101 105 106		Inlet tube Stud Blind nut		(1) (4) (4)			
110		◆	Set screws	1		304855.00		
	106		Blind nut		(4)			

(◆) Sets of parts or (▲) parts available to order

Keep this parts lists with Installation, Operation and Maintenance Instructions

Reference			Description	Quantity		ARTICLE CODE		Wear parts
Ass.	Part	Available		Order	In Pump	S4C AL	S4C CH	
120		◆	Set gaskets connection FKM SMS 51	1		311445.00		
120		◆	Set gaskets connection FKM DIN 50	1		311653.00		
120		◆	Set gaskets connection EPDM SMS 51	1		304857.00		
120	034	◆	Set gaskets connection EPDM DIN 50	1		304862.00		
			Gasket		(6)			
200		◆	Set Cylinder/Piston	1		313409.00		•
	201		Cylinder		(1)			
	301		Piston		(1)			
310		▲	Spring back piston	1		201217		
310		▲	Strong spring back piston	1		216493		
311		▲	Back piston support	1		203746		
206		◆	FKM Oring	1		304853.00		
206		◆	EPDM Oring	1		304854.00		
	205		O-ring		(2)			
400		◆	Polish bottom SMS 51	1		308757.00		
400		◆	Polish bottom DIN 50	1		308756.00		
400		◆	Bottom SMS 51	1			304654.00	
400		◆	Bottom DIN 50	1			311414.00	
	401		Front cover		(1)			
	425		Name plate		(1)			
	426		Plate rivet		(2)			
596		◆	Complete Transmission block FKM	1		502033.01		•
596		◆	Complete transmission block FKM with detection	1		513912.01		•
596		◆	Complete Transmission block EPDM	1		513918.01		•
596		◆	Complete Transmission block EPDM with detection	1		513913.01		•

(◆) Sets of parts or (▲) parts available to order

Keep this parts lists with Installation, Operation and Maintenance Instructions



Z.I. la Plaine des Isles - 2 rue des Caillottes F-89000 AUXERRE - FRANCE
 Tel : +33 (0)3 86 49 86 30 • Fax : +33 (0)3 86 49 87 17
 contact@mouvex.com - www.mouvex.com