



INSTRUCTIONS 1002-F00 e

Section	1002
Effective	January 2008
Replaces	March 2005

Translation of the original instructions

Transmission safety S serie

INSTALLATION

**BLACKMER
ZI PLAINE DES ISLES
F- 89000 AUXERRE**

Tel. : +33 3.86.49.87.13
Fax : +33 3.86.49.87.17
e-mail : contact@blackmer-mouvex.com

Your distributor :

1. PRESENTATION

It appears thus : Safety sensor **779** (**769** + **773** + **784**) mounted on transmission block **596**.

The detection sensor **779** is fitted as standard to the transmissions of series S pumps.

For use in a non-explosive atmosphere.

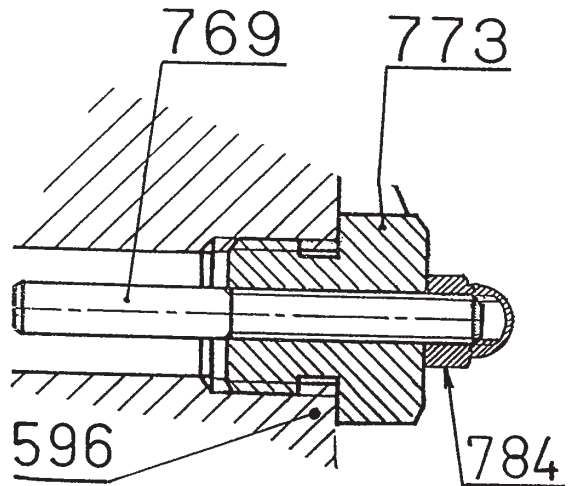

2. CONNECTION OF PLUG-ENDED CABLE TO THE SAFETY SENSOR

Plug-ended cable **780** (**770** + **771** + **775** + **776** + **777** + **778** + **783**) is connected to the safety sensor.

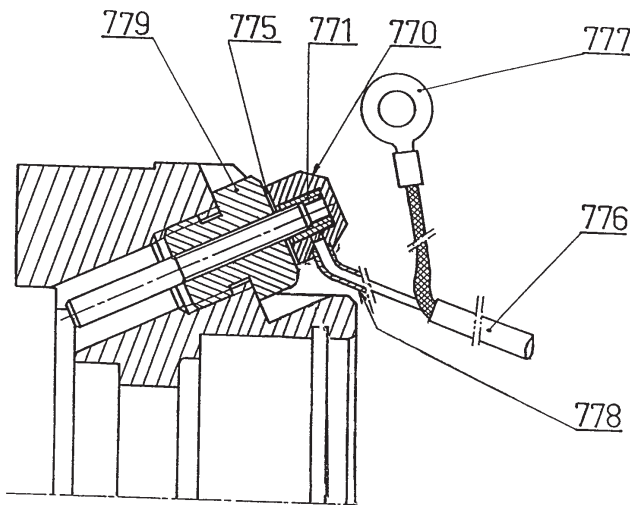

2.1 PUMP S2 OR S6 WITH BRACKET

- Separate the pump from the bracket.
- Remove the protection nut **784**.
- Remove the plug **75** with its seal which, on the bracket, blocks up the aperture through which the user will pass the plug-ended cable **780**.
- Pass this cable through the gland **783** and fit it to the pump bracket .
- Tighten the gland taking care not to strain the leads connected to the pump nor to make them too much slack.
- Fix the pump to the pump bracket.

2.2 IN ALL S2 - S4 AND S6 PUMPS

- Fit the seal **775** to the safety sensor, then screw on the plastic nut **770** without forcing and locking it.
- While tightening the plastic nut, be careful not to damage the cable leaving the nut.
- The earthing is achieved by the terminal **777** crimped to one of the conductors of cable **776** which the user must connect to one of the pump screws **723**.

3. CONNECTION OF THE S2 - S4 - S6 PUMP-MOUNTED CABLE

The cable connected to the safety sensor will be connected to the sealed branch box in which the user will connect his connecting cable to the relay.

4. CONNECTION OF TRANSMISSION SAFETY SYSTEM WITH BRACKET

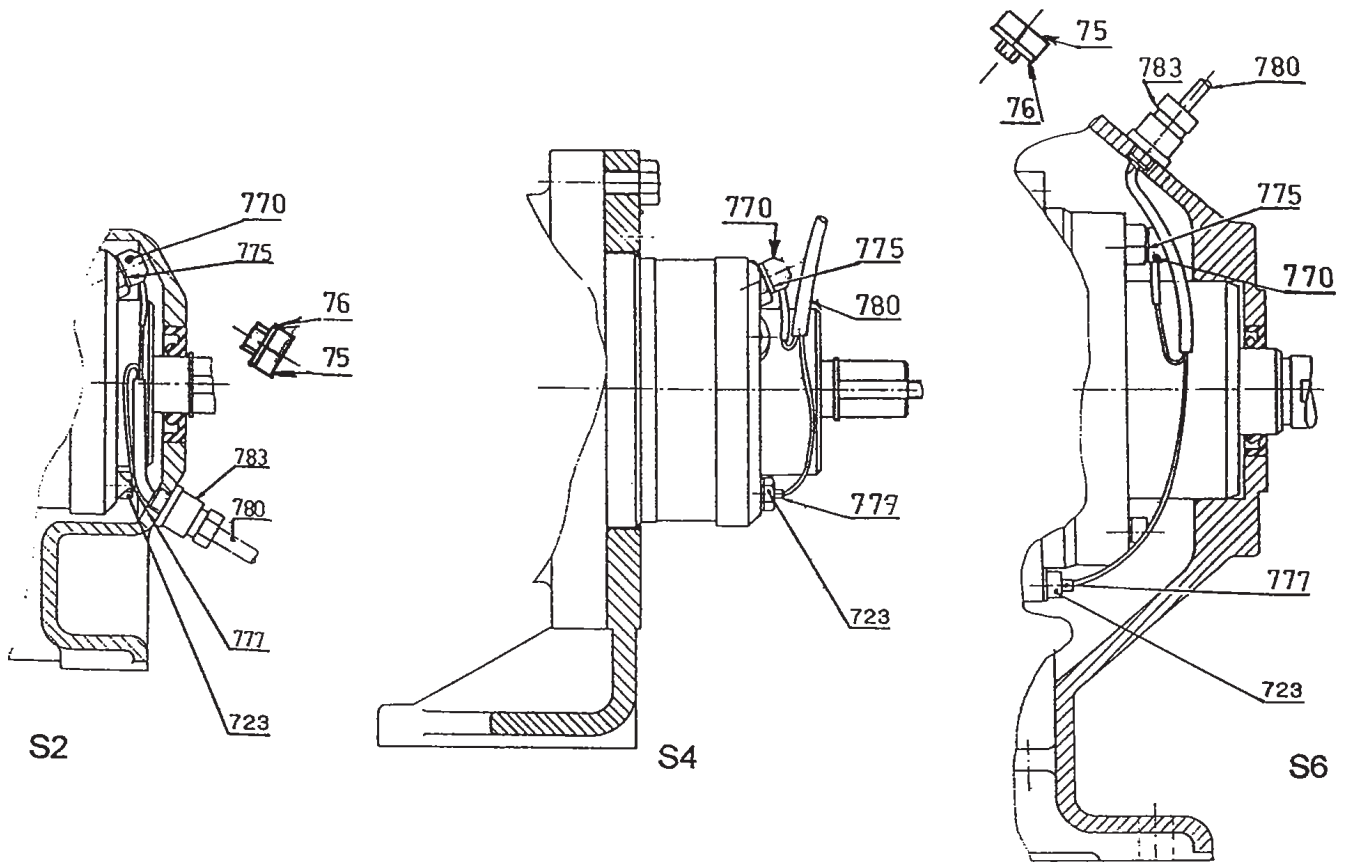

5. S2 - S4 - S6 ELECTRICAL CONNECTION

5.1 NON EXPLOSIVE AREA

The connection of the relay only and the connection of the relay to the circuit-breaker of the electric motor are made as shown in the diagram below.

The relay must be installed in a dry and non-explosive area.

In normal operation of the detector, the relay F1 is closed, S1 opened.

In fault situation, F1 open, S1 closed.

RELAY WITH CIRCUIT-BREAKER

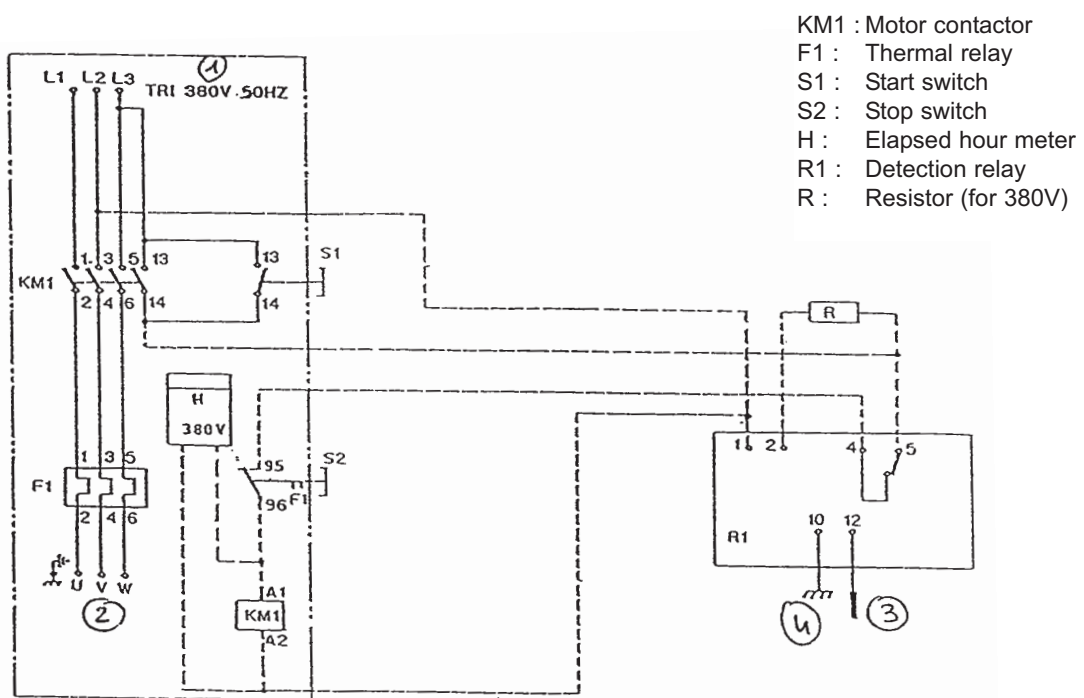

RELAY ONLY

4 and 5 closed = NORMAL

6 and 5 closed = FAULT

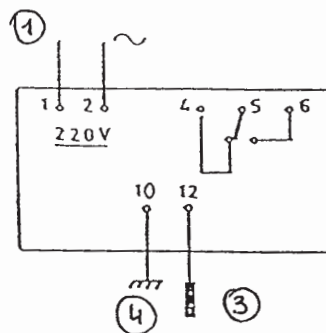

- 1 : Power supply
- 2 : Utilisation
- 3 : Detector sensor
- 4 : Earthing of pump

5.2 DISCONNECTION OF THE PLUG-ENDED CABLE

Disconnect the power supply from the relay, terminals 1 and 2, and disconnect the lead which connects the relay to the branch box. Then carry out the connection operations in the reverse order.