



INSTRUCTIONS 1008-J00 e

Section	1008
Effective	April 2008
Replaces	June 2007

Original instructions

Electric reheating ***P BA Serie***

Complement in the 1008-C00 instructions



INSTALLATION

OPERATION

MAINTENANCE



This BLACKMER Instructions provides assistance for installation but it is not, in any circumstances, intended to replace the specific Instructions of the relevant equipment suppliers.

Those Instructions must be read before fitting the equipment.

BLACKMER
Z.I. Plaine des Isles
F- 89000 AUXERRE
Tel. : +33 3.86.49.87.16
Fax : +33 3.86.49.87.17
E-mail : contact@blackmer-mouvex.com

BLACKMER
1809 Century Avenue, Grand Rapids
MICHIGAN 49509-1595 - U.S.A.
Tél. : +1 (616) 241-1611 Fax : +1 (616) 241-3752
E-mail : blackmer@blackmer.com
Internet Address: www.blackmer.com

Your distributor :

1. OVERALL DIMENSIONS

P40 BA

Electric reheating

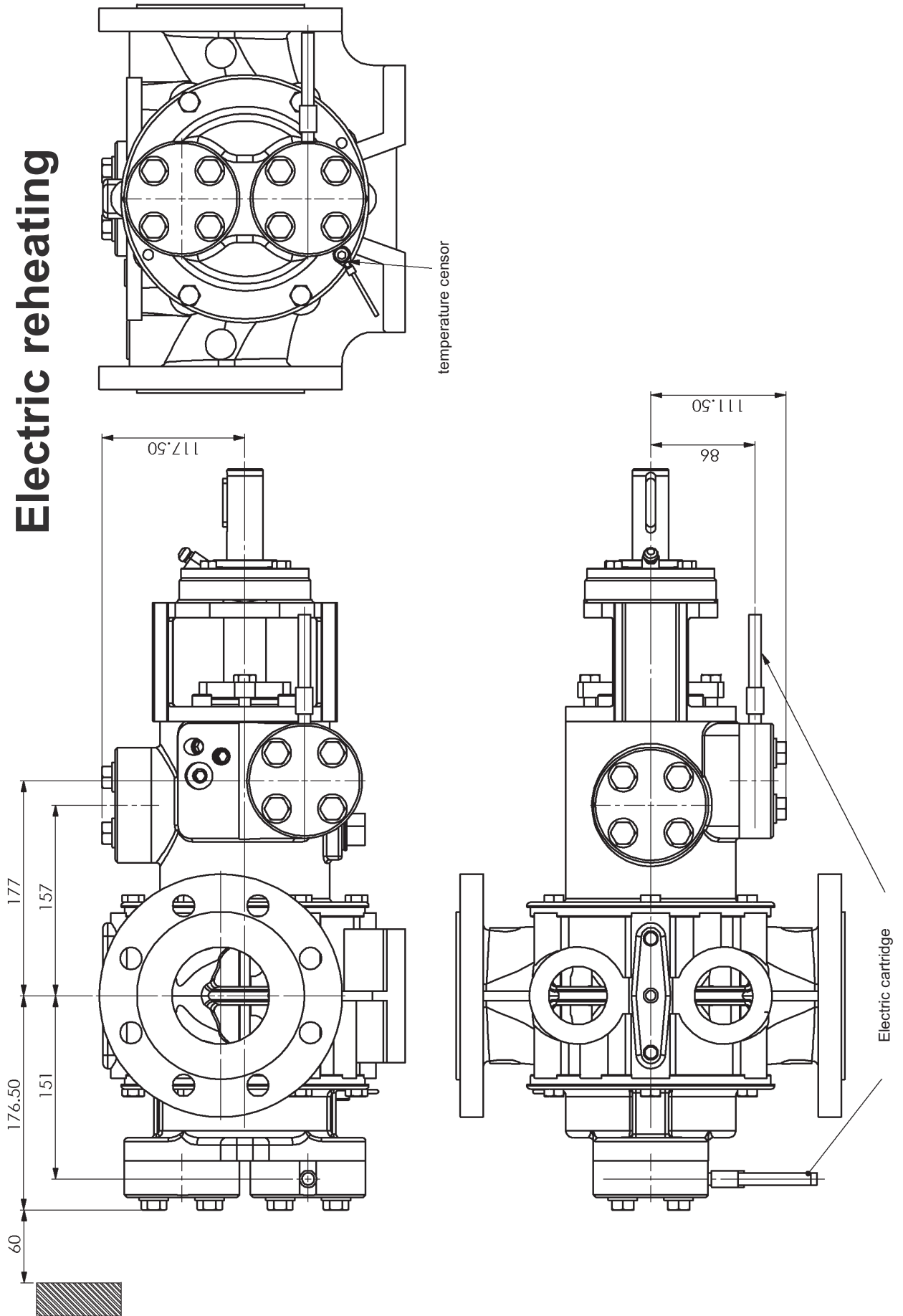

1. OVERALL DIMENSIONS (continued)

P60 BA

Electric reheating

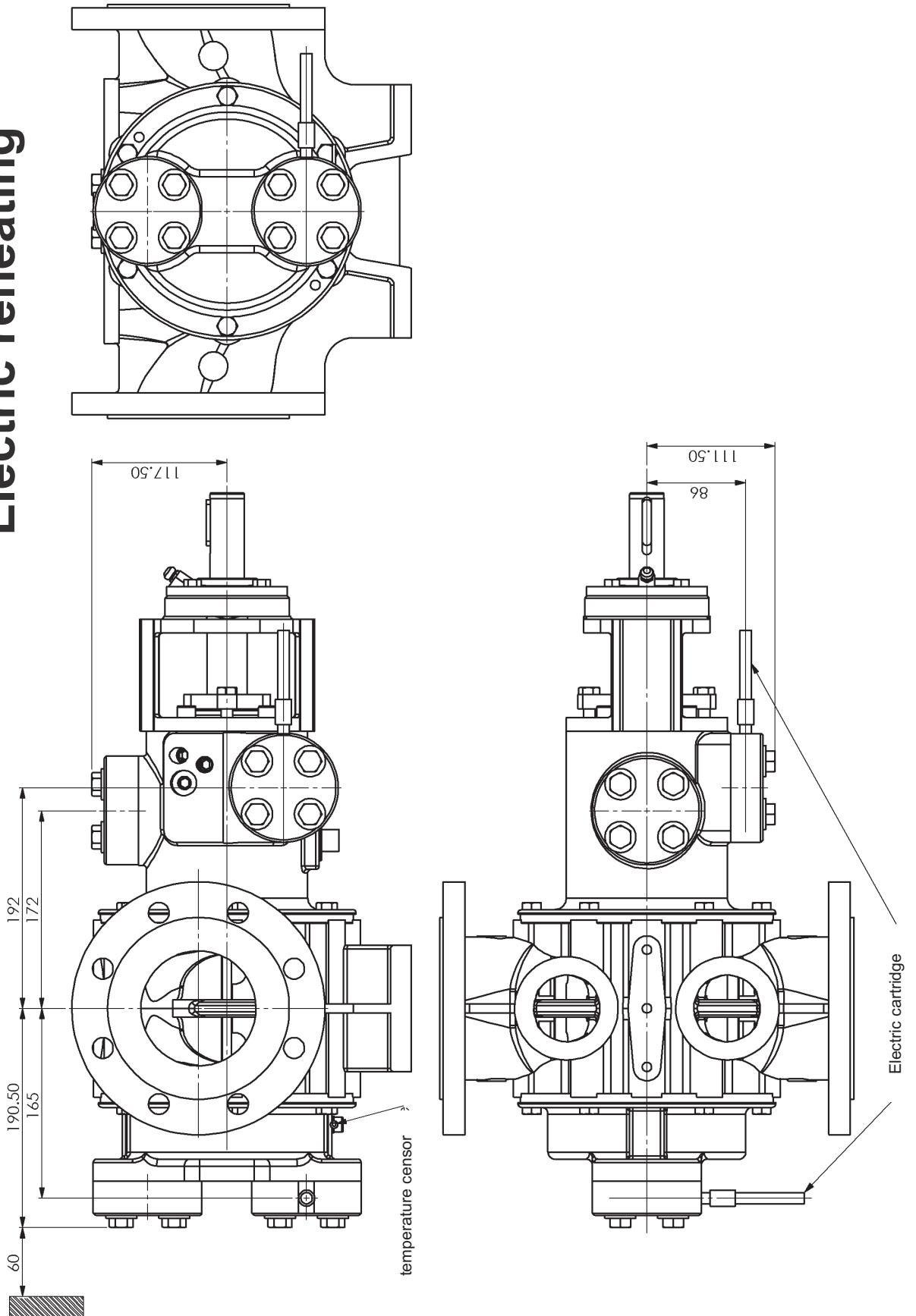

1. OVERALL DIMENSIONS (continued)

P100 BA

Electric reheating

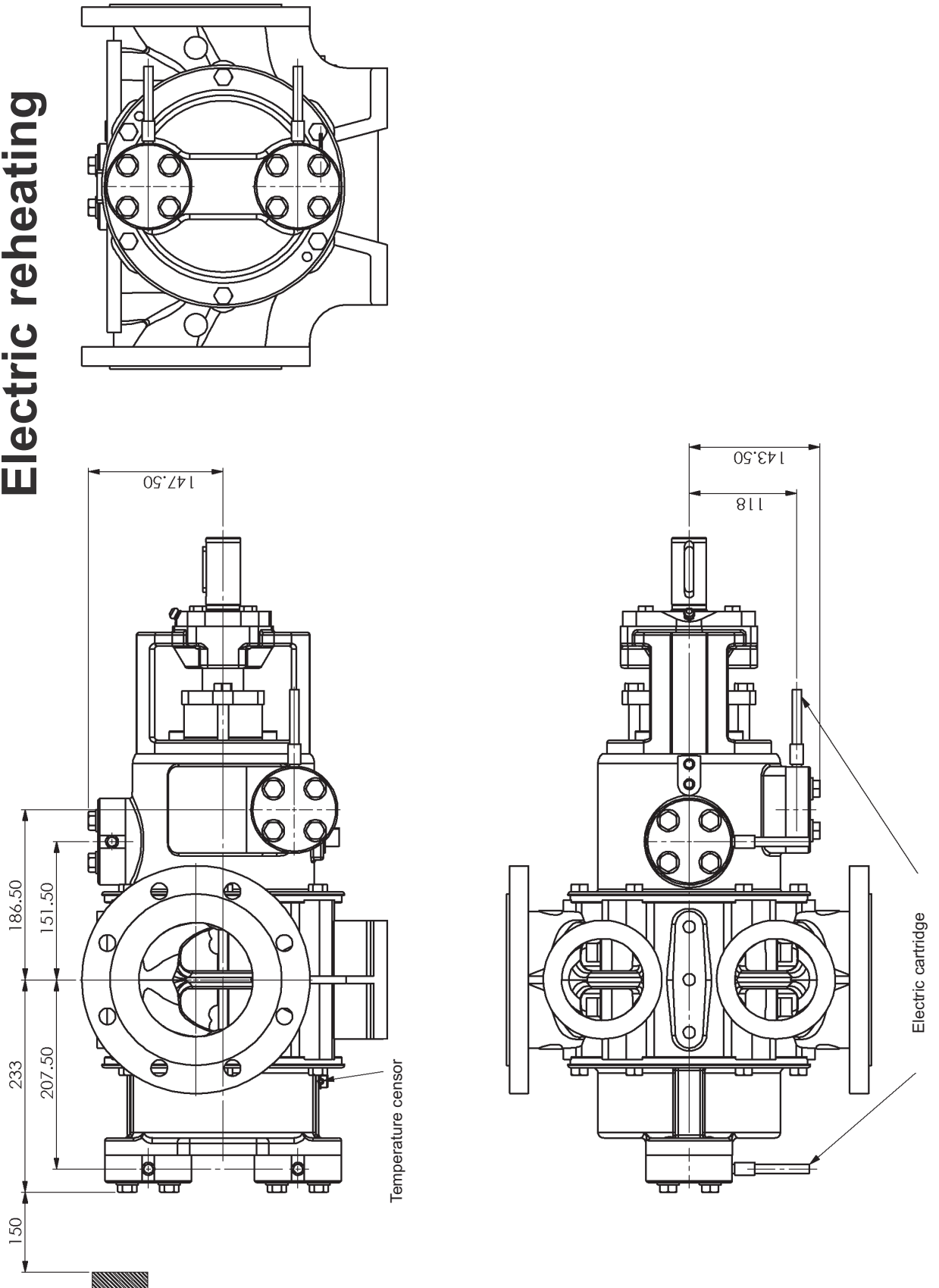

2. OVERALL DIMENSIONS - ASSEMBLIES

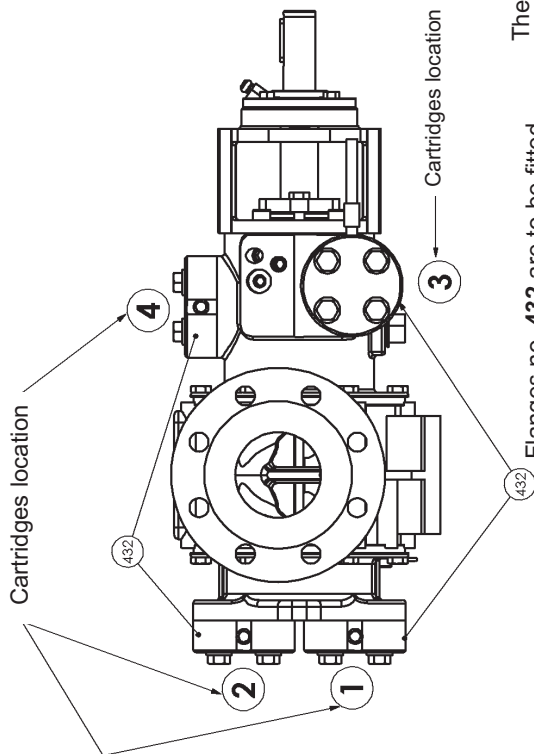

Flanges no. 432 are to be fitted using thermal paste.

The censor no. 434 shall be fitted using thermal paste.
The bottom surface in contact with the censor shall be lined.

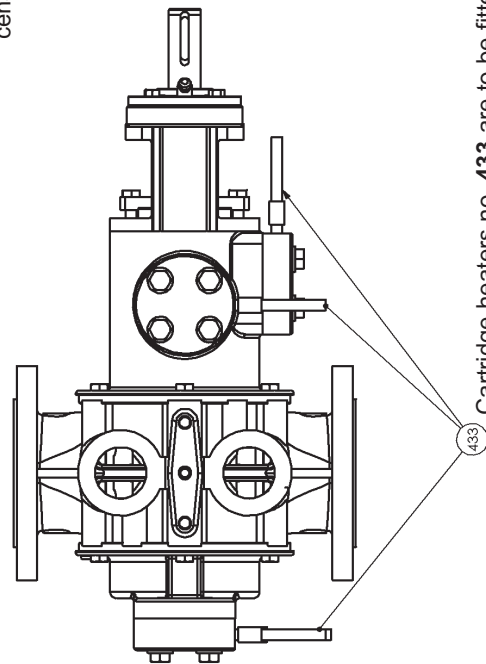
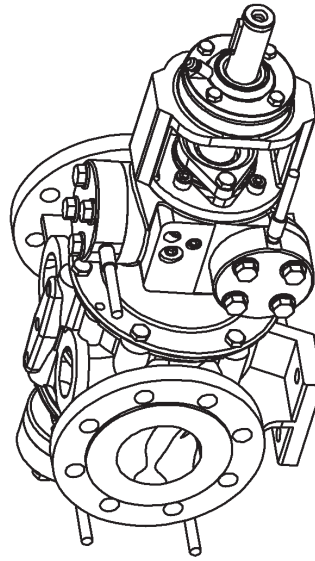
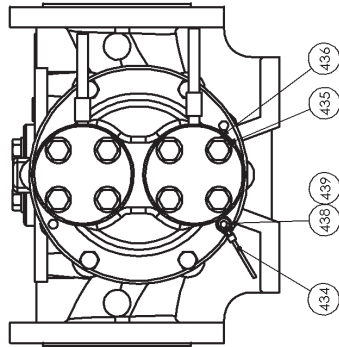

Cartridges location	Emulsion			Bitumen		
	P40 BA	P60 BA	P100 BA	P40 BA	P60 BA	P100 BA
1	300 W	400 W	500 W	500 W	500 W	500 W
2	-	-	500 W	500 W	500 W	500 W
3	300 W	400 W	500 W	500 W	500 W	500 W
4	-	-	500 W	-	500 W	500 W

2. OVERALL DIMENSIONS - ASSEMBLIES (continued)

The heating flanges, heating elements and the temperature sensor shall be fitted using heat-conducting paste to ensure good heat dissipation.

In any event, the pump shall be correctly lagged $R \Rightarrow 2.5$ ($m^2.K/W$) so as to dissipate as little energy as possible. We recommend to program the digital regulator on "hit or miss" mode with an hysteresis of $\pm 5\%$ to extend the life cycle of the contactor (limited number of cycles).

2.1 P40



Electric heating for applying bituminous emulsion:

- See drawing above for location and power of the electric cartridges.
- Power supply voltage 230 V.
- Heating speed (lagged pump): 50°C in 1 h 20 mins.
- CAUTION : The regulator instruction shall not exceed 70°C so that the pumped product is not damaged.
- The emulsion shall not exceed 95°C on pain of being broken (separation of water and bitumen).

Electric reheating for bitumen application :

- See drawing above for location and power of the electric cartridges.
- Power supply voltage 230 V.
- Heating speed (lagged pump): 130°C in 2 h.
- CAUTION : The regulator instruction shall not exceed 160°C.

2.2 P60



Electric reheating for application émulsion de bitume :

- See drawing above for location and power of the electric cartridges.
- Power supply voltage 230 V.
- Heating speed (lagged pump) :
 - * Product temperature : 50°C in 3 h.
- CAUTION : The regulator instruction shall not exceed 75°C so that the pumped product is not damaged.
- The emulsion shall not exceed 95°C on pain of being broken (separation of water and bitumen).

Electric reheating for bitumen application :

- See drawing above for location and power of the electric cartridges.
- Power supply voltage 230 V.
- Heating speed (lagged pump) : 130°C in 2 h 30 mins.
- CAUTION : The regulator instruction shall not exceed 160°C.

2.3 P100



Electric reheating for application émulsion de bitume :

- See drawing above for location and power of the electric cartridges.
- Power supply voltage 230 V.
- Heating speed (lagged pump) : 50°C in 2 h.
- CAUTION : The regulator instruction shall not exceed 70°C so that the pumped product is not damaged.

This is to avoid having a significant hot spot that could damage the pumped product.

- The emulsion shall not exceed 95°C on pain of being broken (separation of water and bitumen).

Electric reheating pour application bitume :

- See drawing above for location and power of the electric cartridges.
- Power supply voltage 230 V.
- Heating speed (lagged pump) : 130°C in 2 h 45 mins.
- CAUTION : The regulator instruction shall not exceed 175°C so that the pumped product is not damaged.

3. AVAILABLES KITS

Several kits are available in accordance with customers' requirements :

- Flange + cartridge kit including 4 x heating flanges, electric cartridges and necessary screws.
- Emulsion or bitumen kit including the flange + cartridge kit and electrical instruments used for controlling the eating.

- Regulator + contactor kit
- Electric connection kit including the connection box and the connection equipment

	Flange emulsion kit + cartridge	Flange bitumen kit + cartridge	Emulsion kit (with regulation)	Bitumen kit (with regulation)	Regulator + contactor kit	Connecting box kit
P40 BA	313665.00	313709.00	313655.00	313710.00	314148.00	314156.00
P60 BA	313666.00	313707.00	313653.00	313708.00		
P100 BA	313667.00	313667.00	313656.00	313656.00		

4. THE EQUIPMENT SUPPLIED (in accordance with the kit selected)

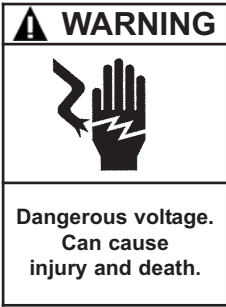

DISCONNECT THE ELECTRICITY SUPPLY
BEFORE ANY MAINTENANCE OPERATION.

4.1 Proportional regulator



To be programmed preferably in digital mode.

4.2 Electric cartridge



The cartridges are fitted by sliding them into the heating flanges. Heat-conducting paste shall be applied to the cartridge at the time of assembly in order to improve thermal conductivity between the flange and the cartridge. The excess of paste must be evacuated through the breather hole opposite the bore to ensure that it is not clogged. This will prevent an accumulation of humidity.

4.3 The temperature censor



The temperature censor is secured to the bottom opposite the pump drive system.

4.4 Contactor

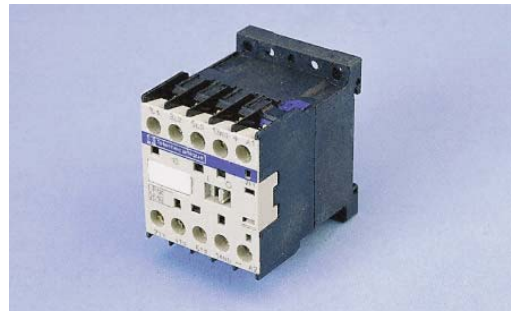

4.5 Connecting box



5. WIRING OF ELECTRIC EQUIPMENT

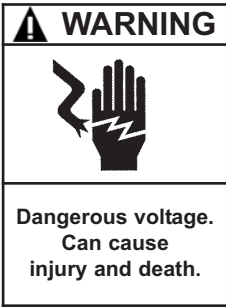

DISCONNECT THE ELECTRICITY SUPPLY
BEFORE ANY MAINTENANCE OPERATION.

The connection of the electrical equipment must be realized in accordance with good trade practices and by means of the user manuals of the supplied components.

Depending on the equipment installation area and the degree of protection to be given, the regulator and the contact switch shall be installed inside a box or a suitable cabinet with the same degree of protection.

It is important to understand that it is the responsibility of the installer to ensure the compliance with the regulations on safety requirements and EMC.

5.1 Wiring of the electric heating kit connecting box

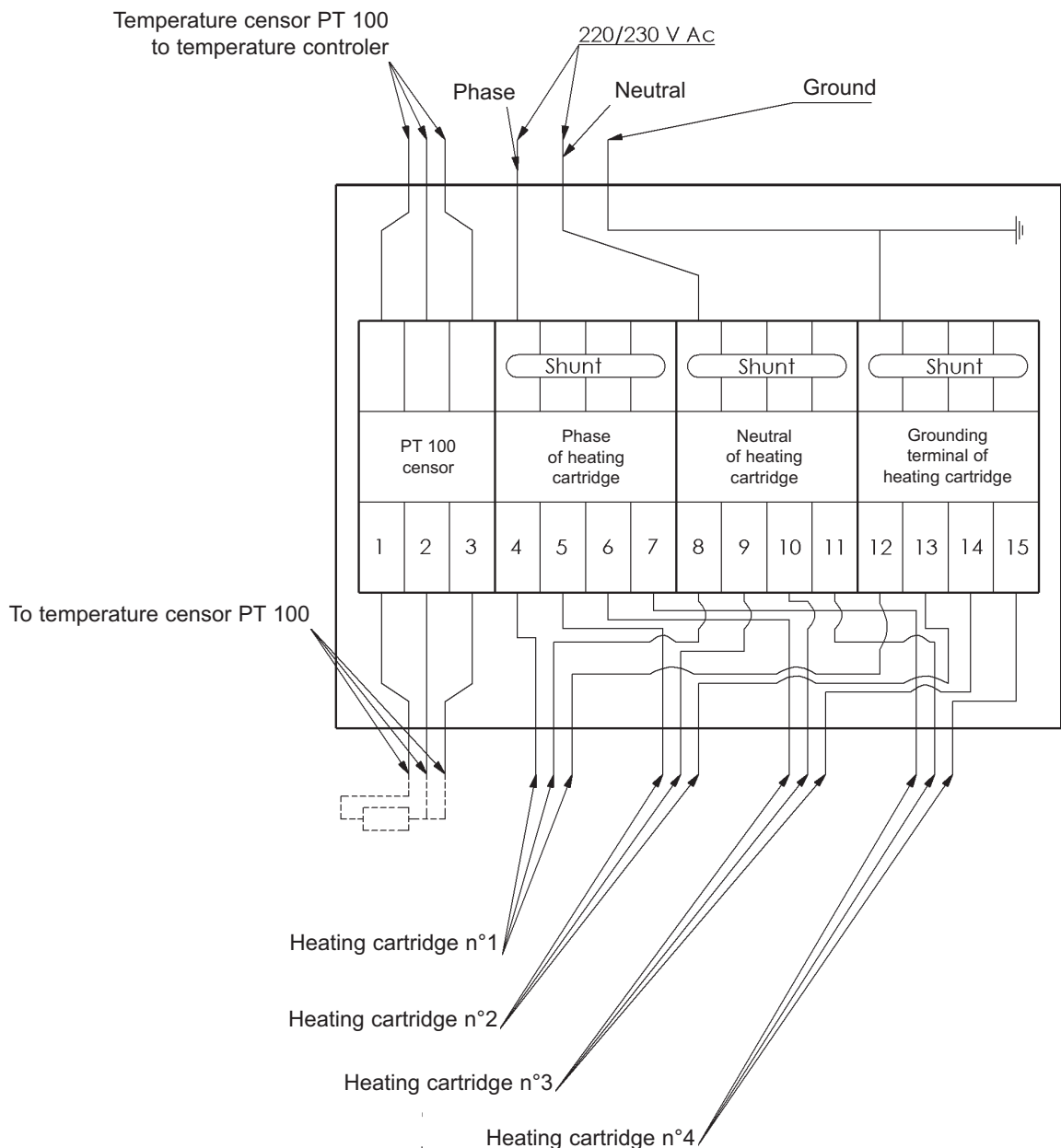

5. WIRING OF ELECTRIC EQUIPMENT (continued)

5.2 Wiring diagram - Electric reheating

