



INSTRUCTIONS 1010-F00 e

Section	1010
Effective	November 2004
Replaces	307

Translation of the
original instructions

CC8-40V - CC8-65V

pumps

INSTALLATION

OPERATION

MAINTENANCE

**BLACKMER
ZI PLAINE DES ISLES
F- 89000 AUXERRE**

Tel. : +33 3.86.49.87.16
Fax : +33 3.86.49.87.17
e-mail : contact@blackmer-mouvex.com

Your distributor :

OVERALL DIMENSIONS - MM

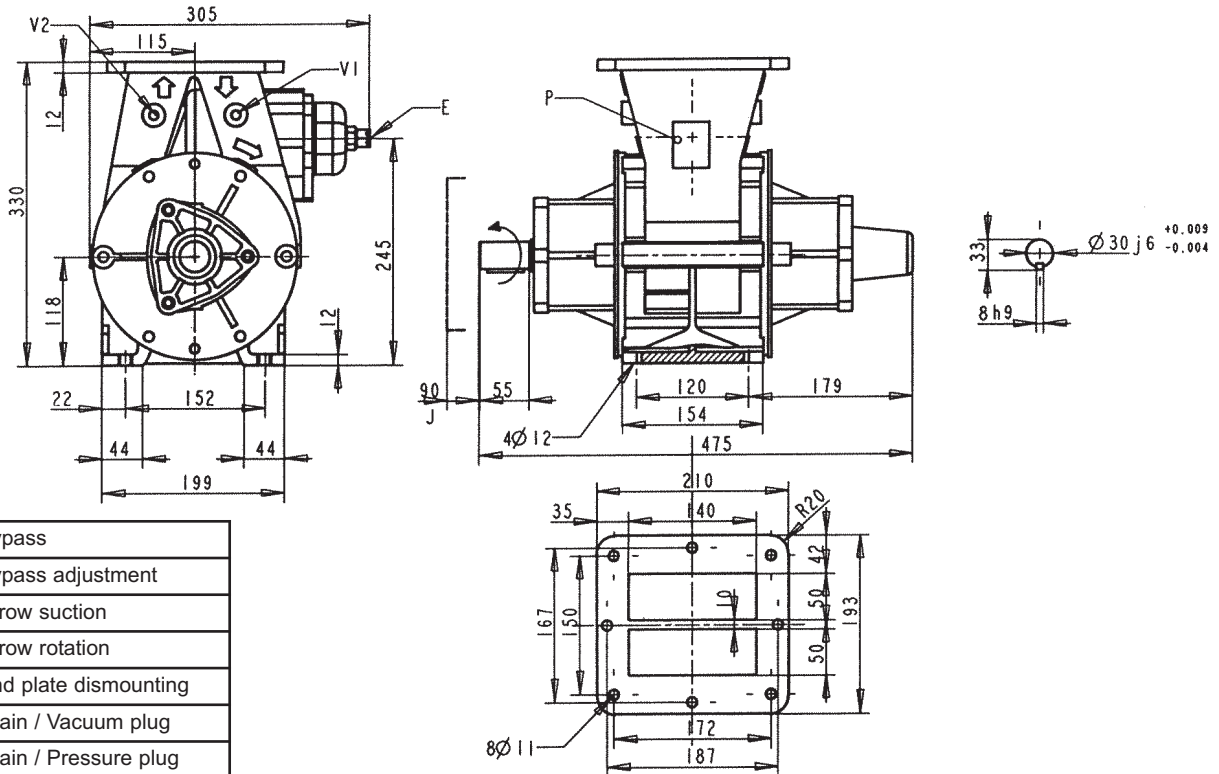

B	Bypass
E	Bypass adjustment
O	Arrow suction
F	Arrow rotation
J	End plate dismounting
V1	Drain / Vacuum plug
V2	Drain / Pressure plug
P	Pump plate

The pump rotates in one direction only. However, the pump has both of its shaft-ends led out and must be driven through one or dht other depending on the direction of rotation of the power off.

In the 2 cases, the position of the suction and discharge ports and of the safety bypass cannot be reversed.

TECHNICAL DATA

Product pumped	Speed range (rpm)	Maximum flow (m³/h)		Maximum pressure (bar)	Required power at max.pressure -Kw	
		CC8-40 V	CC8-65 V		CC8-40 V	CC8-65 V
Construction A Viscosity < 40 cSt	500 à 750	30	43	8	8,7	12,5
	500 à 1200	50	73	4	8,4	12,2

The pumps CC8-40 V and CC8-65 V can work at a pressure equal to 8 bar. They are normally delivered with spring adjusted at 4 bar. When requested, they can be delivered with a 8 bar spring.

DISMANTLING - REASSEMBLY

Before any disassembly, make sure that the pump has been drained and must not start up, even accidentally.

NECESSARY TOOLS

- Flat wrenches 13, 17, 22
- Tube wrench 17
- Circlip opening pliers
- Screwdriver
- Mallet

DISMANTLING PUMP ON SIDE OPPOSITE TO DRIVE SYSTEM

Unscrew the screws **723** and remove the cover **712**.

Remove circlip **537**.

Carefully clean the shaft end (remove any trace of paint, oxidation, burrs...).

Unscrew the 4 screws **410**.

Unscrew the 2 screws **411** fitted with their nut **412** and place them in the 2 tapped holes T.

Screw up the 2 screws at the same time so that the end-plate is gradually released along the centre line.

When the end-plate is free on the shaft, hold it by hand supporting it.

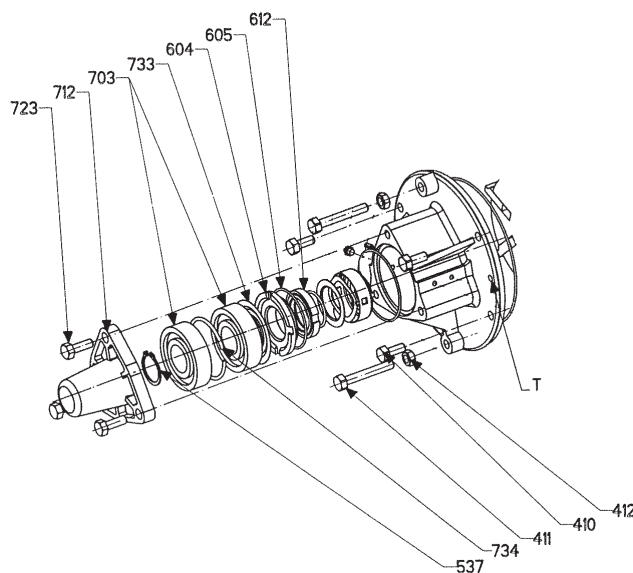

DISMANTLING PUMP ON DRIVE SIDE

Uncouple the pump by removing the U-joint or the coupling and eventually the reductor.

Remove the key and operate in a identical way in § DISMANTLING PUMP ON SIDE OPPOSITE TO DRIVE SYSTEM.

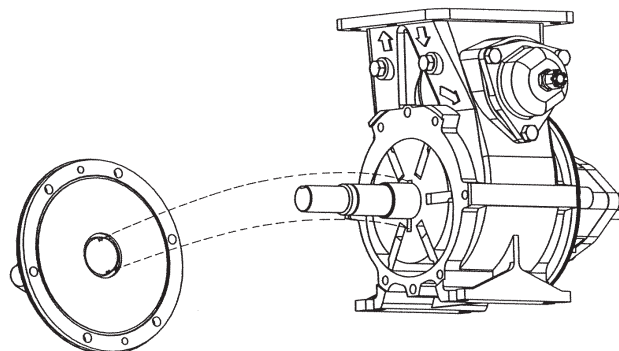

REASSEMBLY OF THE PUMP

When putting the end-plate back into place, take care to have the shaft seal drive lugs facing the notches on rotor.

Replace the cover **712** or **705** on the end plate **401** with screws **723**.

Lubricate the shaft **501** slightly.

Make sure that the end-plate seal **403** is correctly positioned, check it and change it if necessary.

Position the end plate **401** on the shaft and approach it as far as possible by hand.

Finish fitting the end-plate, screwing the 2 nuts **412** gradually on to the 2 screws **411**.

Make sure that end-plate is centred while screwing.

When the end-plate is in place, remove the screws **411** and their nuts **412** and screw them up in the 2 bosses taking care to position one of the drips (situated next to every grease nipple) pointing down.

Replace the screws **410**.

Remove the cover **712** or **705**.

Replace the circlip **537**.

Replace the cover **705**, the seal **707** after check its condition, the seal **714**.

Free the shaft line by a light blow of mallet on its extremity and make sure that the pump rotates freely when turned by hand.

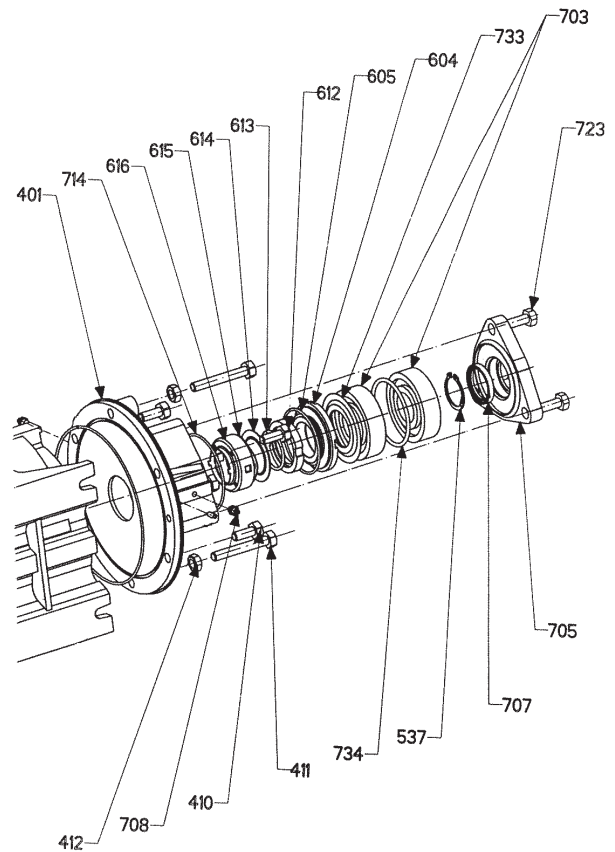

CHANGING THE VANES

Open the pump on one side or the other.

Remove the vanes **317**.

Check for wear (see § MAINTENANCE).

If vane wear is abnormal, check condition of body and of end-plate faces.

Refit the vanes (new if necessary) respecting the direction of assembly.

Reassemble the pump and check that it rotates freely when turned by hand.

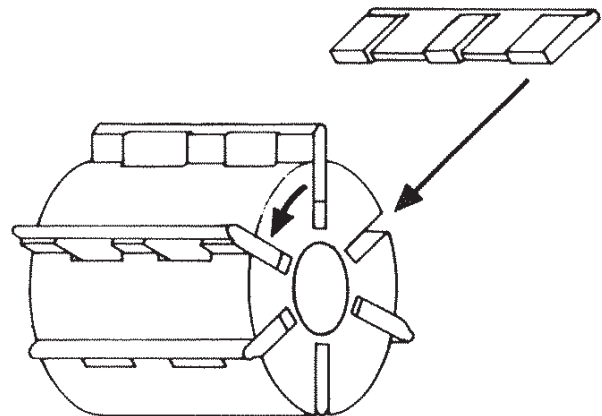

CHANGING MONOBLOC SHAFT SEAL

Disassembly

Remove the end-plate.

Lay it on its machined side taking care not to damage the 2 shaft seal drive lugs.

Remove parts.

Remove shaft seal by inserting fingers in shaft seal center hole.

Reassembly

Refit the shaft seal **630** (a new one if necessary).

Reassemble in reverse order of disassembly.

Make sure that the seals **605** and **613** are in good condition. Change them if necessary.

Refit the end plate (see § REASSEMBLY OF THE PUMP).

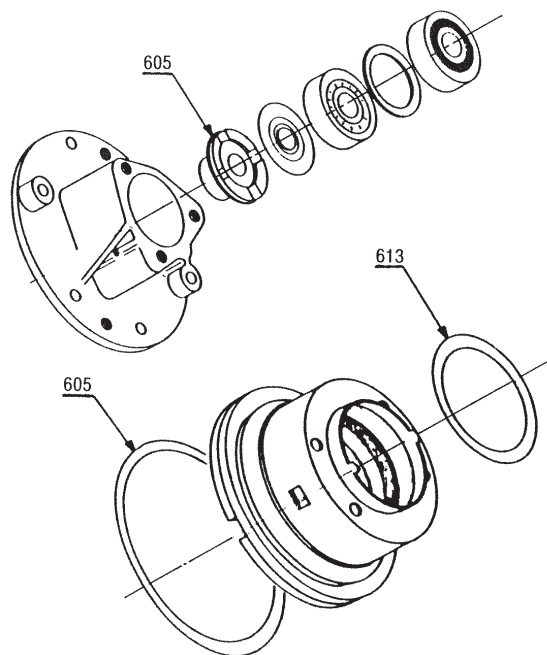

DISMANTLING AND REASSEMBLY OF THE BYPASS

Disassembly

Set bypass at minimal pressure by unscrewing the nut **834** (taking care to count the number of rotations so as to be able to reset bypass at initial pressure setting).

Unscrew the screws **856** of the bypass cap **827**.

Remove spring **824**.

Remove the valve **823** by pulling its cylindrical section with the fingers.

Check condition of bypass.

Reassembly

Clean parts before reassembly.

Reassemble in reverse order of disassembly.

Set bypass at initial pressure setting by tightening nut **834** with the same number of rotations as counted during dismounting.

Tighten lock-nut **835**.

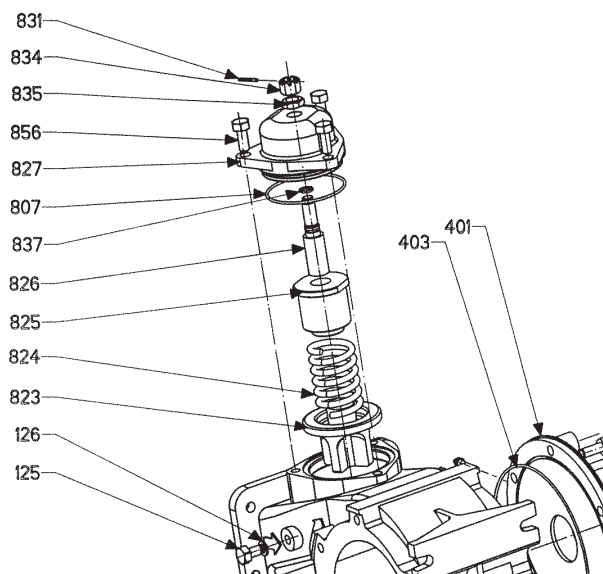

MAINTENANCE

Lubrication of bearings

Foresee periodic lubrication of bearings (see GENERAL INSTRUCTIONS).

Inspection of the vanes

It is necessary to check the conditions of the vanes every 700 operating hours :

PUMP	DIMENSIONS OF THE VANES - mm	
	Original height (H)	Change when "H" <
CC8-40 V	38	34
CC8-65 V	38	35,5

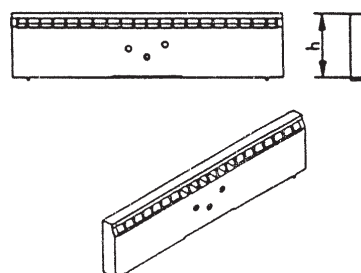

EXPLODED VIEW

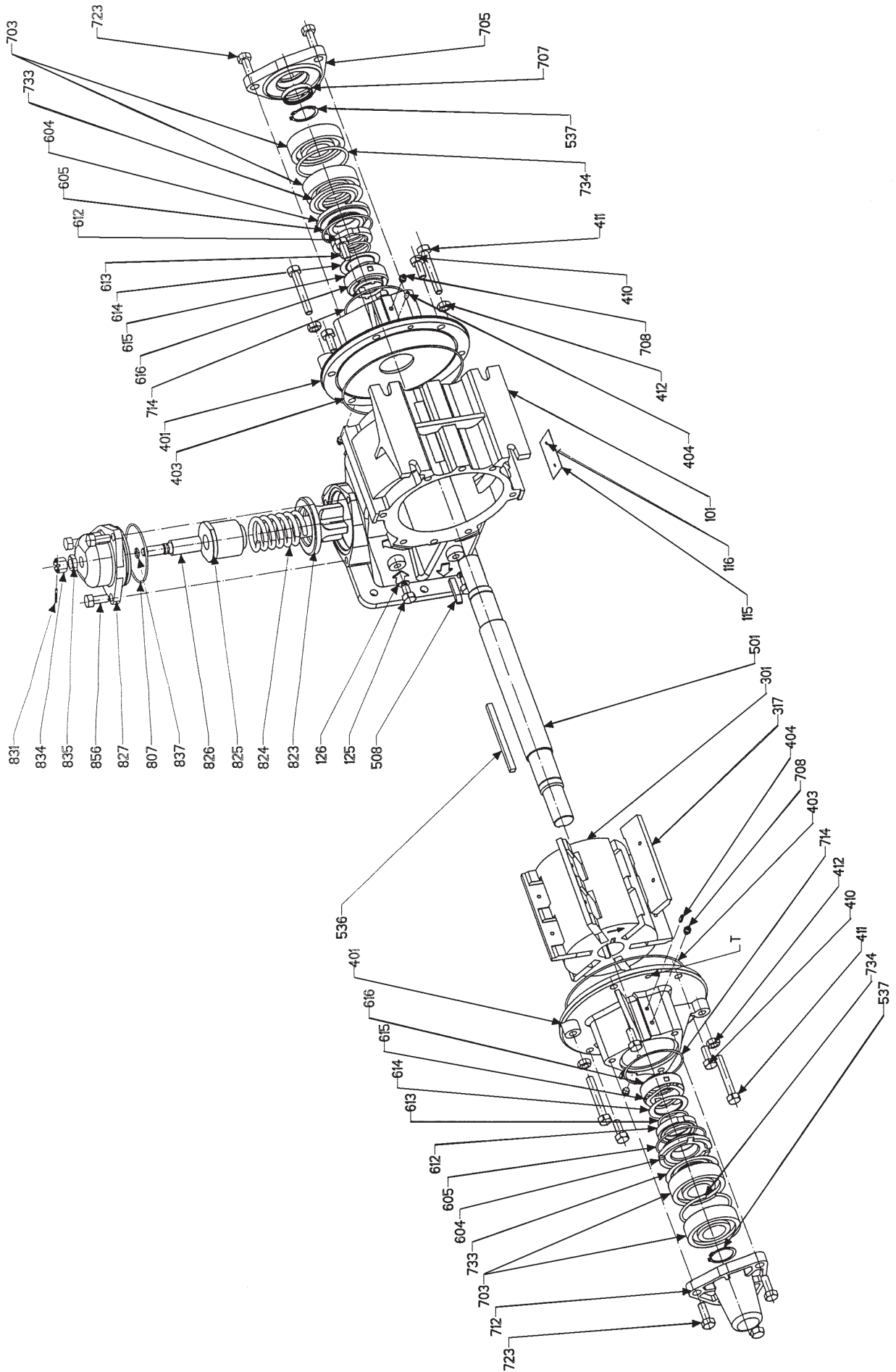

SPARE PARTS

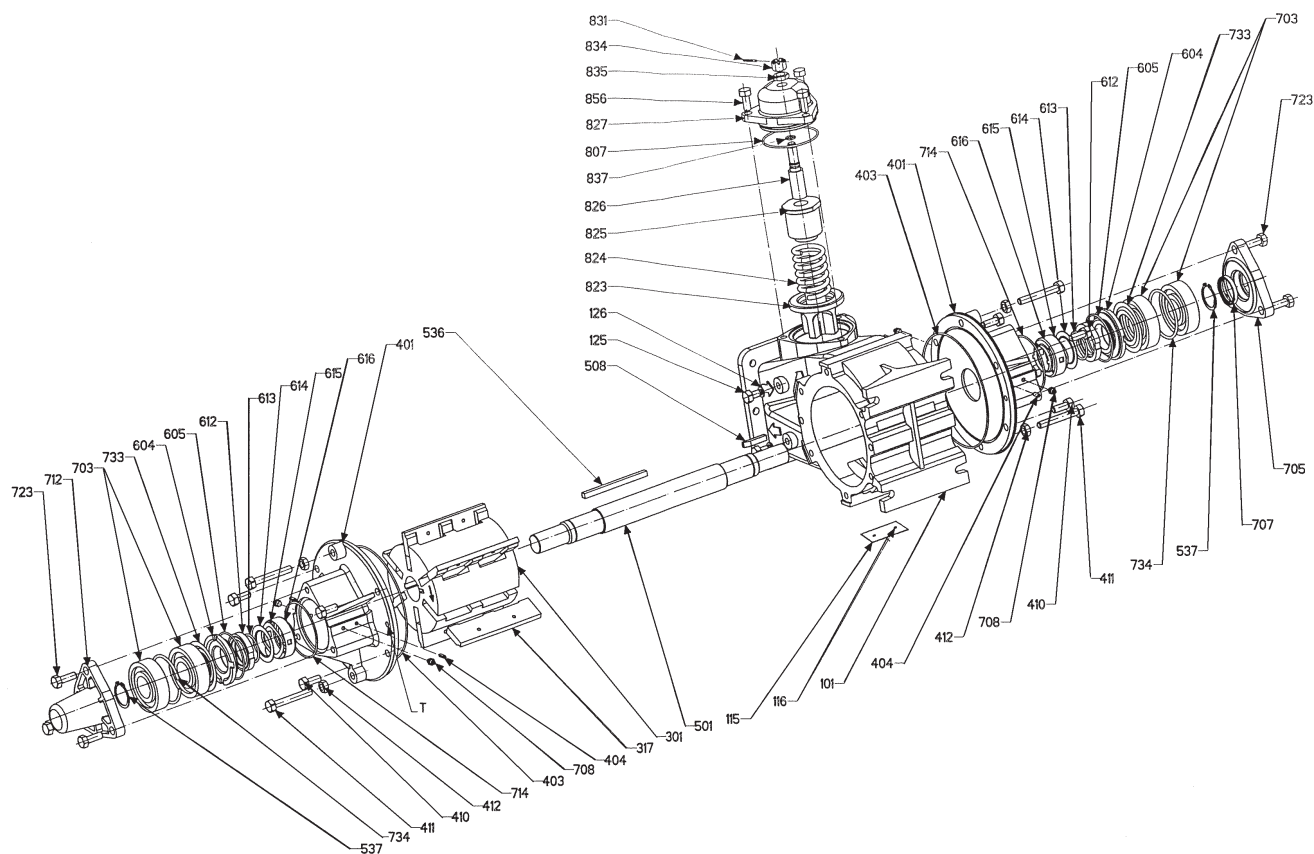

* Sets of parts or parts available to order.

The Ref. corresponds to 1 piece of the reference part or set of parts.

Ex. : 1x rep. 317 = 1 vane - 1 x rep. 309 = 1 set de 6 vanes

REF.	Nb.	DESIGNATION
*098	1	SET OF SCREWS (410+411+412+723+856)
*099	1	SET OF PUMP SEALS (126+403+807)
*100	1	COMPLETE BODY
101	1	Body
108	1	Bypass seat
115	1	Pump plate
116	2	Plate rivet
*124	1	DRAIN PLUG AND SEAL
125	2	Drain plug
126	2	Seal See 099
*300	1	COMPLETE ROTOR
301	1	Rotor
317	6	Vane See 309
*309	1	SET OF 6 VANES 317
*400	2	COMPLETE END PLATE
401	2	End plate
403	2	End plate seal..... See 099 ou 409
410	8	End plate screw See 098
411	4	End plate dismantling screw See 098
412	4	End plate dismantling nut See 098
404	4	Drip hole
*409	1	SET OF 2 END PLATE SEALS 403
*500	1	COMPLETE SHAFT
501	1	Shaft
*599	1	SET OF KEYS
508	1	End shaft key
536	1	Sliding rotor key
537	2	Retainer ring
540	1	Shaft protector

SPARE PARTS (continued)

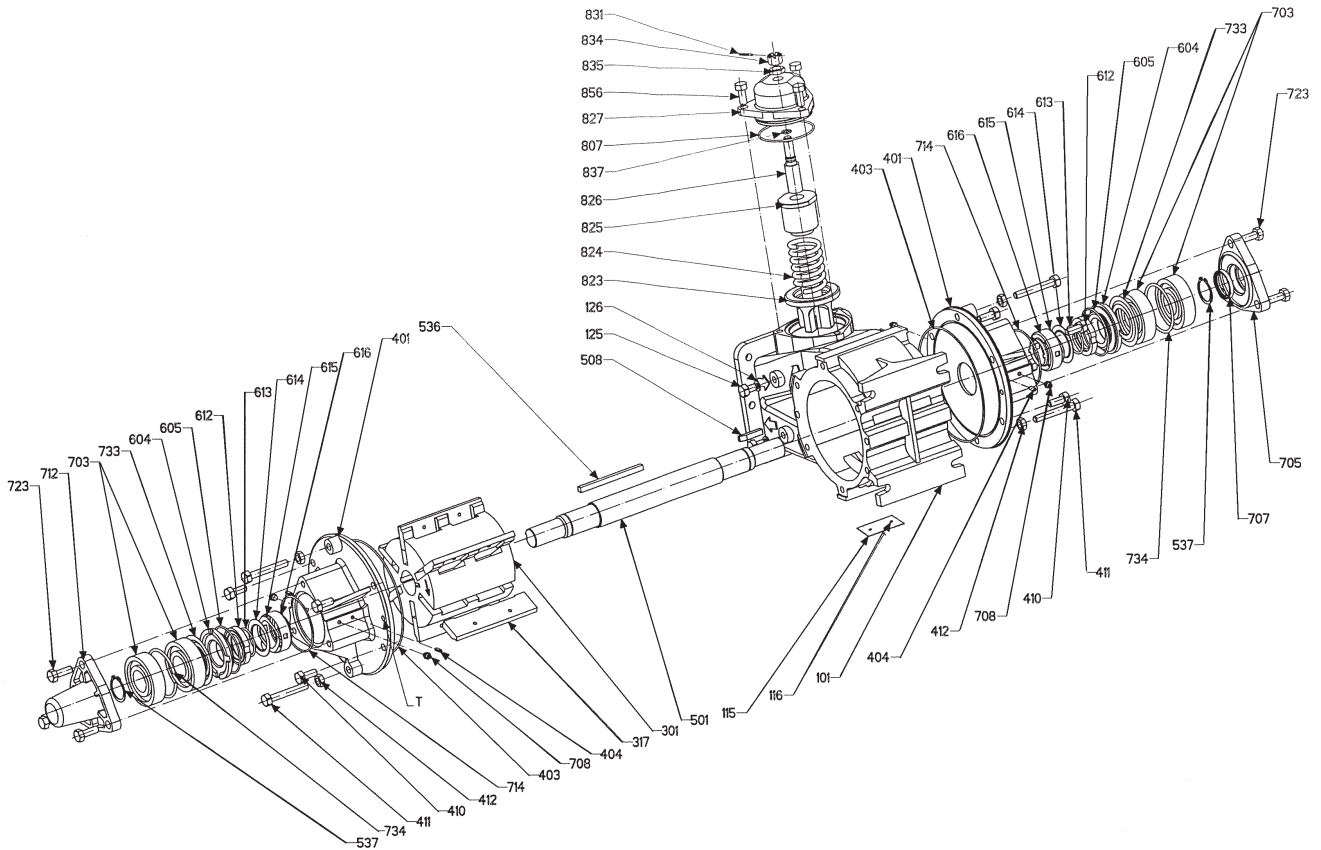

* Sets of parts or parts available to order.

The Ref. corresponds to 1 piece of the reference part or set of parts.

Ex. : 1x rep. 317 = 1 vane - 1 x rep. 309 = 1 set de 6 vanes

REF.	Nb.	DESIGNATION
*630	2	COMPLETE SHAFT SEAL
604	2	Stationary
605	2	Stationary seal.....See 699
612	2	Cup
613	2	Cup sealSee 699
614	2	Spring guide
615	6	Spring
616	2	Retainer shaft seal
*699	1	SET OF SHAFT SEAL SEALS (605+613)
*700	1	COMPLETE BLIND BALL BEARING
703	2	BearingSee 704
708	2	Bearing grease nipple
714	1	Cover sealSee 715
723	3	Cover screwSee 098
733	1	Protection ring
734	1	Spacer
*712	1	Blind cover
*700a	1	COMPLETE BALL BEARING
703a	2	BearingSee 704
705	1	Bearing cover
707	1	LipsealSee 715
708a	2	Bearing grease nipple
714a	1	Cover sealSee 715
723a	3	Cover screwSee 098
733a	1	Protection ring
734a	1	Spacer
*704	1	SET OF 4 BEARINGS 703
*715	1	SET OF COVER SEALS (707+714)

SPARE PARTS (continued)

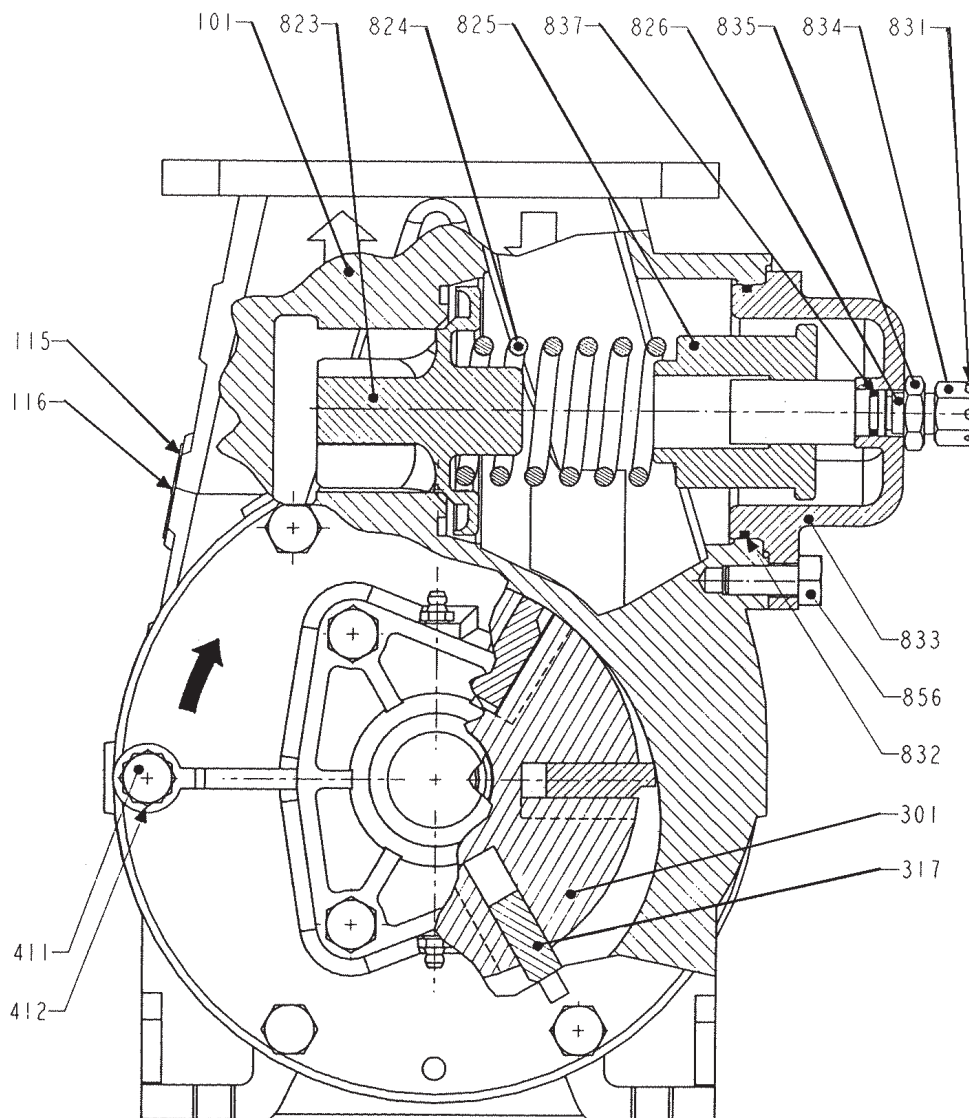

*** Sets of parts or parts available to order.**

The Ref. corresponds to 1 piece of the reference part or set of parts.
 Ex. : 1x rep. 317 = 1 vane - 1 x rep. 309 = 1 set de 6 vanes

REF.	Nb.	DESIGNATION
*820	1	COMPLETE COMPENSATED BYPASS
*823	1	Compensated valve
*827	1	Bypass cup
*898	1	ADJUSTMENT PIN ASSEMBLY
807	1	Seal See 899
825	1	Spring guide
826	1	Pressure screw
831	1	Nut pin See 899
834	1	Adjustment nut See 899
835	1	Lock nut..... See 899
837	1	Adjustment seal See 899
856	4	Cup screw See 098
*824	1	Spring : 4 or 8 bar (to specify)
*899	1	SET OF BYPASS SEALS, SCREWS AND NUTS (807+831+834+835+837)

SPARE PARTS (continued)

PNEUMATIC BYPASS WITHOUT SPRING

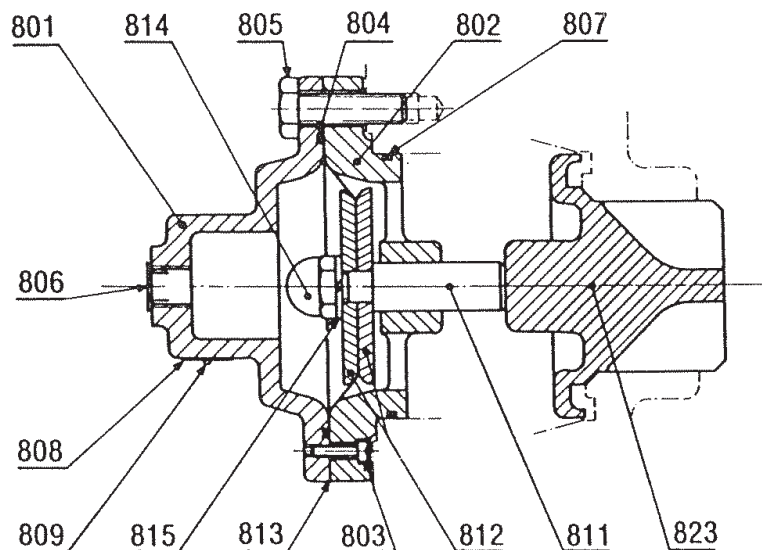

* Sets of parts or parts available to order.

The Ref. corresponds to 1 piece of the reference part or set of parts.
 Ex. : 1x rep. 317 = 1 vane - 1 x rep. 309 = 1 set de 6 vanes

VARIANTE		
REF.	Nb.	DESIGNATION
*800	1	COMPLETE PNEUMATIC BYPASS WITHOUT SPRING
801	1	Bypass cover
802	1	Bypass base
803	2	Cup screw
804	1	Base seal..... See 816
805	4	Bypass fixing screw
806	1	Plug
807	1	Base seal..... See 816
808	1	Plate
809	2	Plate rivet
*823	1	Compensated valve
*810	1	FITTED PUSHROD-DIAPHRAGM UNIT
811	1	Pushrod pin
812	2	Diaphragm washer
*813	1	Diaphragm
814	1	Blind nut
815	1	Lockwasher
*930	1	Regulator, settled, filled
*816	1	SET OF PNEUMATIC BYPASS SEALS 804+807

SPARE PARTS (continued)

PNEUMATIC BYPASS WITH ADJUSTABLE SPRING

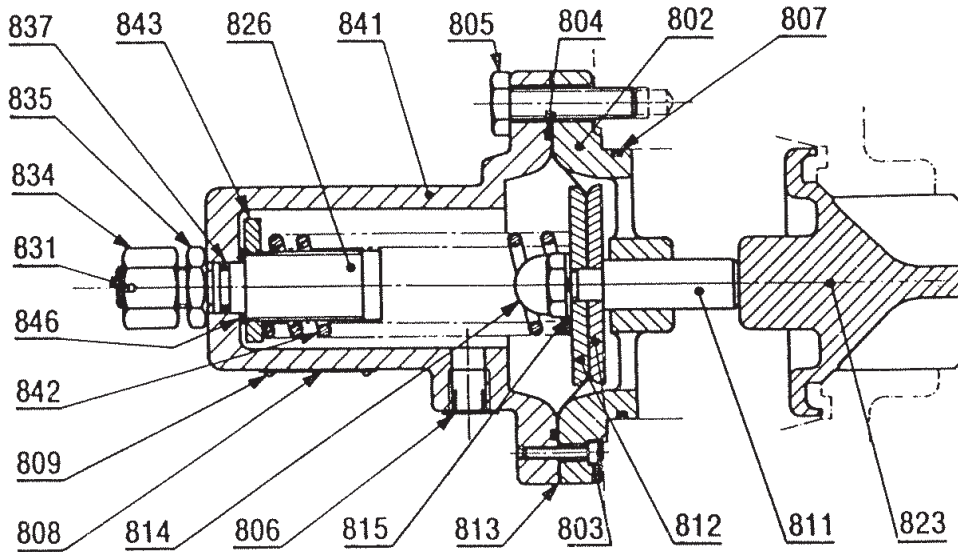

* Sets of parts or parts available to order.

The Ref. corresponds to 1 piece of the reference part or set of parts.
 Ex. : 1x rep. 317 = 1 vane - 1 x rep. 309 = 1 set de 6 vanes

VARIANTE		
REF.	Nb.	DESIGNATION
*840	1	COMPLETE PNEUMATIC BYPASS WITH ADJUSTABLE SPRING
802	1	Bypass base
803	2	Cover screw
804	1	Base seal..... See 844
805	4	Bypass fixing screw
807	1	Base seal..... See 844
808	1	Plate
809	2	Plate rivet
*823	1	Valve
841	1	Bypass cup
*810	1	FITTED PUSHROD-DIAPHRAGM UNIT
811	1	Pushrod pin
812	1	Diaphragm washer
*813	1	Diaphragm
814	1	Blind nut
815	1	Lockwasher
*845	1	ADJUSTMENT PIN ASSEMBLY
826	1	Pressure screw
831	1	Nut pin See 844
834	1	Adjustment nut..... See 844
835	1	Lock nut..... See 844
837	1	Seal See 844
842	1	Spring
843	1	Spring guide
*930	1	Regulator, settled, filled
*844	1	SET OF SEALS AND NUTS (804+807+831+834+835+837)

SPARE PARTS (continued)

SPEED REDUCER FLANGED ON PUMP

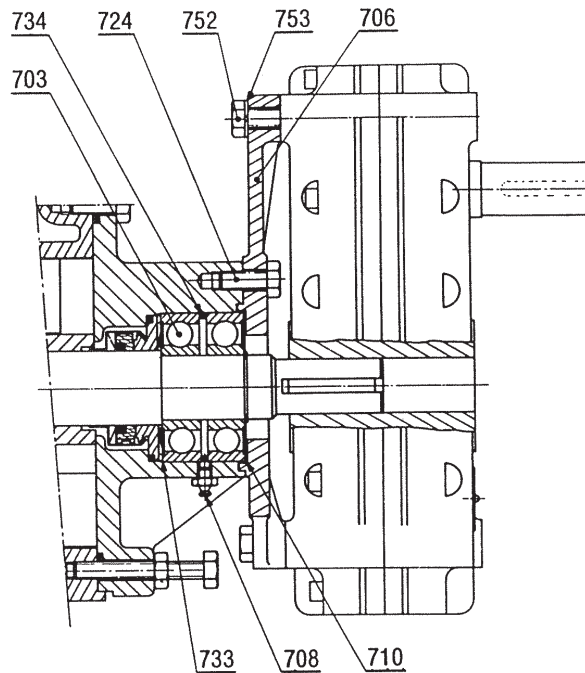

* Sets of parts or parts available to order.

The Ref. corresponds to 1 piece of the reference part or set of parts.

Ex. : 1x rep. 317 = 1 vane - 1 x rep. 309 = 1 set de 6 vanes

VARIANTE		
REF.	Nb.	DESIGNATION
Construction AP		
*700a	1	COMPLETE BALL BEARING FOR SPEED REDUCER
703a	2	Bearing greased for life
*706	1	Reduction gear side plate
*710	1	Shim
724	3	Side-plate screw
733a	1	Protection ring
734a	1	Grease nipple
752	4	Reductor screw
753	4	Lock washer
Construction CP identical to the above except for :		
*700	1	COMPLETE BALL BEARING FOR SPEED REDUCER
703a	2	Bearing
708	2	Grease nipple

When ordering spare parts, please indicate :

- TYPE and SERIAL NUMBER of pump (stamped on pump plate)
- The REFERENCE and DESIGNATION of parts required. Take due note that only spares (complete assemblies or detail parts) identified by (*) can be supplied.
- INSTRUCTIONS 1010-E00.