



INSTRUCTIONS 1010-G00 e

Section	1010
Effective	April 2004
Replaces	303 D

Translation of the
original instructions

CC8-65 EP PUMP

INSTALLATION

OPERATION

MAINTENANCE

**BLACKMER
ZI PLAINE DES ISLES
F- 89000 AUXERRE**

Tel. : +33 3.86.49.87.13
Fax : +33 3.86.49.87.17
e-mail : contact@blackmer-mouvex.com

Your distributor :

1. PRESENTATION

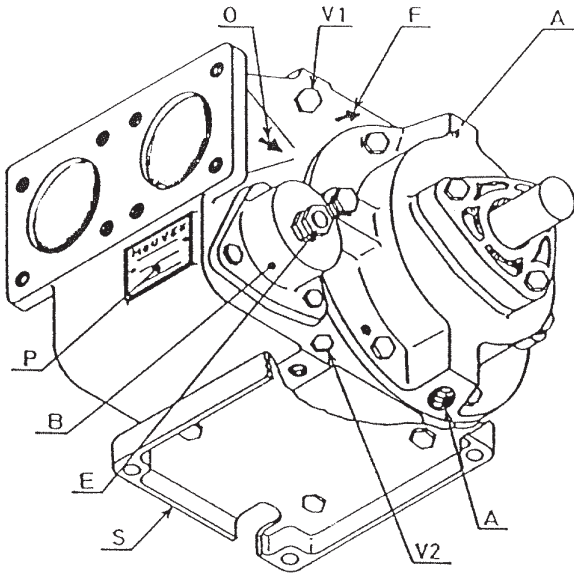

A	Heating-shell ports
B	Bypass
F	Arrow rotation
E	Bypass adjustment
J	End plate dismounting
O	Arrow suction
P	Pump plate
S	Special baseplate for clearing heating lines
V1	Drain/Vaccum plug - G1/2
V2	Drain/Pressure plug M10

2. OVERALL DIMENSIONS

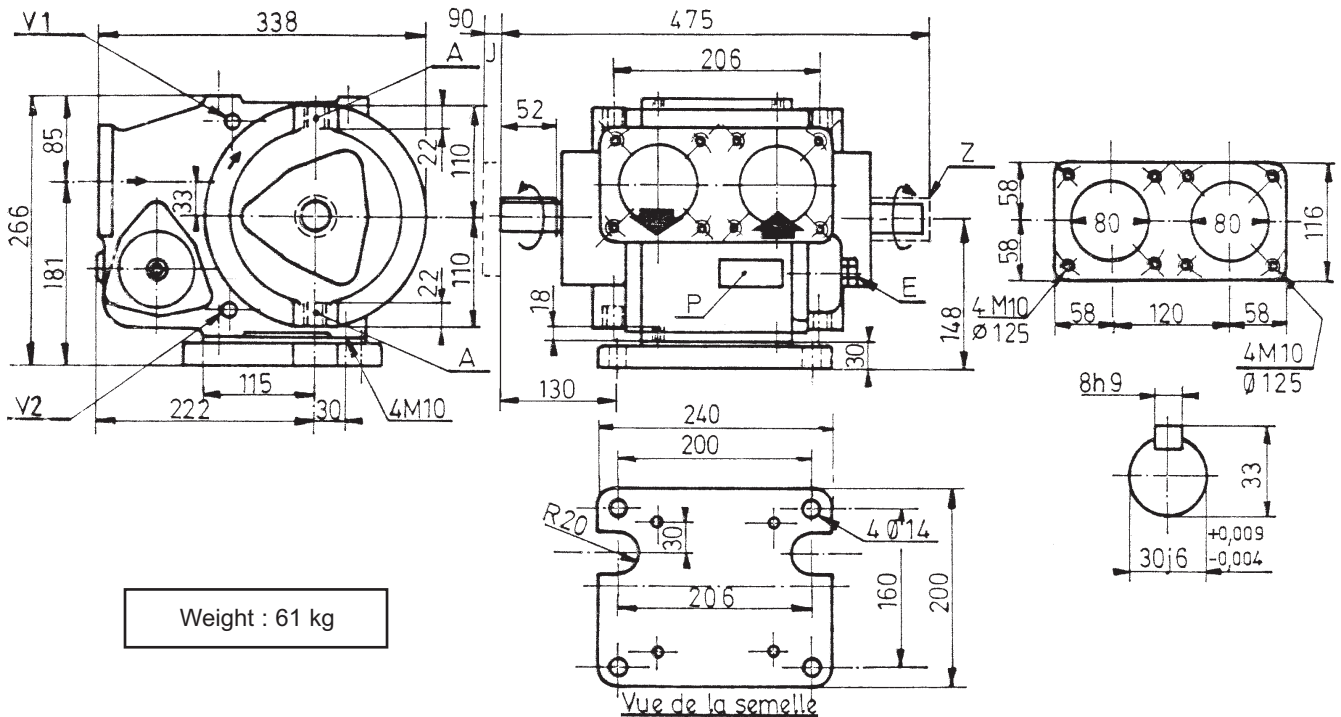

The pump has only one direction ; depending on that of the power take-off, it will be driven by one end of the shaft or the other. In both cases, the position of the intake and discharge ports as well as that of the bypass remain fixed. It allows, nonetheless, rotation in the reverse direction at low speed and pressure to drain the lines.

3. CHARACTERISTICS

Speed of rotation (rpm)	Maximum viscosity (Cst)	Flow at 600 Cst m ³ /h	Max. ref. pressure (bar)	Input power at 6 b. - kw
50	2000	3	6	0.8
400	2000	24	6	5.5
550	1500	33	6	7.5
700	600	43	6	9.5

The CC8-65 EP pump is delivered exclusively with an adjustable-spring bypass.

Do not exceed the maximum permissible pressure, or 6 bar.

4. ASSEMBLY / DISMANTLING

Before any disassembly, make sure that the pump has been drained. In addition, before opening the pump, the end-plate heating system must be disconnected.

4.1 NECESSARY TOOLS

- Flat spanners 13 - 17 - 22
- Tubular socket spanner 17
- Opening circlip pliers
- Screwdriver

4.2 OPENING UP OF THE PUMP AT NON-DRIVE SIDE

Loosen the screws **723** and remove the end-cover **705**.

Remove the circlips **537**.

Carefully clean the shaft end to remove any traces of paint, oxidation, burrs, etc...

Loosen the 4 screws **410**.

Loosen the 2 screws **411** fitted with their nuts, and place them in the 2 tapped holes T.

Screw these 2 bolts simultaneously so that the cover is progressively uncoupled from the axle. When the cover is free on the shaft, withdraw it manually while supporting it.

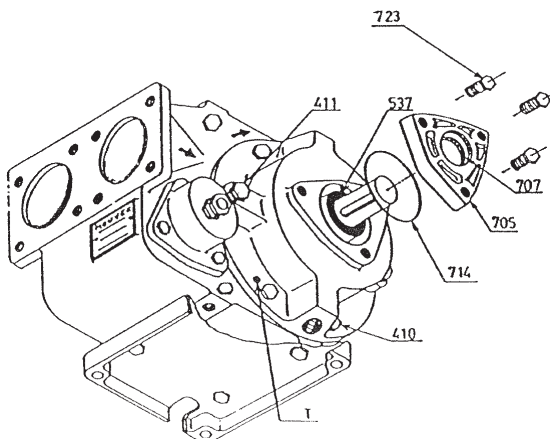

4.3 OPENING OF THE PUMP AT DRIVE SIDE

Uncouple the pump by removing the cardan or the coupling sleeve and eventually the reductor.

Remove the key, carefully clean the shaft end then proceed in an identical manner to the disassembly at non-drive side.

4.4 RE-ASSEMBLY

Fit the end-cover **705** on the cover using the screws **723**.

Slightly lubricate the shaft **501**.

In the re-assembly operation, make sure the O-ring **403** is positioned accurately. Check it and change it if necessary.

Position the cover on the shaft and advance it as far as possible by hand positioning the drive spigots of the shaft O-ring opposite the slots of the rotor as well as pin **402** in the housing. Don't forget the O-ring **403**. The end-plate on the discharge side cannot be interchanged with the end-plate on the intake side.

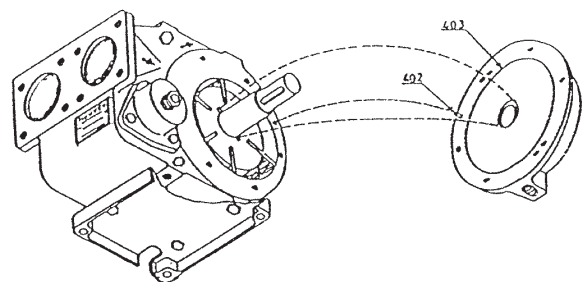

4. ASSEMBLY / DISMANTLING (continuous)

Finish fitting the end-plate by gradually screwing the 2 nuts **412** onto the 2 screws **411**.

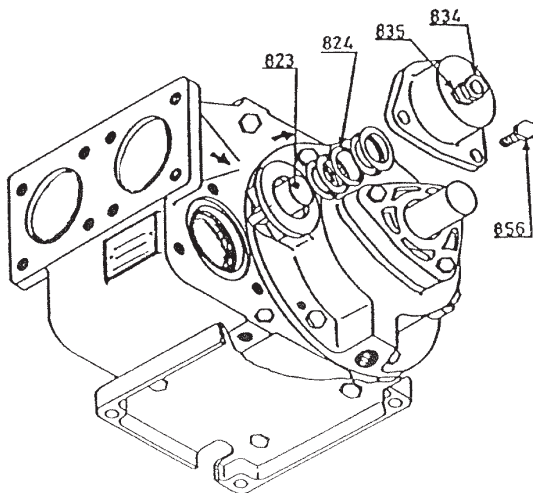
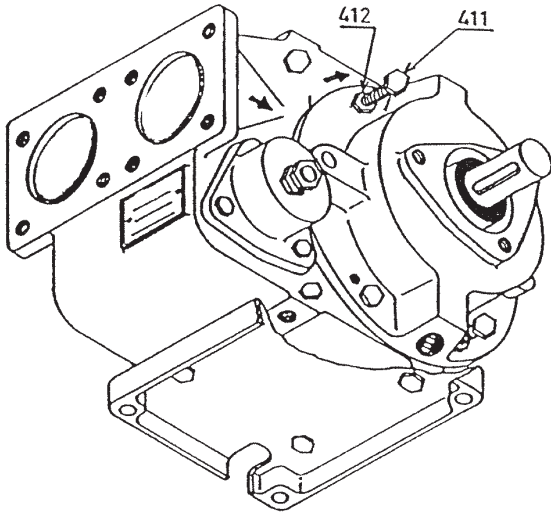

Make sure that the end-plate lies on the center line while it is being screwed down.

When the end-plate is installed, remove screws **411** fitted with their nuts **412** and screw them into the 2 bosses.

Put screws **410** back in place.

Remove the end-cover **705**, fit the circlips **537** and refit the cover **705**, checking seals **707** and **714**.

Free the shaft line by a slight blow with a mallet at its ends and make sure that the pump turns freely by hand.

Screws **411**, which are longer, are to be screwed back into the holes in the end-plate having 2 bosses.

4.5 TO CHANGE THE VANES

Open the pump on the drive side.

Remove from the remaining end-plate the 4 screws **410**, the 2 screws **411** and take out the vanes **317** as well as the 3 pushrods **318**. Check the vanes and pushrods for wear. (see § MAINTENANCE).

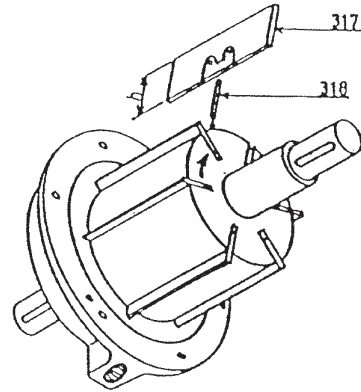

In case of abnormal wear, check the surface of the body and the faces of the end-plate. Refit the pushrods, making the holes in the rotor and the shaft coincide and making sure that the packing drive spigots are facing the notches in the rotor (see § REASSEMBLY).

Refit the vanes (new if necessary), orienting them correctly.

Reinstall the end-plate/shaft/rotor assembly, making sure that the end-plate seal is in the right position. Check it and replace it if necessary.

Complete reassembly of the pump by reinstalling the other end-plate and check that it can be turned easily by hand.

4. ASSEMBLY / DISMANTLING (continuous)

4.6 CHANGING OF SINGLE-PIECE PACKING (item 630)

DISMANTLING

Open the pump and lay the end-plate on its machined side, being careful not to damage the 2 packing drive spigots as well as the positioning pin (in the case of assembly with speed-reduction gearing, remove bolts **724** from the reduction gear side plate **706** and take off the shim **710**).

Remove the parts.

Take out packing **630** by pulling on it with the fingers inside its bore.

RE-ASSEMBLY

Refit the packing (new if necessary).

Reassemble all the parts in reverse order with respect to disassembly (do not forget shim **710** when assembling with a speed reducer).

In this operation, make sure that gaskets **605** and **613** are good.

Refit the end-plate (see § OPENING PUMP ON SIDE OPPOSITE DRIVE SIDE).

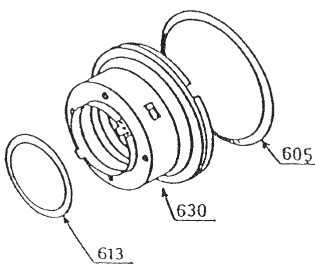
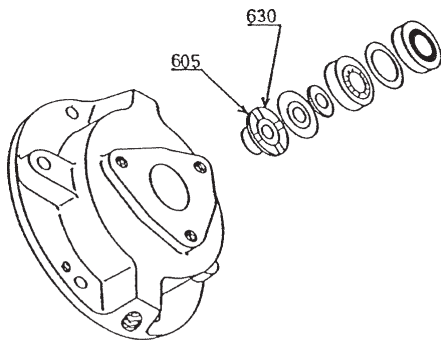

4.7 DISMANTLING AND RE-ASSEMBLY OF THE BYPASS FOR VISIT

DISMANTLING

Set the bypass to the minimum pressure by fully unscrewing nut **834**.

Note the number of turns made when unscrewing it so as to be able to set the bypass to the same pressure when reassembling.

Remove the 3 screws **856** from the bypass cap.

Take out the spring **824**.

Remove the poppet **823** by pulling on its cylindrical section with the fingers.

Check the bypass.

Clean all parts prior to reassembly.

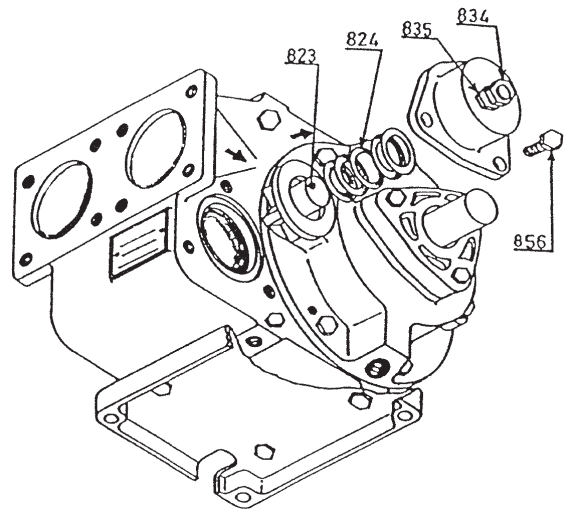

RE-ASSEMBLY

Reassemble in reverse order with respect to disassembly.

Set the bypass to the pressure desired by retightening nut **834** the number of turns note when disassembling.

Tighten down lock nut **835**.

5. MAINTENANCE

Aside from greasing the bearings periodically with high-temperature grease (for ex. ENERGREASE HTG2-BP), it is necessary to check, every 500 hours :

- condition of the vanes :

Original height : $h = 38 \text{ mm}$
replace them if : $h < 36 \text{ mm}$

- condition of the pushrods :

Original height : $h = 79 \text{ mm}$
replace them if : $h < 78 \text{ mm}$

- surface condition of the body and end-plates ; if there is extensive grooving, an overhaul is required.
- condition of the bypass. Clean it if dirty.

6. SPARE PARTS

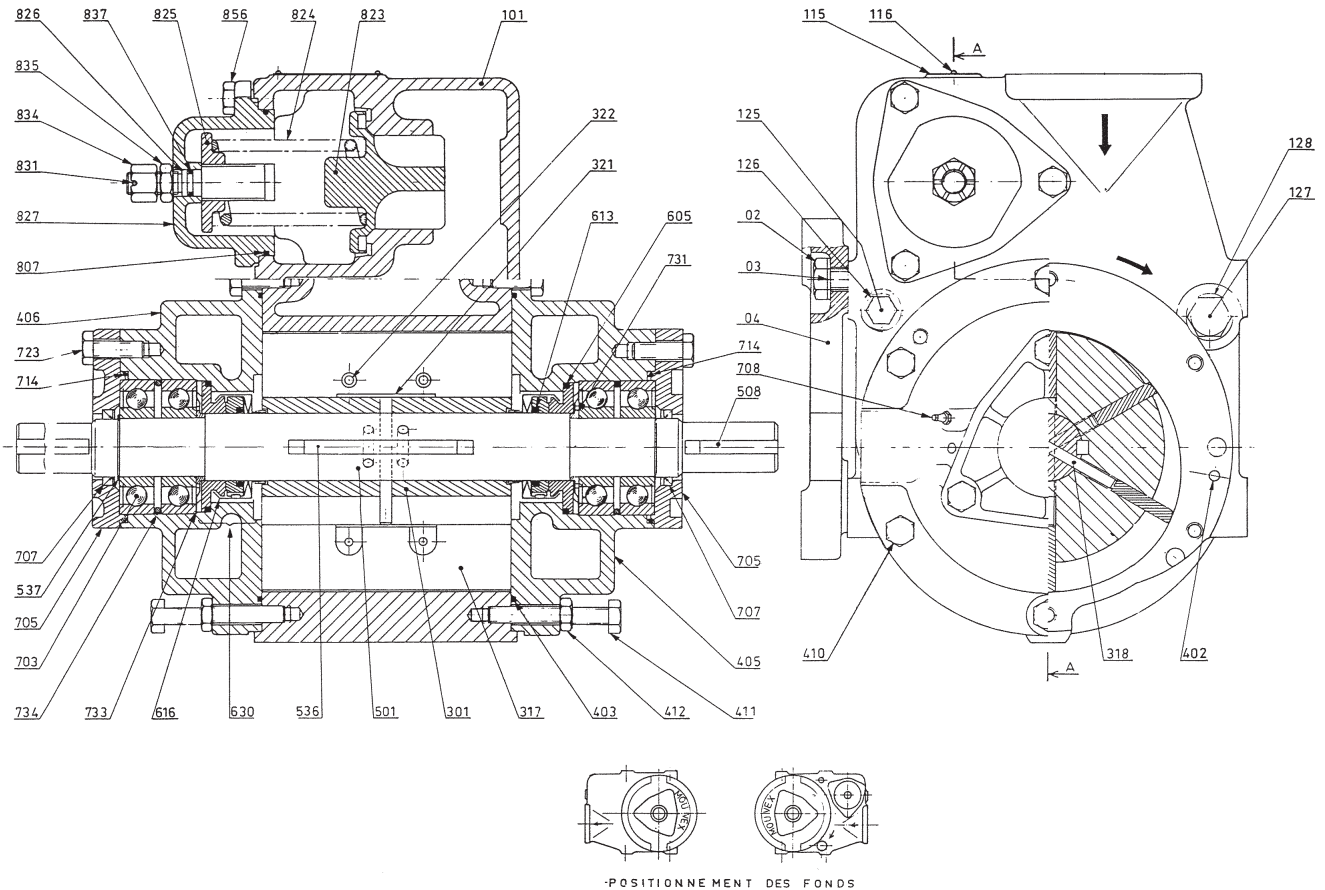

° Sets and parts available to supply.

Rep	Nb	DESIGNATION
°	098	1 SET OF SCREWS (410 + 411 + 412 + 723 + 856)
°	099	1 PUMP SET GASKETS (126 + 128 + 403 + 807)
°	100	1 COMPLETE BODY
	101	1 Body
	115	1 Pump plate
	116	2 Plate rivet
°	124	2 DRAIN PLUG AND SEAL
	125	1 Drain plug
	126	1 Seal (see 099)
	127	1 Drain plug
	128	1 Seal (see 099)
°	300	1 ROTOR COMPLETE
	301	1 Rotor
	317	6 Complete vane (see 319)
	316	1 Vane
	318	3 Pushrod
	321	1 Pushrod insert
	322	2 Rivet
°	319	1 SET OF 6 VANES 317
°	400	2 COMPLETE FRONT COVER
	405	1 Front cover side discharge
	406	1 Front cover side suction
	402	2 Pin
	410	8 Front cover screw (see 098)
	411	4 Dismantling front cover screw (see 098)
	412	4 Dismantling front cover nuts (see 098)
	403	2 FRONT COVER SEAL (see 099 and 409)
°	409	1 SET OF 2 FRONT COVER SEAL 403

6. SPARE PARTS (continuous)

Rep	Nb	DESIGNATION
°	500	1 COMPLETE SHAFT
°	505	1 EQUIPED SHAFT
	501	1 Shaft
	731	2 Bushing
°	599	1 SET OF KEYS, COMPLETE
	508	1 Shaft end key
	536	1 Sliding rotor key
	537	2 Retaining ring
	540	1 Shaft end protector
°	630	2 MONOBLOC GASKET, COMPLETE
	604	2 Stationary part
	605	2 Stationary part seal..... (see 699)
	612	2 Cup
	613	2 Cuvette seal..... (see 699)
	614	2 Spring guide
	615	3 Spring
	616	2 Gasket cage
	618	2 Plate
°	699	1 SET OF GASKETS SEALS (605 + 613)
°	700	2 BALL BEARINGS COMPLETE
	703	2 Bearing (see 704)
	705	1 Cover bearing
	707	1 Leap seal (see 715)
	708	2 Lubricator
	714	1 Cover seal (see 715)
	723	3 Cover screw..... (see 098)
	733	1 Protection circlip
	734	1 Spacer
°	704	1 SET OF 4 BEARINGS 703
°	715	1 SET OF COVER SEALS (707 + 714)
°	820	1 COMPENSATED BYPASS, COMPLETE
°	823	1 Compensated valve
°	827	1 Cap
°	898	1 PRESSURE SCREWS ASSEMBLY
	807	1 Seal (see 899)
	825	1 Spring support
	826	1 Pressure screw
	831	1 Nut pin (see 899)
	834	1 Adjusting nut..... (see 899)
	835	1 Lock nut..... (see 899)
	837	1 Adjustment seal (see 899)
	856	3 Screw cap..... (see 098)
°	824	1 Spring
°	899	1 SET OF SEALS AND BYPASS NUTS (807 + 831 + 834 + 835 + 837)

6. SPARE PARTS (continuous)

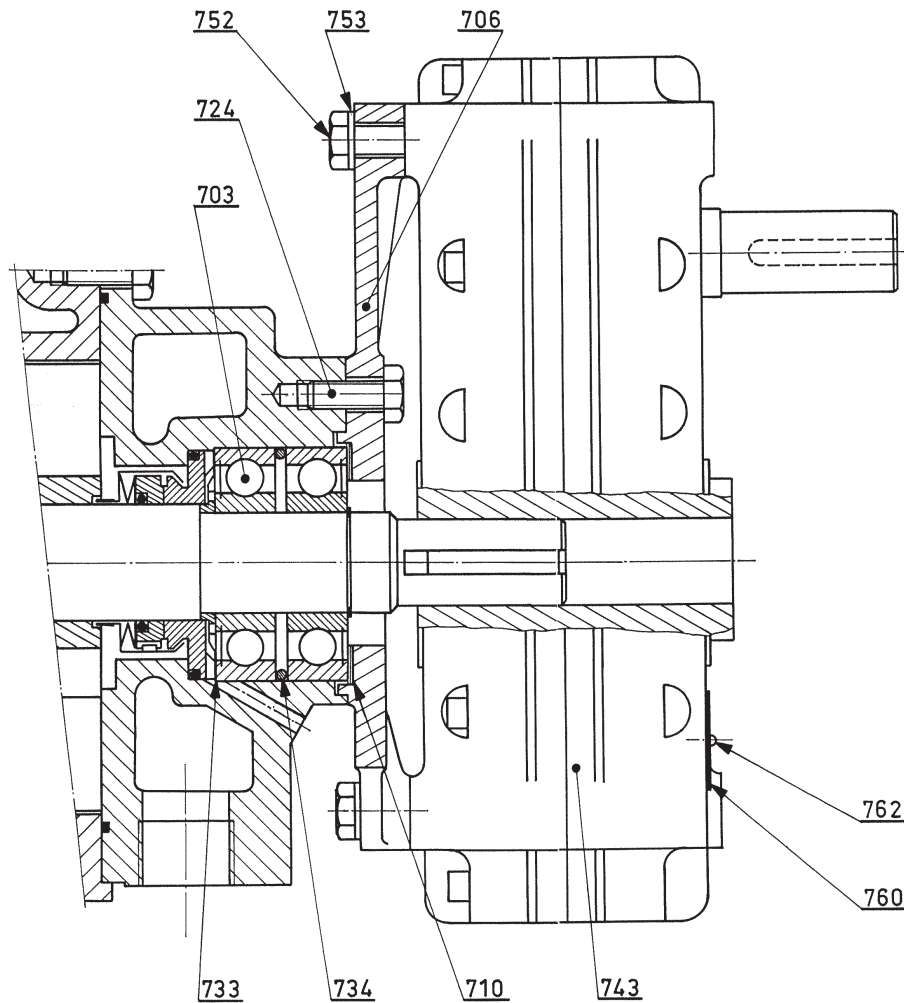

VARIANTES

Ref	Nb	DESIGNATION
° 001	1	COMPLETE PUMP BASEPLATE
002	4	Baseplate bolt
003	4	Lock washer
004	1	Pump baseplate
° 700a	1	COMPLETE BALL BEARING FOR SPEED REDUCER
703	2	Bearing
° 706	1	Reduction gear side plate
708	1	Grease nipple
° 710	1	Shim
724	3	Side-plate screw
733	1	Protection ring
734	1	Spacer
752	4	Reductor screw
753	4	Lock washer

When ordering spare parts, mention :

- . the TYPE and the SERIAL NUMBER of the pump
- . INSTRUCTIONS 1010-G00 with his revision
- . the REFERENCE and DESIGNATIONS of the parts required (° : Assemblies and parts available for supply)