



**NOTICE D'INSTRUCTIONS 1010-K00 e**

Rubrique	1010
En vigueur	June 2007
Remplace	New

Original instructions

# ***Assembly of flange for GT reduction gear or hydraulic trunk on pump CC8***

**BLACKMER  
ZI PLAINE DES ISLES  
F- 89000 AUXERRE**

Tél. : +33 (0)3.86.49.87.13  
Fax : +33 (0)3.86.49.87.17  
e-mail : [contact@blackmer-mouvex.com](mailto:contact@blackmer-mouvex.com)

**Your Distributor :**

# Assembly of flange for GT reduction gear or hydraulic trunk on pump CC8

- Remove the seal.
- Remove the 3 screws **723** and the bearing cover **705** (see NT 1010-D00).
- Place flange **706** or trunk **757** with the 1mm thick peel-off shim **710** on base **401**. Secure the flange or the trunk with screws **724** without tightening them
- Measure the dimension X using a set of gauge blocks.
- After removing the flange or trunk, reduce the thickness of the peel-off shim to E where:

$$E = 1 - (X - 0,1) \text{ mm} \quad (X = \text{base/flange or trunk play})$$

(layer of thickness 0.1mm)

For this procedure follow the use recommendations below:

Place the sharpened side of the knife against the edge of the shim, **①** as close as possible to the upper face, and press lightly, sliding the tool towards this face.



The edge of the 1st sheet will come away slightly under the action of the knife's point. **②**



Continue detaching the sheet by sliding it under the tool's point. **③** Hold it against the tool with your thumb while continuing to pull.



If two sheets have started to come away at the same time, push the second sheet back down towards the face. **④**



Finish detaching the sheet by pulling it in a parallel direction to the face. **⑤**



N.B. If several sheets have to be removed to obtain the final dimension, detach them one by one.

- Once again place flange **706** or the trunk with peel-off shim **710** on base **401** and tighten screws **724**.

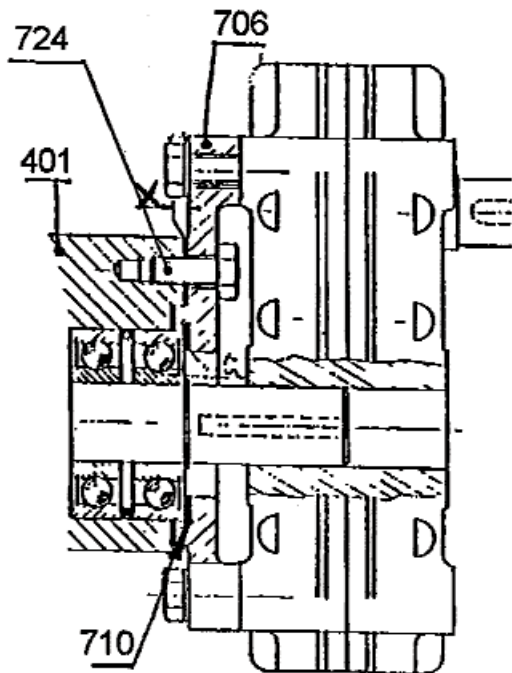

Assembly of GT reduction gear flange

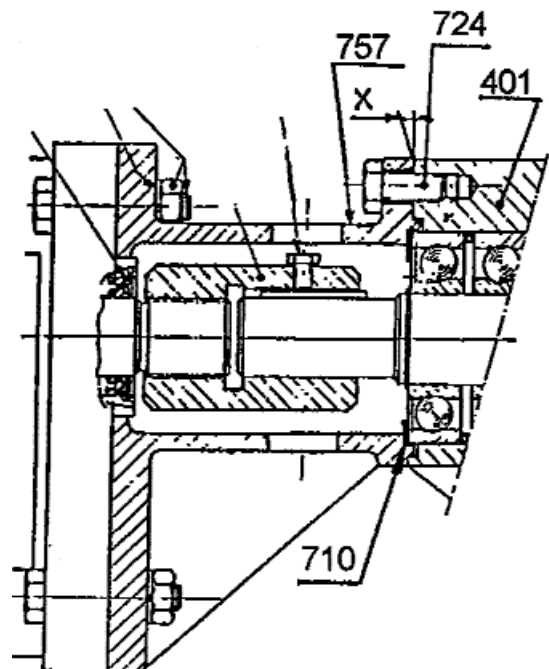

Assembly of hydraulic trunk