

# *C24 i - C36 i*

## *PUMPS*



**INSTALLATION**

**OPERATION**

**MAINTENANCE**

# ECCENTRIC PISTON PUMP MOUVEX PRINCIPLE

## SAFETY INSTRUCTIONS, STORAGE, INSTALLATION AND MAINTENANCE C24 i - C36 i MODELS

### TECHNICAL CHARACTERISTICS

- Maximum pump speed : **460 rpm**
- Maximum running temperature :
  - **PTFE L seals** ..... 80°C
  - **other seals** :
    - \* continuous ..... 100°C
    - \* washing/rinsing/sterilisation ..... 121°C
- Maximum suction pressure :
  - In normal use, the suction pressure must be higher than the required NPSH and **less than 2 bar** (29 psi).
  - During **CIP/SIP** of the pump, the suction pressure must not exceed **3 bar** (43,5 psi).
  - Pump **stopped**, the pressure must not exceed **6 bar** (87 psi).
- Maximum differential pressure :
  - C24 i ..... 9 bar (130,5 psi)\*
  - C36 i ..... 6 bar (87 psi)\*
- Cylinder capacity :
  - C24 i ..... 0,946 litre
  - C36 i ..... 1,420 litre
- Informations about PTFE L seals :
  - This seal is composed of fibreglass.
  - **CAUTION : This seal does not accept thermal shock and Clean In Place.**

\* When the pump works with an inlet pressure less than zero, the maximum outlet pressure will be calculated as if the inlet pressure is equal to zero.



Pump N° :

Commissioning date :

### SAFETY INFORMATIONS



#### This is a SAFETY ALERT SYMBOL

When you see this symbol on the product, or in the manual, look for one of the following signal words and be alert to the potential for personal injury, death or major property damage.



Warns of hazards that **WILL** cause serious personal injury, death or major property damage



Warns of hazards that **CAN** cause serious personal injury, death or major property damage.



Warns of hazards that **CAN** cause personal injury or property damage.

#### NOTICE

Indicates special instructions which are very important and must be followed.

### SUMMARY

*Page*

<b>1. OVERALL DIMENSIONS</b> .....	<b>3</b>
<b>2. INSTALLATION</b> .....	<b>7</b>
2.1 Orientation of the pump ports .....	7
2.2 Direction of rotation .....	7
2.3 Protection of the pump installation .....	7
2.4 Hoisting devices .....	8
2.5 Unit Assembly .....	8
<b>3. UTILISATION</b> .....	<b>10</b>
3.1 Noise level .....	10
3.2 Commissioning .....	10
3.3 Dry running .....	10
3.4 Pump stop .....	10
<b>4. CLEAN IN PLACE (CIP) &amp; STERILISATION IN PLACE (SIP)</b> .....	<b>11</b>
4.1 General .....	11
4.2 CIP circuit recommended .....	11
4.3 Pumps arranged in series .....	11
4.4 Pumps arranged in parallel .....	12
4.5 Successive cycles .....	13
4.6 Sterilisation In Place (SIP) .....	13
<b>5. MAINTENANCE</b> .....	<b>13</b>
5.1 Necessary tools .....	13
<b>6. OPENING OF THE PUMP</b> .....	<b>14</b>
6.1 Assembly / Dismantling .....	14
6.2 Checking of parts .....	15
<b>7. ASSEMBLY OF CYLINDER/PISTON</b> .....	<b>16</b>
<b>8. PROTECTION OF THE BELLOWS</b> .....	<b>17</b>
<b>9. CHANGING THE LIP SEAL</b> .....	<b>18</b>
<b>10. CHANGING THE ORIENTATION OF THE PORTS</b> .....	<b>19</b>
10.1 Discharge port .....	19
10.2 Suction port .....	19
<b>11. DRAINING OF BEARING</b> .....	<b>20</b>
<b>12. OPTIONS</b> .....	<b>21</b>
12.1 Liquid detector .....	21
12.2 Bellows monitoring system .....	21

# 1. OVERALL DIMENSIONS

## C24 i - C36 i with connections

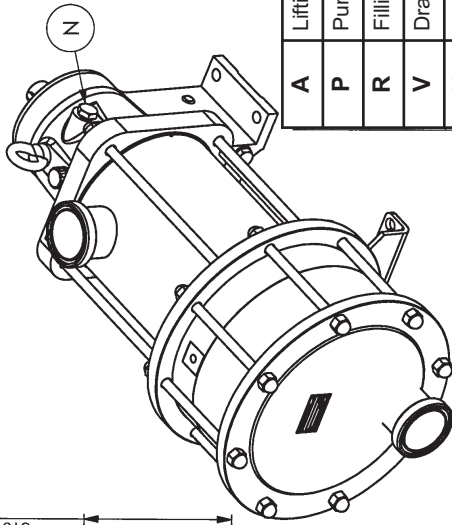
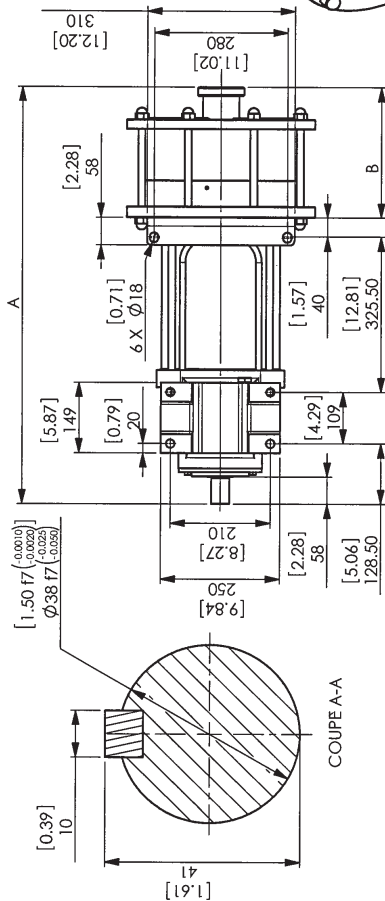

<b>A</b>	Lifting ring
<b>P</b>	Pump plate
<b>R</b>	Filling / Breather
<b>V</b>	Draining
<b>N</b>	Oil level

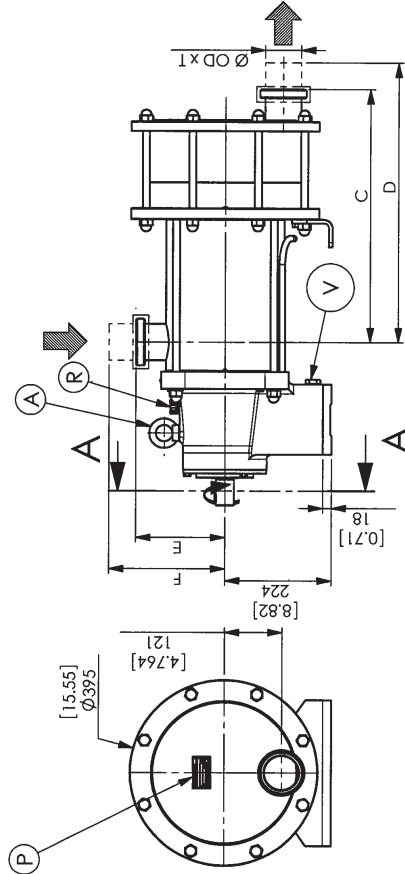

		Connections											
		DN	A	B	C	D	E	F	OD x T	Weight			
SMS 1145	C24i	76	879	276	533.5	566.5	187	220	76.1 x 1.6	185			
	C36i	76	905.5	302.5	560	593	187	220	76.1 x 1.6	[408]			
Clamp (ISO 2852)	C24i	76	879	276	533.5	566.5	187	220	76.7 x 1.9	185			
	C36i	76	905.5	302.5	560	593	187	220	76.7 x 1.9	[408]			
RJT (BS 4825-5)	C24i	76	879	276	533.5	543.5	187	197	76.45 x 1.725	185			
	C36i	76	905.5	302.5	560	570	187	197	76.45 x 1.725	[408]			
Cherry Burrel	C24i	76	879	276	533.5	566.5	187	220	76.2 x 1.65	185			
	C36i	76	905.5	302.5	560	593	187	220	76.2 x 1.65	[408]			
DIN 11851	C24i	80	879	276	533.5	566.5	187	220	87 x 3	185			
	C36i	80	905.5	302.5	560	593	187	220	87 x 3	[408]			

# 1. OVERALL DIMENSIONS (continued)

## C24 i - C36 i

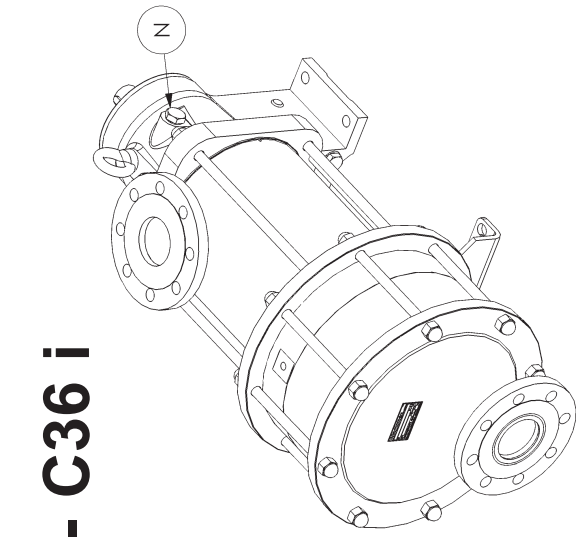

PN16  
Type 01

Shrunk on and  
welded pipe

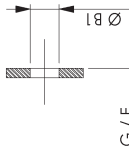

PN20  
Type 12B

Shrunk on and  
welded pipe

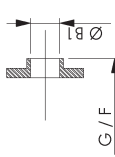

Others

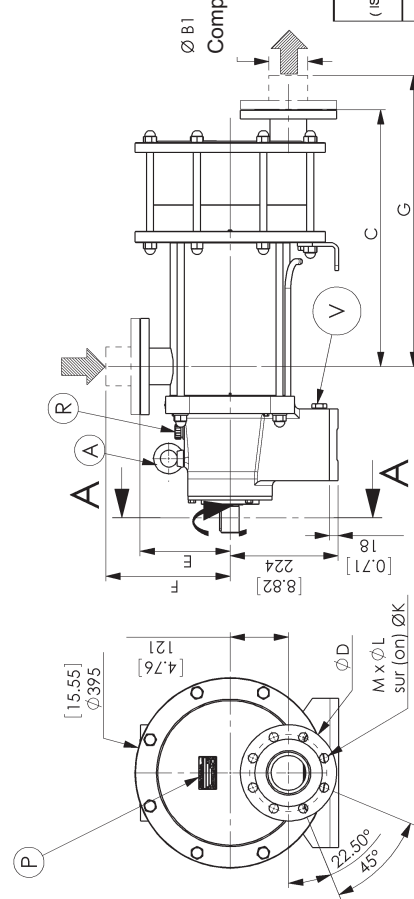
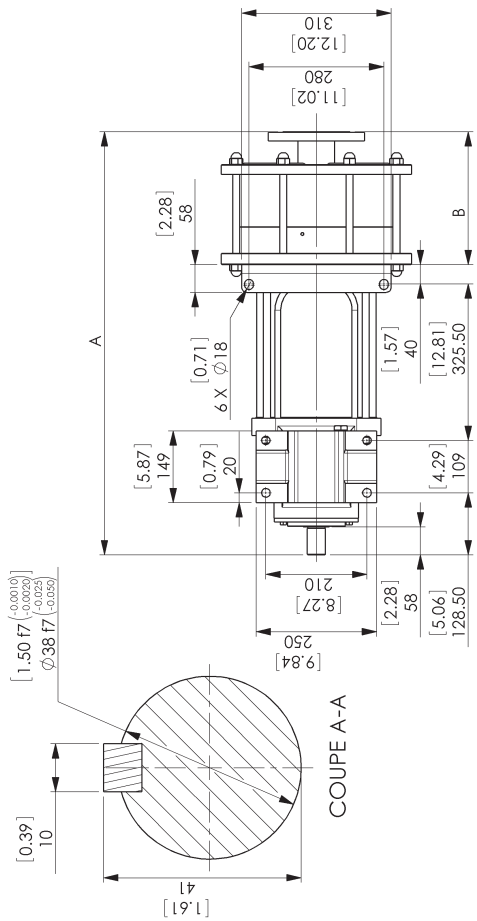
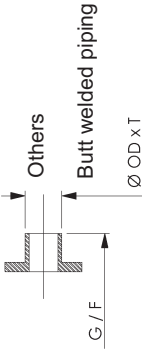

<b>A</b>	Lifting ring
<b>P</b>	Pump plate
<b>R</b>	Filling / Breather
<b>V</b>	Draining
<b>N</b>	Oil level

DN	C24i / C36i	A	B	C	ØD	E	F	G	ØOD x T	M (no unit)	ØL	ØK	ØB1	Weight
80	C24i	879	276	533.5	200	187	207	553.5	- x -	8	18	160	90.5	185
		[34.606]	[10.866]	[21.004]	[7.874]	[7.362]	[8.15]	[21.791]	- x -	-	[0.709]	[6.299]	[3.563]	[408]
80	C36i	905.5	302.5	560	200	187	207	560	- x -	8	18	160	90.5	200
		[35.65]	[11.909]	[22.047]	[7.874]	[7.362]	[8.15]	[22.835]	- x -	-	[0.709]	[6.299]	[3.563]	[441]
80	C24i	879	276	533.5	190	187	217	563.5	- x -	4	18	162.5	90.5	185
		[34.606]	[10.866]	[21.004]	[7.48]	[7.362]	[8.543]	[22.185]	- x -	-	[0.709]	[6.004]	[3.563]	[408]
80	C36i	905.5	302.5	560	190	187	217	590	- x -	4	18	162.5	90.5	200
		[35.65]	[11.909]	[22.047]	[7.48]	[7.362]	[8.543]	[23.228]	- x -	-	[0.709]	[6.004]	[3.563]	[441]
80	C24i	874	271	528.5	165	162	246	592.5	85 x 2.00	6	13	125	-	185
		[34.409]	[10.669]	[20.807]	[6.102]	[7.165]	[9.685]	[23.327]	[3.346 x 0.079]	-	[0.512]	[4.921]	-	[408]
80	C36i	900.5	297.5	555	165	162	246	619	85 x 2.00	8	13	125	-	200
		[35.453]	[11.713]	[21.85]	[6.102]	[7.165]	[9.685]	[24.37]	[3.346 x 0.079]	-	[0.512]	[4.921]	-	[441]
80	C24i	879	276	533.5	133	187	214.5	561	76.1 x 2.00	8	11	112	-	185
		[34.606]	[10.866]	[21.004]	[5.236]	[7.362]	[8.445]	[22.087]	[2.996 x 0.079]	-	[0.433]	[4.409]	-	[408]
80	C36i	905.5	302.5	560	133	187	214.5	577.5	76.1 x 2.00	8	11	112	-	200
		[35.65]	[11.909]	[22.047]	[5.236]	[7.362]	[8.445]	[22.736]	[2.996 x 0.079]	-	[0.433]	[4.409]	-	[441]

Connect S<sup>®</sup> is a registered trademark owned by NEUMO.

# C24 i - C36 i

with heating jacket

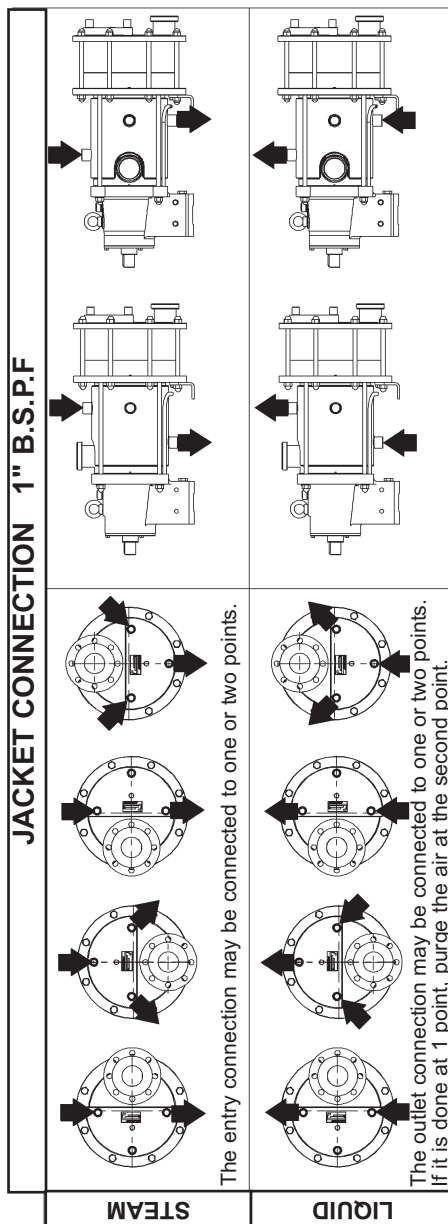
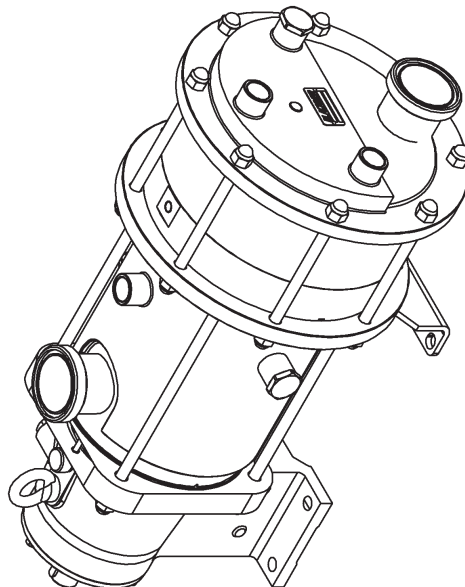
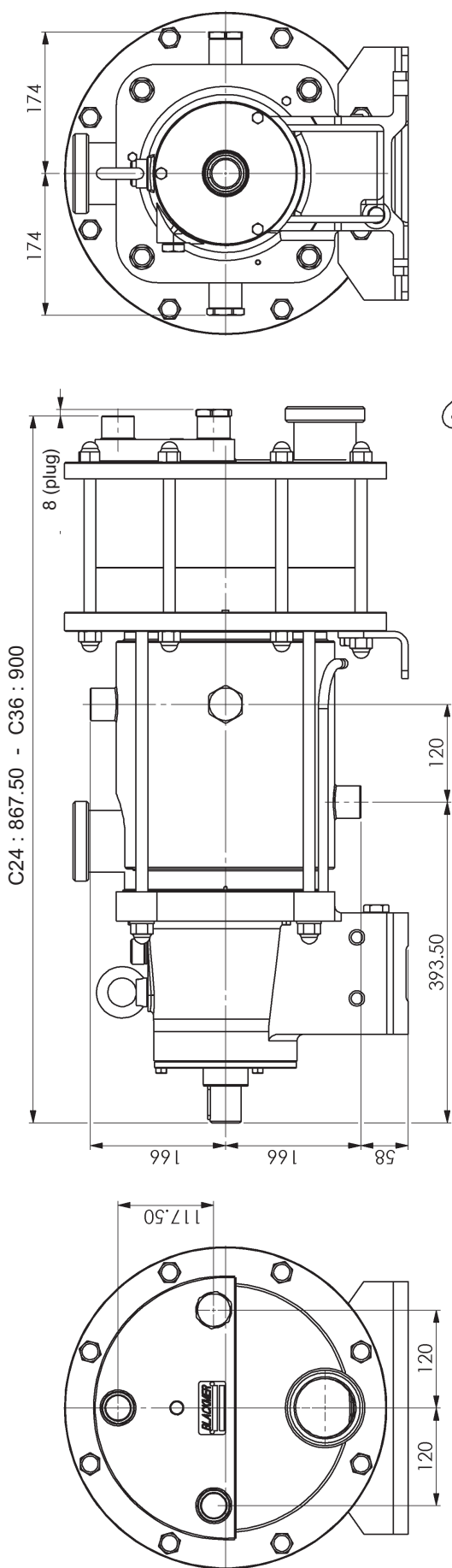

**NOTE :**

For the other sides, see the specific overall dimension plan for the connection.

Maximum jacket pressure : 8 bar (116 psi)

Maximum jacket temperature : FKM and FEP encapsulated FKM seals : 180°C.

**CAUTION :**

The pumped product must not exceed the maximum temperature of the pump.

**FOR ATEX PUMPS, SEE INSTRUCTIONS NR 1050.**

## 1. OVERALL DIMENSIONS (continued)

# Bellows monitoring system C24 - C36

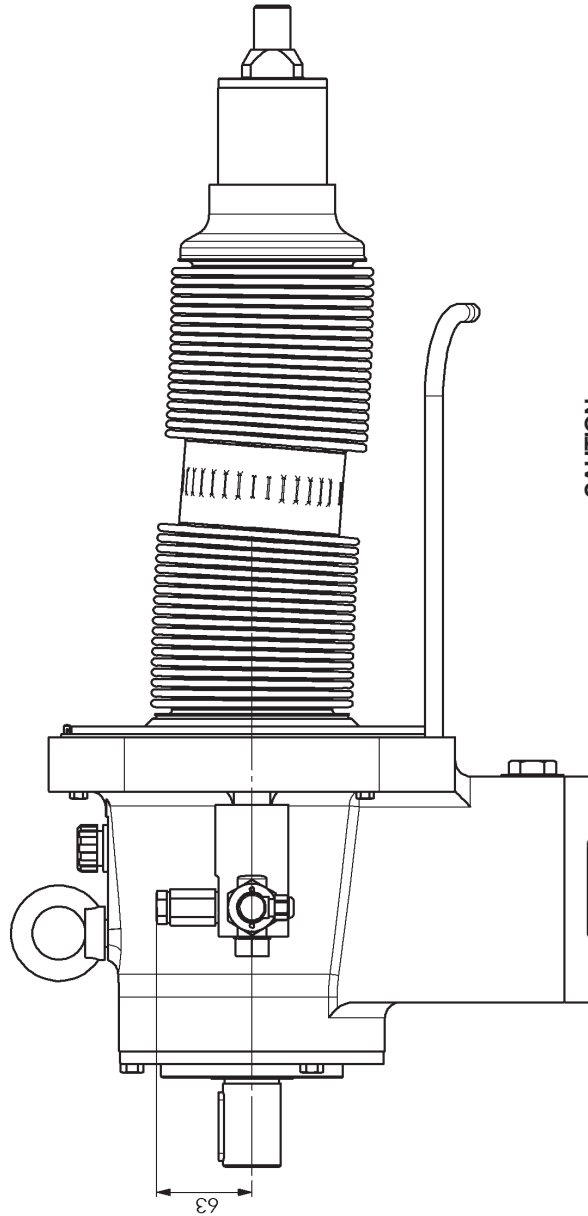
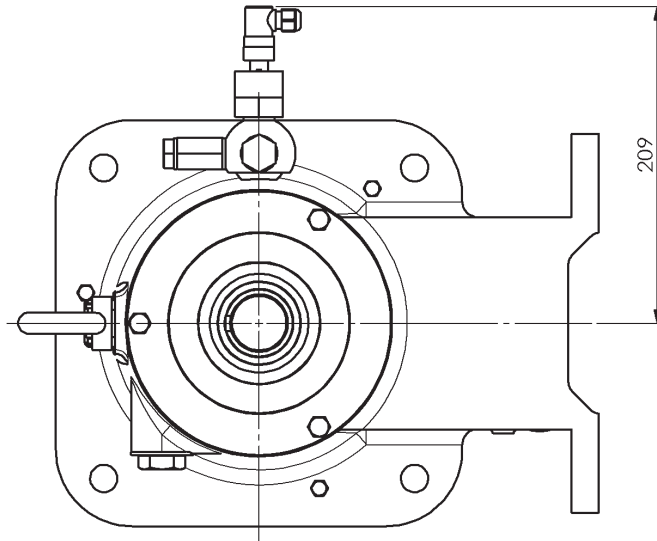

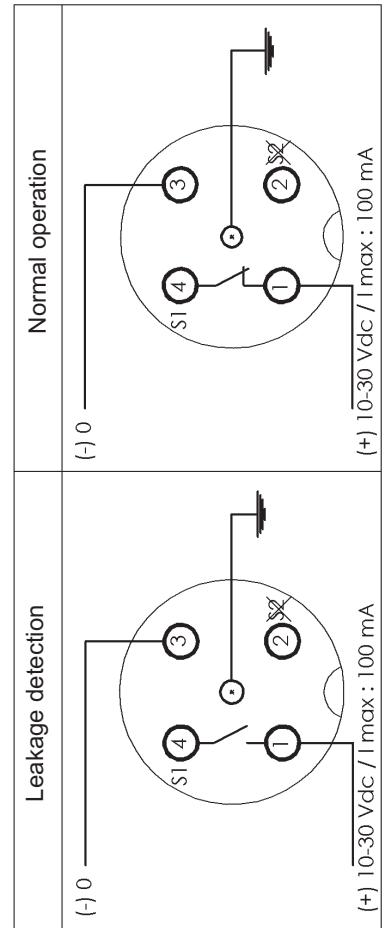

**CAUTION :**  
A BAD CONNECTION CAN DESTROY THE SENSOR.

**Wiring diagramm**  
Connector  
Do not use S2

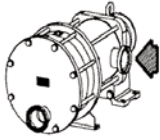
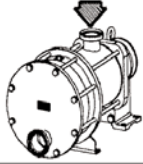
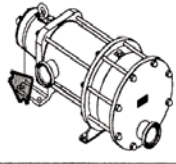
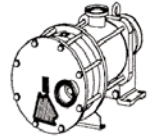
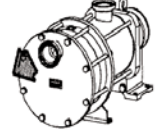
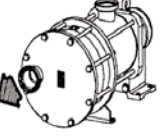

**NOTA :**  
Setting of detection levels is done in factory and do not have to be modified.  
For other dimensions, report to pump dimensional drawing.  
The dismantling of the transmission could be done only in factory.

## 2. INSTALLATION

POSSIBLE POSITIONS				
SUCTION	1 	2 STANDARD 	3 	
DISCHARGE	1 	2 	3 	4 STANDARD 

The C Series pump is a selfpriming volumetric PD pump.

Therefore, the pump must not run on a circuit with a closed valve. This is valid both for the suction circuit and for the discharge circuit.

### 2.1 ORIENTATION OF THE PUMP PORTS

The suction and discharge ports may be oriented in various positions.

If the ports positions needs to be changed at any time, see the corresponding paragraph.

#### NOTICE

**C-Series pumps remains drainable whatever position is chosen for the inlet port, but the outlet port must be at the bottom (position 4) to keep the self-draining capability.**

### 2.2 DIRECTION OF ROTATION

An arrow situated on the bearing housing indicates the correct direction of rotation.



When looking at the shaft, the rotation will be clockwise. When looking at the front cover, the direction of rotation will be anti-clockwise.

Verification of the correct rotation direction : Turn the pump the wrong way is not dangerous for the pump.

### 2.3 PROTECTION OF THE PUMP INSTALLATION

- For ease of maintenance, it is a good idea to place isolation valves before and after the pump. The sizing of these valves must correspond to the diameter of the pipes.
- Before any start-up, during operation or complete stopping of the pump, make sure the valves are open.
- During stop periods, with the pump full of product, either the suction or discharge circuit must be left open to enable expansion or contraction of the pumped product through reheating or cooling. If this instruction is not complied with, The bellows may be damaged and lead to premate failure.
- The bearing must be ventilate at all times, therefore the breather mounted on the bearing must be re-used. Never put the bung on.
- In case of flooded suction, it is possible to install a liquid detector in the place of the transmission breather (see § OPTIONS). This detector will enable the user to be informed in the case of failure of the bellows. In the case of detection, the installer must make sure the pump is stopped and the isolating valves are closed. Non compliance with this instruction can lead to the pumped product being spilt outside the pump.
- It is possible to have a puncture detection system with double-walled bellows : an inert gas is maintained under pressure between the 2 walls and said pressure is permanently monitored. A signal is dispatched immediately should a wall become punctured (see § OPTIONS).
- The stop time may lead to cooling of the product in the pump and therefore to an increase in viscosity. If this is the case, we recommend re-starting the pump at a speed adapted to this new viscosity (starting pump). Once the product arrives in the pump at the installation definition temperature, the pump may run at the speed specified for this application.

## 2. INSTALLATION (continued)

- Protection against excess pressure :

The pump must be protected against excess pressure. It can be delivered with a pressure switch to carry out this function.

If protection is provided by a control valve, check that the system does not generate excess pressure at the bellows (particularly if there are water hammers). Operating in this way will damage the bellows and shorten their lifetime.

<b>⚠ CAUTION</b>

Hazardous pressure can cause personal injury or property damage.

INCORRECT SETTINGS OF THE PRESSURE RELIEF VALVE CAN CAUSE PUMP COMPONENT FAILURE, PERSONAL INJURY, AND PROPERTY DAMAGE.

<b>⚠ CAUTION</b>

Hazardous pressure can cause personal injury or property damage.

FAILURE TO INSTALL ADEQUATELY SIZED PRESSURE RELIEF VALVE(S) CAN CAUSE PROPERTY DAMAGE, PERSONAL INJURY OR DEATH.

<b>⚠ CAUTION</b>

Hazardous pressure can cause personal injury or property damage.

PUMPS OPERATING AGAINST A CLOSED VALVE CAN CAUSE SYSTEM FAILURE, PERSONAL INJURY AND PROPERTY DAMAGE.

- Protection against foreign bodies :

The pump and the installation must also be protected against any risk of damage through the passage of foreign bodies by mounting a pre-filter at the pump suction.

In the case of foreseeable clogging of the pre-filter, we recommend using a vacuum switch to inform the user of pre-filter clogging. Prolonged running under cavitation may damage the pump.

### 2.4 HOISTING DEVICES

Put a sling in the lifting ring of the transmission and another under the pump cylinder.

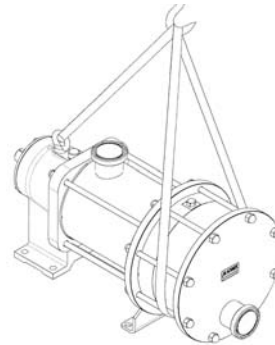

### 2.5 UNIT ASSEMBLY

The following instructions apply to pumps delivered with a bare shaft or for MOUVEX motor-driven pump units (if the latter have no specific instruction notice).

#### 2.5.1 INSTALLATION OF UNITS

<b>⚠ WARNING</b>

The weight of the parts can be dangerous and may provoke bodily injuries or material damages.

BE CAREFUL WITH THE WEIGHT OF THE PARTS WHEN THEY ARE BEING REMOVED.

<b>⚠ WARNING</b>

Dangerous voltage. Can cause injury and death.

DISCONNECT THE ELECTRICITY SUPPLY BEFORE ANY MAINTENANCE OPERATION.

The base below the unit is fundamental to ensuring correct operation and long service life.

The unit's base must be flat, level and sufficiently resistant to absorb the stresses caused by the motor-driven pump unit without deformation (if it is made of concrete, it must comply with the BAEL 91 standard).

If the unit is fastened using securing lugs or bolts, it must be carefully wedged to avoid deforming the frame while the bolts are tightened. A deformed frame would apply damaging stresses on the pump and the drive mechanism and misalign the coupling, causing vibrations, noise and premature wear. Ensure that the frame is well above the floor, except from the support plates.

## 2. INSTALLATION (continued)

If the unit is to be used in a food environment, support plates that allow the unit to be lifted for easier cleaning are recommended.

Allow, if possible, a clear space of approximately 50 cm on each side of the motor-driven pump unit (overall dimensions) to facilitate cleaning and give access if necessary to the pump, reduction gear and motor fastening nuts. In all cases, the dimensions around the motor-driven pump unit must be designed to give the space required for dismantling the pump (if the need arises, use the values given on the overall dimension drawing).

For staff and equipment protection, the frame includes a ground connection point that should be used.

### 2.5.2 ALIGNMENT OF THE MOTOR/PUMP OR REDUCTION GEAR/PUMP SHAFTS

<b>⚠ WARNING</b>

<b>Do not operate without guard in place.</b>

IF OPERATED WITHOUT THE SHAFT GUARD, THERE IS CONSIDERABLE RISK OF SEVERE PERSONAL INJURY, SIGNIFICANT PROPERTY DAMAGE OR EVEN DEATH

<b>⚠ WARNING</b>

<b>Dangerous voltage. Can cause injury and death.</b>

DISCONNECT THE ELECTRICITY SUPPLY BEFORE ANY MAINTENANCE OPERATION.

**NEVER START A UNIT IF THE COUPLING ALIGNMENT IS INCORRECT. THIS IS A CONDITION OF OUR GUARANTEE.**

#### REMINDER :

Coupling must never be used to compensate for a misalignment.

To control the alignment between the coupling and the shaft, use a straight-edge for concentricity and thickness gauges for angular misalignment (see instructions of the coupling for authorised values).

The 3 figures below show in detail the operation and the possible defects :

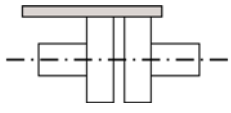
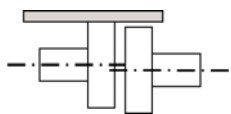
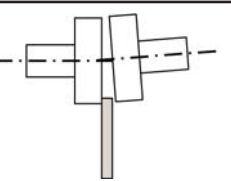
<i>Make this check for 4 points: up - down - left - right</i>	
	<i>Correct</i>
	<i>Out-of-parallelism</i>
	<i>Angular defect</i>

Controlling the alignment at each stage of the installation is important to be sure that none of these stages have generated stresses on the unit or the pump :

- after fastening on the foundations.
- after fastening the pipes.
- after the pump has been operated at the normal operating temperature.

Where the pumps are supplied assembled as a unit, the motor and pump shafts have been perfectly aligned in the factory before delivery, but they must be systematically controlled on acceptance at the site and realigned if necessary.

To do this, do not modify the wedging of the various parts, but check the flatness of the support surface and use the adjustable foot to clear the frame of stresses that could affect it.

### 2.5.3 ELECTIC MOTORS

<b>⚠ WARNING</b>

<b>Dangerous voltage. Can cause injury and death.</b>

DISCONNECT THE ELECTRICITY SUPPLY BEFORE ANY MAINTENANCE OPERATION.

Check the compatibility of the instructions on the motor with the supply voltage.

Follow the wiring diagram, use wiring that is appropriate for the power and be particularly careful about the contacts which must be well tightened.

The motors should be protected with circuit breakers and suitable fuses. Connect the regulatory electrical grounding.

## 2. INSTALLATION (continued)

### 2.5.4 THERMIC MOTORS



THE SURFACES CAN BE AT A TEMPERATURE LIABLE TO CAUSE INJURY OR SEVERE DAMAGE.

Do not forget that these motors are not reversible. It is absolutely necessary to carefully control the suction and discharge sides of the pump before connecting the group to the piping.

Using electric motors is very common now; however, we strongly advise careful reading of the accompanying instruction manual.

### 2.5.5 CONTROL OF THE SENSE OF ROTATION



TAKE ALL NECESSARY MEASURES TO RENDER ANY START-UP, EVEN ACCIDENTAL, OF THE PUMP DURING THE WORK IMPOSSIBLE.

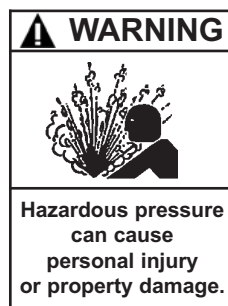

IT IS IMPERATIVE THAT THE HYDRAULIC PRESSURE IS RELEASED BEFORE EACH MAINTENANCE OPERATION TO AVOID PERSONAL INJURY OR MATERIAL DAMAGE

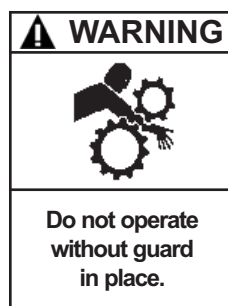

A DRIVE SHAFT GUARD BETWEEN THE PTO AND PUMP MUST BE PROVIDED TO PREVENT PERSONAL INJURY, PROPERTY DAMAGE, OR DEATH.

This control needs to be done with no liquid pumped through the pump, and both the suction and discharge circuits venting to avoid generating unexpected pressure (at the suction side, for example). This will ensure that the control will not damage either the pump or the installation.

Start the pump empty to check that the connections are good and that the direction of rotation corresponds to the suction and discharge direction on the installation. If it is necessary to reverse the direction of rotation, follow the instructions below :

Three-phase motor : switch any 2 current input wires.

Bi-phase motor : switch two same phase wires.

Single-phase motor : follow the instructions on the notice supplied with the motor.

## 3. UTILISATION

### 3.1 NOISE LEVEL

The sound level of a pump is greatly influenced by its conditions of use. Cavitation and pumping products with high gas contents generally increases the sound level.

Under the following pumping conditions :

- excluding cavitation
- discharge pressure :
  - C24 : . . . . . 9 bar (130,5 psi)
  - C36 : . . . . . 6 bar (87 psi)
- speed of rotation 450 rpm
- water product or equivalent

The sound level reached for the C24 / C36 pump in good conditions without the drive is less than 83 dB(A).

### 3.2 COMMISSIONING

Make sure that the circuit valves are open before starting the pump.

To avoid any risk of polluting the product to be pumped, rinse the whole installation before starting-up so as to eliminate any contaminants that may remain in the piping, tanks etc. at the time of installation.

### 3.3 DRY RUNNING

The C series pump is self priming and is capable of emptying the pipes. To do this, it can run dry for a maximum duration of 5 minutes.

### 3.4 PUMP STOP

So as not to damage the pump, make sure that the pump is completely stopped before closing the valves.

## 4. CLEAN IN PLACE (CIP) & STERILISATION IN PLACE (SIP)

### 4.1 GENERAL

On-site cleaning (CIP) of an installation is undertaken by circulating various cleaning solutions through the equipment parts.

An automated CIP system enables :

- Preparation of the appropriate concentrations for the different cleaning solutions.
- Re-heating of certain cleaning solutions at the optimum temperature.
- Circulation of the different solutions through the equipment parts to be cleaned.
- Rinsing and drying of the equipment parts.

For the most part, automated CIP systems are an integral part of process equipments.

Before starting CIP and if the process has not been followed by a water flush, care must be taken that a minimum of residual products remains in the piping and in the pump. The C Series pumps, thanks to their excellent suction and compression capabilities, enable reducing the quantities of residual products. This minimises loss of products, eases cleaning and reduces cycle times.

The C Series pumps are perfectly adapted to all processes necessitating CIP. C-Series pumps are 3-A marked units and have been successfully tested for in-place cleanability according to EHEDG document n°2. By complying with the installation rules described above, these pumps will give you entire satisfaction for a long time.

The start of CIP must immediately follow the end of the process to avoid any clogging or untimely drying.



**AT NO TIME MAY THE C SERIES OFFSET PLUNGER PUMPS BE USED AS CIP PUMPS.**

Non-compliance with this instruction may lead to rapid wear of cylinder and piston.

### 4.2 CIP CIRCUIT RECOMMENDED

In all cases, the pressure at the pump inlet during cleaning must not exceed 3 bar (43,5 psi).

The flow through the pump required for optimal cleaning is **40 - 45 m<sup>3</sup>/h**.

This flow corresponds to difficult cleaning (sticky and viscous products). It can be reduced for easier types of cleaning.

### 4.3 PUMPS ARRANGED IN SERIES

**This type of assembly is preferred in all cases.** It ensures optimal cleaning for the pump and makes use of the special design of the C Series, i.e. the possibility of lifting the piston with the cleaning product.

As the pressure at the pump inlet is higher than that at its outlet, the piston lifts from the cylinder and permits the passage of all the cleaning liquid through the C Series pump.

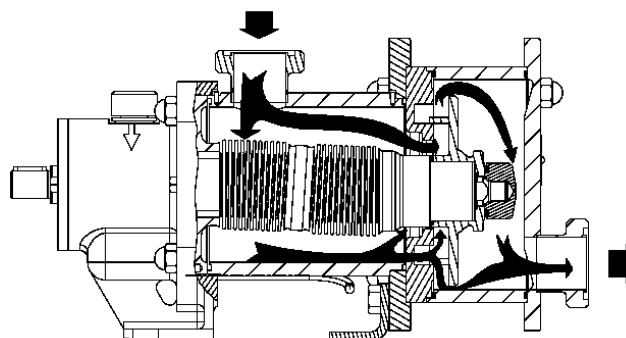

- A centrifuge pump is used for CIP cycles. This pump is placed upstream of the C Series pump.

The centrifuge pump must be installed in series with the C Series pump.

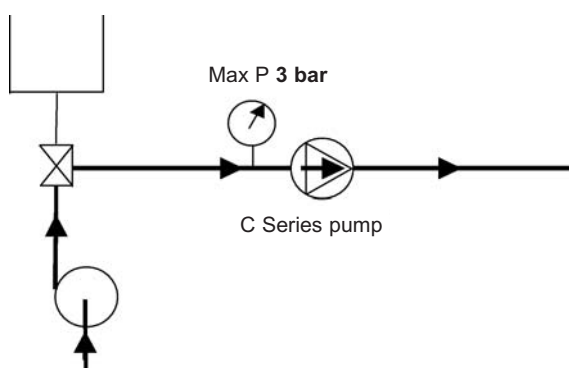

It is preferable not to run the C Series pump during CIP although low speed (< 100 rpm) is acceptable by alternating start/stop operation.

- In certain cases, the flow of the cleaning liquid required for the installation is higher than that recommended for cleaning the pump. In this case, a bypass must be used.

The bypass valve is adjusted to divide the flow between the circuit flowing through the C Series pump and the bypass circuit.

## 4. CLEAN IN PLACE (CIP) & STERILISATION IN PLACE (SIP) (continued)

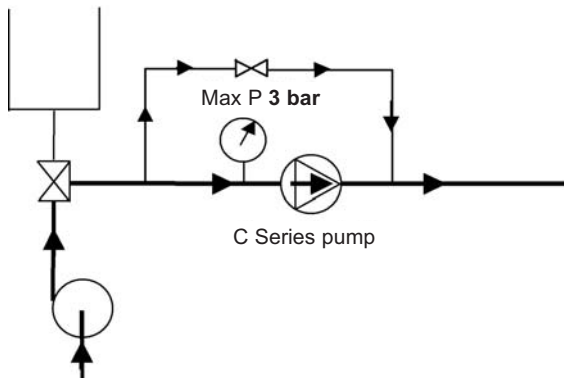

It is preferable not to run the C Series pump during CIP, although low speed (< 100 rpm) is acceptable by alternating start/stop operation.

- In certain cases, the cleaning pressure required for the installation is higher than 3 bar (43,5 psi). In this case, the use of a bypass is required and cleaning is done in 2 steps.

### Cleaning the pump :

The cleaning flow should be limited during the cleaning of the C pump to ensure a maximum pressure of 3 bar (43,5 psi) at the C pump inlet.

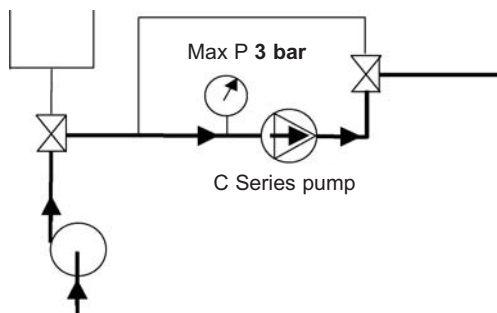

It is preferable not to run the C Series pump during CIP although low speed (< 100 rpm) is acceptable by alternating start/stop operation.

### Cleaning the installation :

During this operation, the valve system used must ensure that no flow can pass through the pump so that the C Series pump does not rotate. Under these conditions, with the pump completely stopped, the pressure of the washing circuit can rise up to 6 bar (87 psi).

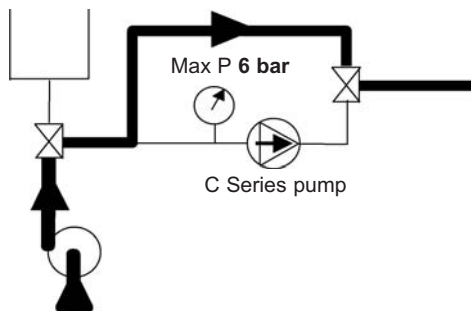

The pump must not run during this operation.

### 4.4 PUMPS ARRANGED IN PARALLEL

For applications where cleaning is easy and the differential pressure of, the C Series pump is lower than 2 bar (29 psi) during this operation, assembly in parallel is authorised. It should be noted that during cleaning, the C Series pump will be acting on a product with generally few lubricating properties. This will contribute towards wear of the pump.

The CIP centrifuge pump must never be installed in parallel with a C Series pump without taking special precautions.

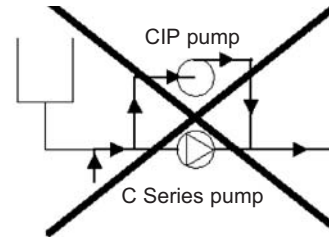

Indeed, in this case, the pressure at the inlet of the C Series pump is lower than the pressure at the discharge and the piston remains forced against the cylinder. Therefore, there the C Series pump no longer provides a passage. Its efficient cleaning can no longer be ensured and the cylinder/piston pair will become prematurely worn.

### Authorised assembly :

As mentioned previously for applications where cleaning is easy, assembly in parallel is authorised when the valves are installed so that the cleaning pressure of the circuit does not come into contact with the C Series pump.

In this case, the C Series pump cleans itself.

### Cleaning the pump :

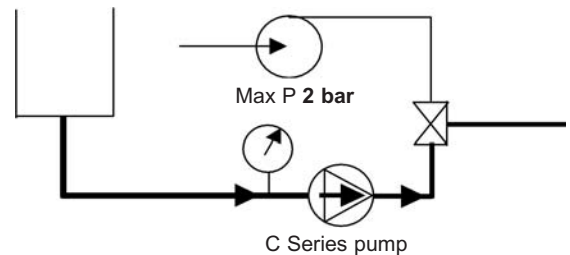

We recommend limiting the rotation speed of the C Series pump.

### Cleaning the installation :

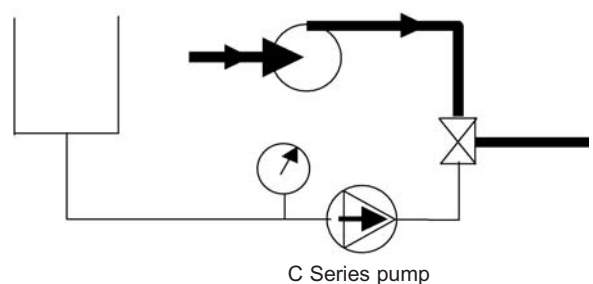

The C Series pump is stopped when cleaning the installation.

---

## 4. CLEAN IN PLACE (CIP) & STERILISATION IN PLACE (SIP)(continued)

### 4.5 SUCCESSIVE CYCLES

Generally, the most efficient CIPs comprise 5 stages :

#### 1. Pre-washing with clean water

Water at room temperature. 10 to 15 minute cycle. This pre-wash enables evacuation of the remaining residues.

#### 2. Washing with an alkaline detergent

Typically this is soda at 2,5% at a temperature of 80°C. 20 to 30 minute cycle. This wash particularly enables dissolving and evacuating grease and proteins.

#### 3. Rinsing with clean water

Water at room temperature. 10 minute cycle. This rinse enables avoiding the mixture of 2 cleaning solutions.

#### 4. Washing with an acid solution

Typically this is nitric acid at 2,5% at room temperature. 10 to 15 minute cycle. This wash particularly enables dissolving and evacuating proteins and inorganic salts.

#### 5. Rinsing with clean water

Water at room temperature. Several 1 to 2 minute cycles. These rinses enable evacuating all traces of acid solution.

During all these CIP stages, the average speeds of the cleaning liquids in the pipes must be between 1,5 and 3 m/s.

### 4.6 STERILISATION IN PLACE (SIP)

The serie C pumps are perfectly adapted to all processes using SIP (Sterilisation In Place) : pump stopped / maximum 20 mn per cycle / 1 or 2 cycles per day.

---

## 5. MAINTENANCE

### 5.1 NECESSARY TOOLS

- 24 Socket wrench
- 13-32 Open-end spanner
- Hub puller
- 85 Open-end spanner or Monkey wrench

Tightened torques :

- M8 : 18 Nm
- M16 : 100 Nm
- M24 : 200 Nm

## 6. OPENING OF THE PUMP

**⚠ WARNING**



Any unforeseen start-up can cause serious injuries or important material damages.

TAKE ALL NECESSARY MEASURES TO RENDER ANY START-UP, EVEN ACCIDENTAL, OF THE PUMP DURING THE WORK IMPOSSIBLE.

**⚠ WARNING**



Hazardous pressure can cause personal injury or property damage.

DISCONNECTING THE FLUID OR PRESSURE CONTAINMENT COMPONENTS DURING PUMP OPERATION CAN CAUSE SERIOUS PERSONAL INJURY, DEATH OR MAJOR PROPERTY DAMAGE.

**⚠ CAUTION**



Hazardous pressure can cause personal injury or property damage.

FAILURE TO RELIEVE SYSTEM PRESSURE PRIOR TO PERFORMING PUMP SERVICE OR MAINTENANCE CAN CAUSE PERSONAL INJURY OR PROPERTY DAMAGE.

**⚠ WARNING**



Hazardous or toxic fluids can cause serious injury.

IF PUMPING HAZARDOUS OR TOXIC FLUIDS, THE SYSTEM MUST BE FLUSHED PRIOR TO PERFORMING ANY SERVICE OPERATION.

**⚠ WARNING**



The weight of the parts can be dangerous and may provoke bodily injuries or material damages.

BE CAREFUL WITH THE WEIGHT OF THE PARTS WHEN THEY ARE BEING REMOVED.

**⚠ CAUTION**



Slippery lubricant. Spills should be cleaned up.

THE PUMP LUBRICANT IS VERY SLIPPERY AND MAY CAUSE SERIOUS INJURY. ANY SPILLS MUST BE CLEANED UP.

### 6.1 ASSEMBLY / DISMANTLING

Before any dismantling, make sure that the pump has been drained and take the necessary measures to avoid starting-up. No start-up, even accidental, must be allowed.

- Disconnect the pump from the discharge pipe.
- Unscrew the 8 nuts **106** and remove the 8 tierods **105** and **107**.

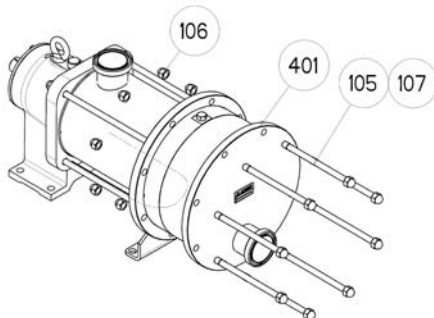

- Remove the front cover **401**. If the discharge piping is mounted in a rigid manner, pivot the bottom **401** so as to free the connection.

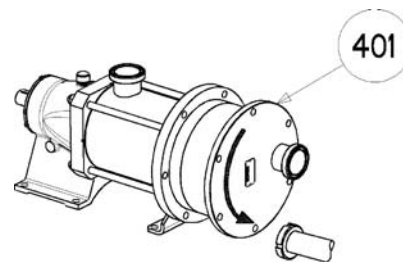

- Remove the outlet tube **402** and its seals **205**.

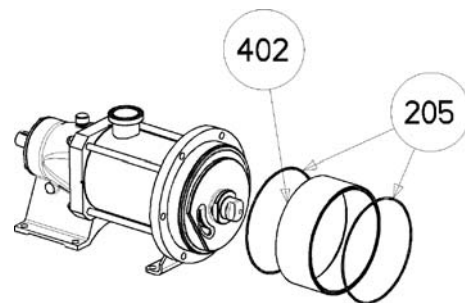

## 6. OPENING OF THE PUMP (continued)

- Hold the piston **301** with a 85 Open-end spanner or a monkey wrench and unscrew the nut **304** and its seal **305**.

**It is important to keep a good grip on the piston, its rotation could lead to deterioration of the bellows.**

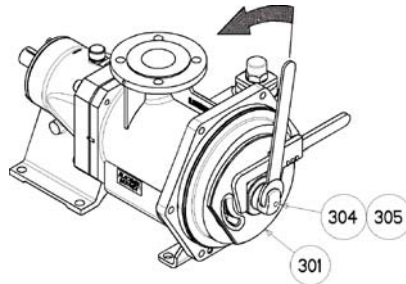

- To make handling of the cylinder/piston unit easier, move the lifting ring from the transmission body to the cylinder.

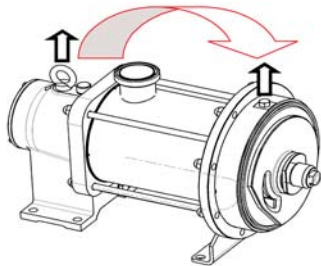

- Screw the lifting hook in the tapped hole of the cylinder, provided for this purpose and tighten the screw in the location of the lifting ring.

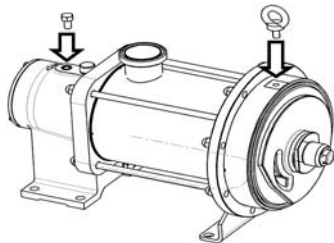

- With the help of a hub puller, extract the piston **301**.

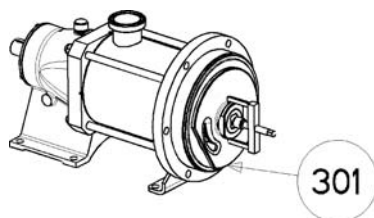

- Remove the cylinder **201** and the seals **113** and **306**.

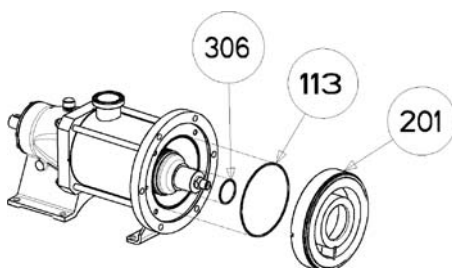

### 6.2 CHECKING OF PARTS

The piston **301** and the cylinder **201** are active parts (wearing parts) on which the pump's efficiency directly depends. It is therefore advisable to regularly check the pump's efficiency and replace the cylinder / piston if it decreases.

In addition, as using a cylinder / piston that is too worn may damage the pump's transmission system, it is advisable to replace the cylinder / piston if the maximum acceptable wear dimensions defined in the table below are reached.

MOUVEX offers its customers a "Standard Exchange" service, consisting of the repairing of worn parts, to allow parts to be reused without reducing the pump's efficiency.

In order to benefit from this service, the parts must be within the minimum wear dimensions for Standard Exchange defined in the table below :

		Piston <b>301</b> mm (inch)	Cylinder <b>201</b> mm (inch)
C24 i	New dimension	11 (0,433)	69 (2,717)
	Minimum wear dimension acceptable	8 (0,315)	66 (2,598)
	Minimum wear dimension for exchange unit	10 (0,394)	68 (2,677)
C36 i	New dimension	11 (0,433)	97,5 (2,839)
	Minimum wear dimension acceptable	8 (0,315)	94,5 (3,720)
	Minimum wear dimension for exchange unit	10 (0,394)	96,5 (3,799)

As changes in the pump's efficiency depend on the conditions of use (pressure, rotation speed, liquid pumped, etc.), MOUVEX recommends that users define the monitoring ranges and the preventive maintenance schedule according to their own experience.

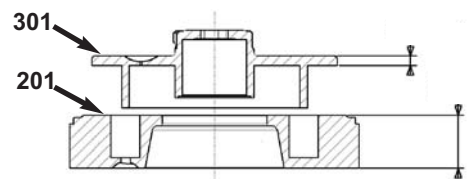

#### NOTICE

**When disassembling the piston nut 304, if the enclosed thread surfaces have become soiled, we recommend cleaning them as follows : clean the inner thread by washing, rinsing and sterilizing the whole part (i.e. with a steam sterilization), then remove any impurities from the external threads by washing with a brush followed by rinsing with a bactericide solution before reassembly.**

## 7. ASSEMBLY OF CYLINDER/PISTON

- Check the state of the seals **205**, **305**, **306**, **113** and replace them if necessary.

### NOTICE

Seals are designed for use in normal conditions intended for use in food process. In order to assure a perfect sealing on C series pumps we recommend to :

- do an inspection of the seals every three months (this time could be shorter if using the pump in hard conditions. Contact the manufacture for advice if necessary).
- replace the pump sealing every two years (refer to the § PROTECTION OF THE BELLOWS for the replacement of the second seal).

- Position the seal **113** on the large flange and the seal **306** on the hub.

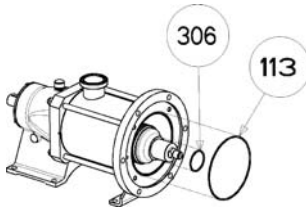

- Engage the piston **301** with the cylinder **201**, the slot of the piston being opposite the partition of the cylinder. Position the cylinder/piston unit **201/301** so that the recess of cylinder **201** faces positioning pin **118**.
- Engage the cylinder/piston unit **201/301** on hub **596** (to make work easier, position hub **596** upwards) then push home making sure that the oblong hole of the piston engages within the 2 flat surfaces of the end of the hub **596**.

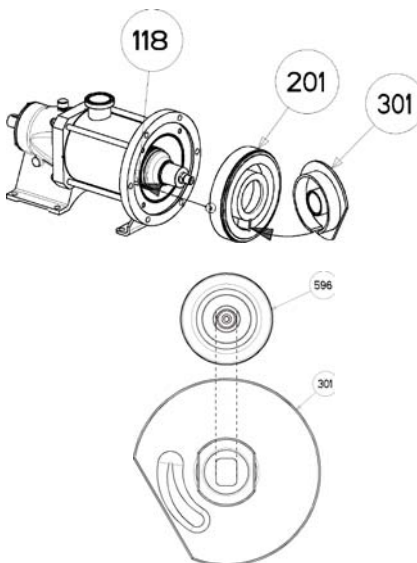

- Place thread locking adhesive (Loctite® 243\* or equivalent) on the thread of the transmission hub **596**.

### WARNING



The weight of the parts can be dangerous and may provoke bodily injuries or material damages.

BE CAREFUL WITH THE WEIGHT OF THE PARTS WHEN THEY ARE BEING REMOVED.

- Hold the piston **301** with a 85 Open-end spanner or a monkey wrench and screw-up the nut **304** after mounting the seal **305** on to the rear face (M24 : 200 Nm).

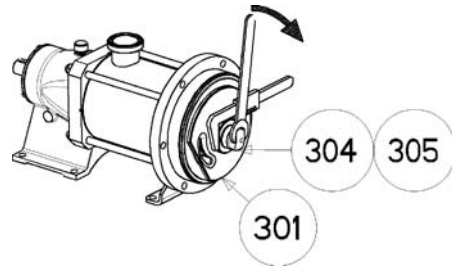
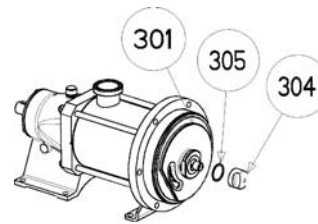

It is important to keep a good grip on the piston; its rotation could lead to deterioration of the bellows.

- Re-mount the outlet tube **402** with its 2 seals **205**.

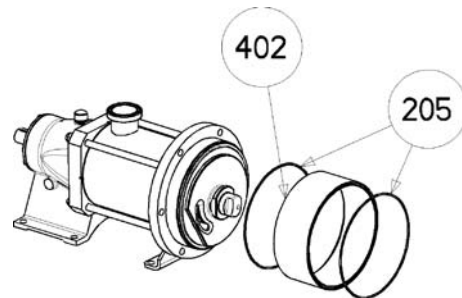

- Re-mount the front cover **401** while positioning the outlet port desired.
- Position the rods **107** and screw up the 8 nuts **106** (8 x M16 assembly torque 100 Nm).

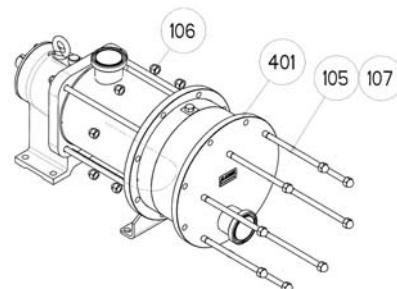

\* Loctite® is a registered trademark.

## 8. PROTECTION OF THE BELLOWS



**BE CAREFUL WITH THE WEIGHT OF THE PARTS WHEN THEY ARE BEING REMOVED.**

- Dismantle the cylinder/piston couple (see corresponding §).
- Remove the 2 fixing screws from the base frame of the lug **108**.
- On the drive side, remove the 4 nuts **115**.

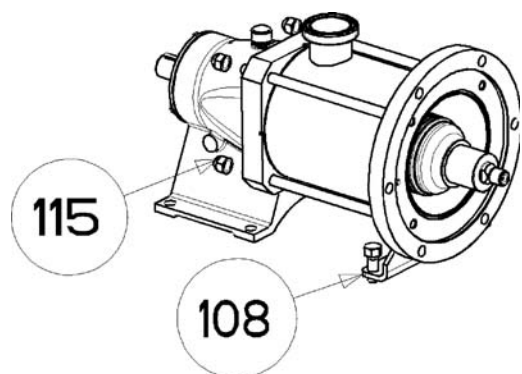

- With the help of a mallet, lightly tap the large flange **104** to free the tube **101** from the transmission hub **596**.
- Remove the tube **101** while taking care of impact.
- Remove the seal **113**.
- Inspect the bellows : any impact, scratch or distortion necessitates its replacement.

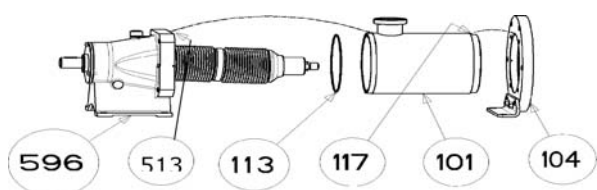

- Assembly is undertaken in the reverse order of dismantling, taking care to correctly position the seal **113** and the indexing pins **117** and **513**. The nuts **115** must be re-mounted with thread locking adhesive (Loctite® 243\* or equivalent) :

4 x M16 : Assembly torque 100 Nm.

Under preventive maintenance (every 135 millions of cycles duty) or in case of damage of the bellows, we suggest transmission exchange program.

In this case : The transmission delivered is equipped with a tubular foam protection. We advise leaving this protection around the bellows until re-mounting of the piston and cylinder.



**DO NOT FORGET TO REMOVE THE PROTECTION BEFORE MOUNTING THE CYLINDER.**

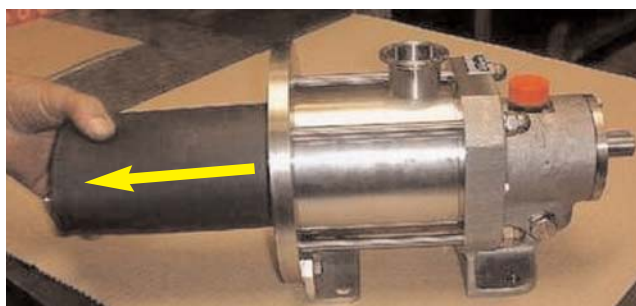

\* Loctite® is a registered trademark.

## 9. CHANGING THE LIP SEAL

### CAUTION



THE PUMP LUBRICANT IS VERY SLIPPERY AND MAY CAUSE SERIOUS INJURY. ANY SPILLS MUST BE CLEANED UP.

Slippery lubricant.  
Spills should be cleaned up.

- Drain the pump bearing (see corresponding §).
- Unscrew the 3 screws **609**.
- Remove the cover **607** and the seal **602**.

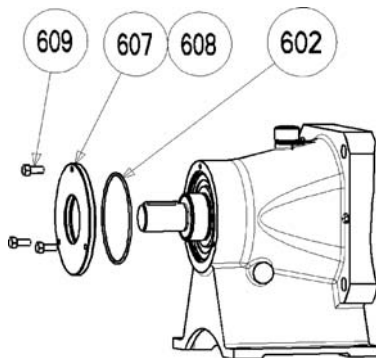

- Extract the 2 lip seals **608**.
- Fit 2 new seals **608**, one on each side of the cover, lip directed towards the interior of the transmission.

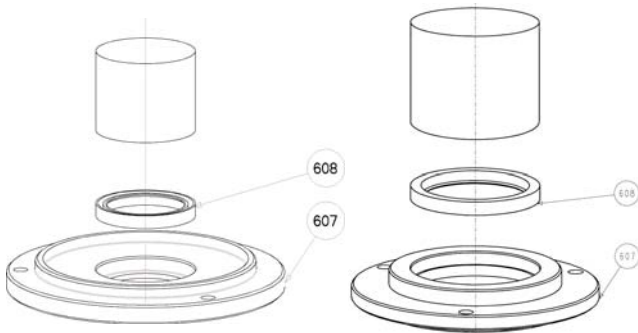

- If the seal face is marked, change the ring **507**. Break the ring with a chisel then fit a new ring after heating it at 90°C (in an oil bath or at HF).

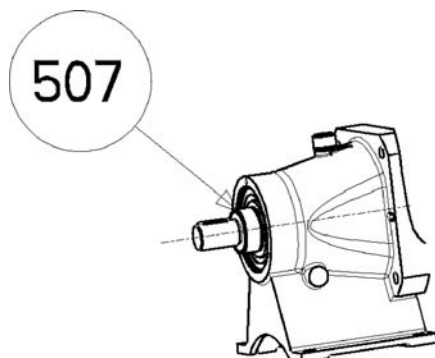

- Re-mount the cover **607** after placing the seal **602**, greasing the lips of the seals and greasing between the 2 seals **608**.



**FOOD SYNTHETIC GREASE :**  
Compulsory reference because compatible with the standard MOUVEX bearing oil.

- After replacing the drain bung, fill the bearing with 4,5 litres of oil\* (see § DRAINING OF BEARING).
- Screw back the breather **715**.

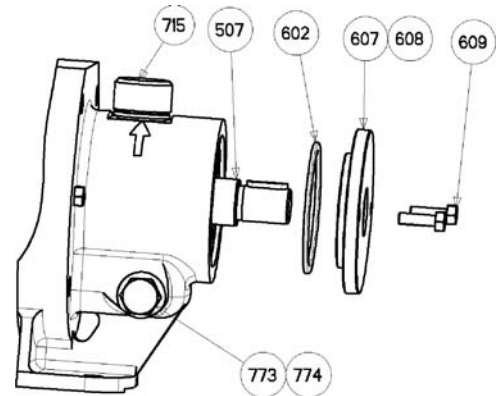

\* Standard oil provided by MOUVEX : CS05 Food synthetic oil (Safety data sheet is supplied with the new pump and on inquiry).

\* Other oil provided by customer.

## 10. CHANGING THE ORIENTATION OF THE PORTS

### ⚠ WARNING



The weight of the parts can be dangerous and may provoke bodily injuries or material damages.

BE CAREFUL WITH THE WEIGHT OF THE PARTS WHEN THEY ARE BEING REMOVED.

### 10.1 DISCHARGE PORT

- Unscrew the 8 nuts **106** and remove the 8 rods **107**.
- Turn the front cover **401** so as to position the outlet port in the desired position.
- Replace the 8 rods **107** and tighten the nuts **106**.
- Make sure that the seal **205** is secured in its housing. Secure it with a grease that is compatible with the transferred product if necessary.

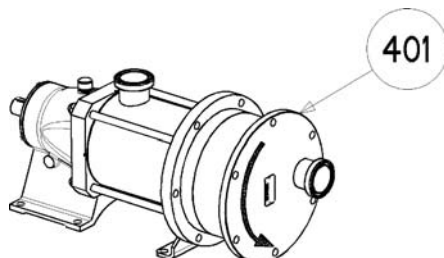
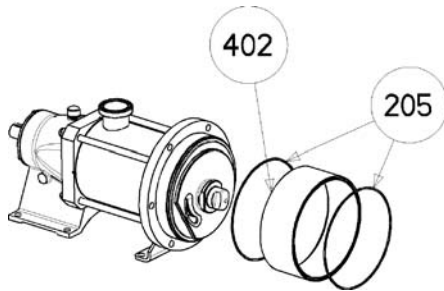
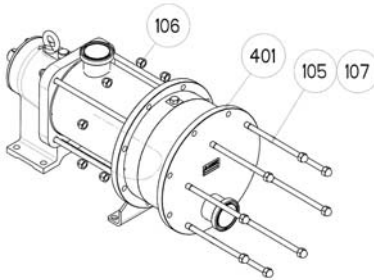

### 10.2 SUCTION PORT

- Dismantle the main body **101** including the suction port as indicated in the corresponding §.
- Re-mount the main body **101** in the desired position by fitting the indexing pins in the housings provided in the bearing **596** and the flange **104**.
- Make sure that the seal **113** is secured in its housing. Secure it with a grease that is compatible with the transferred product if necessary.

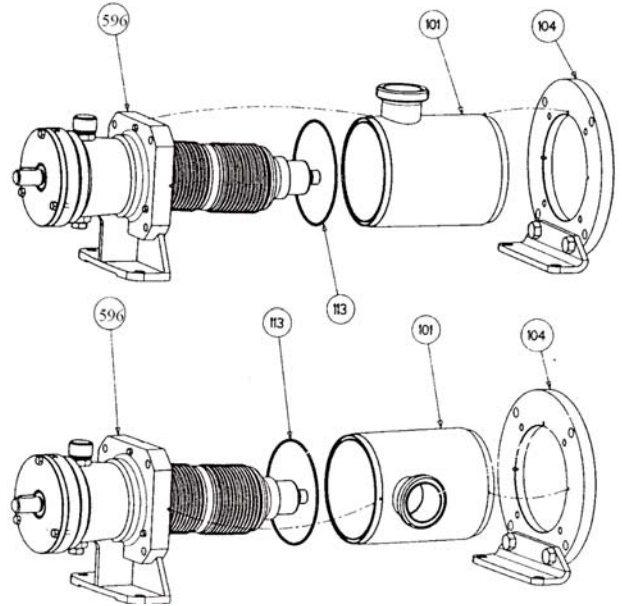

## 11. DRAINING OF BEARING

### CAUTION



Slippery lubricant.  
Spills should be  
cleaned up.

THE PUMP LUBRICANT IS VERY SLIPPERY AND MAY CAUSE SERIOUS INJURY. ANY SPILLS MUST BE CLEANED UP.

- Screw back the breather 715.

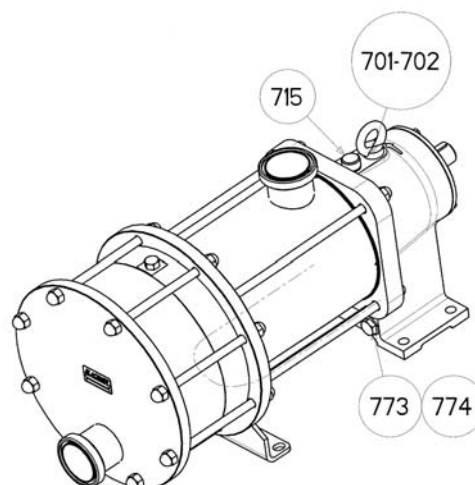

- Drain the transmission following the board below :

- **Data with standard MOUVEX oil :**

Temperature of product pumped / heating product	Draining interval (running hours)
$80\text{ °C} < T \leq 100\text{ °C}$	12 000
$T \leq 80\text{ °C}$	24 000

- **Data with other customer oil :** the drawing interval is defined by the customer (tests results) regarding the oil specifications and the pump conditions.

- Drain the pump by removing the drain bung with its seal **773-774** and the breather **715**.
- Replace the drain bung and its seal.
- Fill the transmission with 4,5 litres of oil\*.
- Check oil level that the level is between 1 and 5 mm above the schaft.

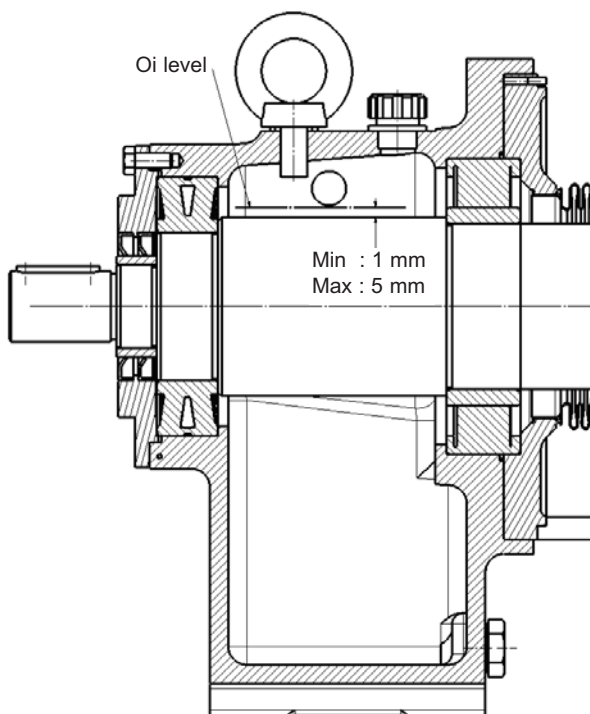

\* Standard oil provided by MOUVEX : CS05 Food synthetic oil (Safety data sheet is supplied with the new pump and on inquiry).

\* Other oil provided by customer.

## 12. OPTIONS

### 12.1 LIQUID DETECTOR

The liquid detector works with single and double ply bellows. It is installed on the vent circuit (see § PROTECTION OF THE PUMP INSTALLATION).

In case of flooded suction or during the cleaning process, a bellows puncture will fill the transmission with liquid. The liquid detector will inform the user when a bellows puncture occurs.

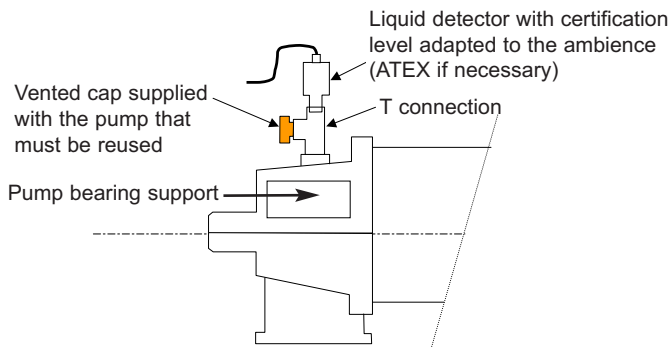

### 12.2 BELLOWS MONITORING SYSTEM

The bellows monitoring system called (BMS) works only with double ply bellows.

Working principle : During the transmission assembly, a gas pressure (argon) is introduced in between the bellows ply. A pressure switch is connected on the bellows's gas filling cavity and all the circuit is sealed.

The gas pressure is 0,6 bar (87 psi) above the maximum acceptable pressure on the bellows under working condition.

Any puncture in either one of the two metallic bellows leads to a pressure drop. When the pressure decreases under the pressure switch setting, it cuts the electrical circuit.

To connect the pressure switch, follow the manufacturer's instruction.