

(See Instructions 1001-D00 for Installation, Operation and Maintenance)

Section	1001
Effective	April 2009
Replaces	May 2007

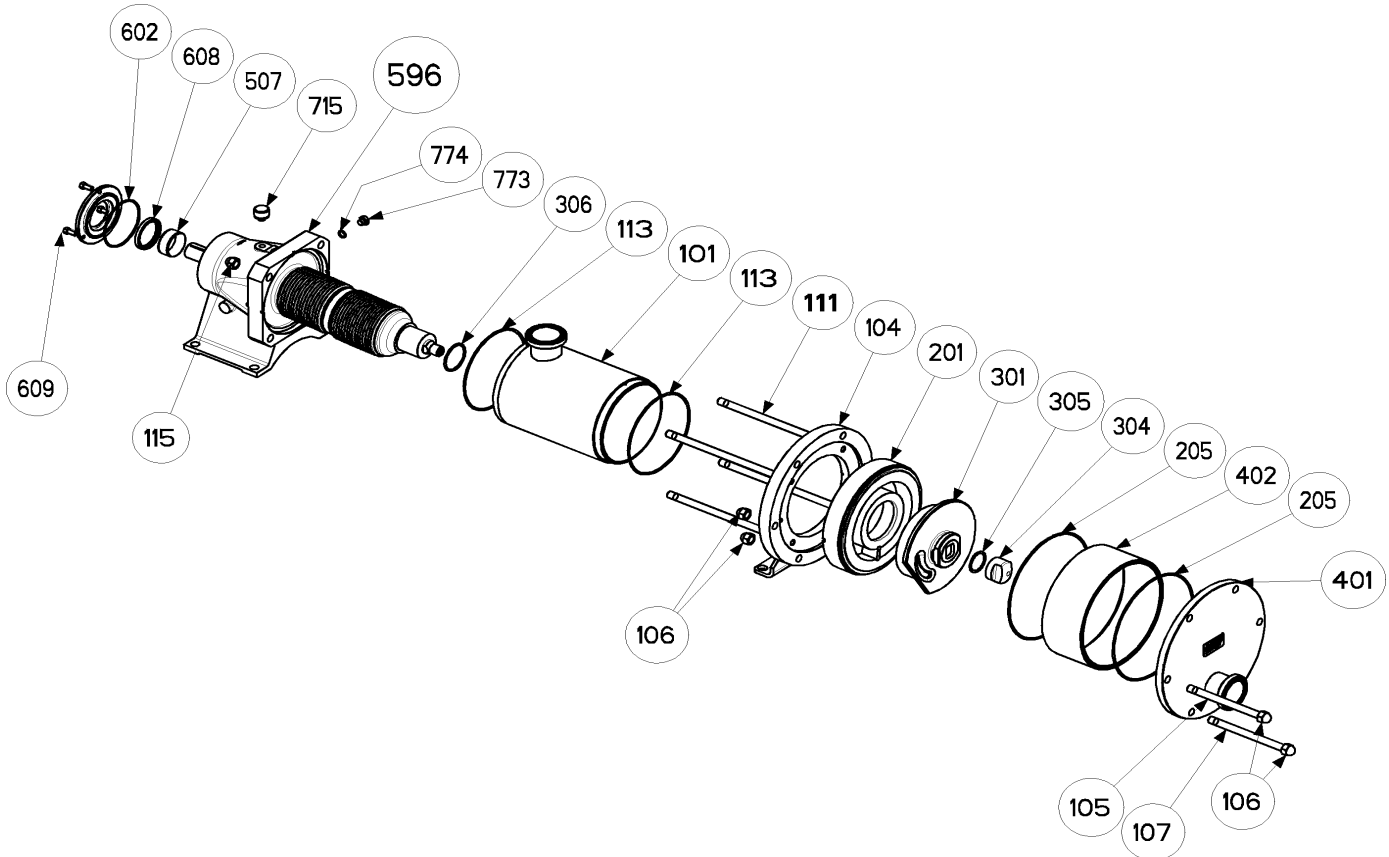

Reference			Description	Quantity		ARTICLE CODE		Wear parts
Ass.	Part	Available		Order	In Pump	C12 i	C18 i	
100		◆	Inlet Manifold PN16 DN65	1		311582.00		
100		◆	Inlet Manifold PN20 DN65	1		311726.00		
100		◆	Inlet Manifold SMS 63	1		311581.00		
100		◆	Inlet Manifold DIN 65	1		311646.00		
100		◆	Inlet Manifold CHERRY BUREL 63	1		311607.00		
100		◆	Inlet Manifold CLAMP ISO 63	1		311644.00		
100		◆	Inlet Manifold IDF 63	1		311648.00		
100		◆	Inlet Manifold Smooth Pipes	1		311650.00		
100		◆	Inlet Manifold ASEPTIK DIN 11864-BF-A DN65	1		313559.00		
100		◆	Inlet Manifold CS F DN65 VR	1		313894.00		
100		◆	Inlet Manifold BS4825-5 DN65	1		313990.00		
100		◆	Jacketed Inlet Manifold PN16 DN65	1		311854.00		
100		◆	Jacketed Inlet Manifold PN20 DN65	1		311860.00		
100		◆	Jacketed Inlet Manifold SMS 63	1		311853.00		
100		◆	Jacketed Inlet Manifold DIN 65	1		311858.00		
100		◆	Jacketed Inlet Manifold CHERRY BUREL 63	1		311855.00		
100		◆	Jacketed Inlet Manifold CLAMP ISO 63	1		311857.00		
100		◆	Jacketed Inlet Manifold IDF 63	1		311859.00		
100		◆	Jacketed Inlet Manifold Smooth Pipes	1		311856.00		
100		◆	Jacketed Inlet Manifold ASEPTIK DIN 11864-BF-A DN65	1		313572.00		
100		◆	Jacketed Inlet Manifold CS F DN65	1		313897.00		
100		◆	Jacketed Inlet Manifold BS4825-5 DN65	1		313992.00		
	101		Main body		(1)			
	104		Main body flange		(1)			
	108		Support foot		(1)			
	109		Screw		(2)			
	117		Pin		(2)			
	118		Pin		(1)			
	124		Plug (with Jacketed Inlet)		(2)			

(◆) Sets of parts or (▲) parts available to order

Reference			Description	Quantity		ARTICLE CODE		Wear parts
Ass.	Part	Available		Order	In Pump	C12 i	C18 i	
119		◆	Set of studs and nuts	1		311580.00	311748.00	
	105		Stud		(4)			
	106		Blind nut		(12)			
	107		Stud		(2)			
	111		Stud		(4)			
	115		Blind nut		(4)			
	123		Washer		(4)			
200		◆	Set cylinder/Piston	1		312865.04	312867.00	•
	201		Cylinder		(1)			
	301		Piston		(1)			
	304	▲	Piston nut	1		218053	218397	
206		◆	Set of FKM 'O' ring seals	1		311588.00		•
206		◆	Set of CVT 'O' ring seals	1		311589.00		•
206		◆	Set of FKM lip seals ('L' rings) FDA	1		311763.00		•
206		◆	Set of L. PTFE seals ('L' rings)	1		311812.04		•
	113		Seal		(2)			
	205		Seal Ring		(2)			
	305		Seal		(1)			
	306		Seal		(1)			
400		◆	Front Cover Plate PN16 DN65	1		311591.00		
400		◆	Front Cover Plate PN20 DN65	1		311728.00		
400		◆	Front Cover Plate SMS 63	1		311590.00		
400		◆	Front Cover Plate DIN 65	1		311639.00		
400		◆	Front Cover Plate CHERRY BURREL 63	1		311609.00		
400		◆	Front Cover Plate CLAMP ISO 63	1		311637.00		
400		◆	Front Cover Plate IDF 63	1		311641.00		
400		◆	Front Cover Plate Smooth pipes	1		311643.00		
400		◆	Front Cover Plate ASEPTIK DIN 11864-BF-A DN65	1		313557.00		
400		◆	Front Cover Plate CS F DN65	1		313903.00		
400		◆	Front Cover Plate BS4825-5 DN65	1		313993.00		
	401		Front cover		(1)			
	402		Outlet tube		(1)			
596		◆	Complete transmission	1		313789.00		
596		◆	Complete transmission + Pressure switch bellows monitoring system	1		313670.01		
596		◆	Complete transmission + ATEX pressure switch bellows monitoring system	1		313786.00		
596		◆	Complete transmission + Pressure gauge bellows monitoring system	1		314793.00		
596		◆	Complete transmission - Jacketed version	1		313848.00		
596		◆	Complete transmission - Jacketed version + Pressure switch bellows monitoring system	1		313671.01		
596		◆	Complete transmission - Jacketed version + ATEX Pressure switch bellows monitoring system	1		313791.00		
596		◆	Complete transmission - Jacketed version + Pressure gauge bellows monitoring system	1		314792.00		
	9	◆	Bearing gaskets / screws	1		312855.01		
	507		Ring		(1)			
	602		Gasket		(1)			
	608		Lip seal		(2)			
	609		Bearing screws		(3)			
	8	◆	Plugs + gasket	1		314259.00		
	715		Breather		(1)			
	773		Drain plug		(1)			
	774		Copper-plated gasket		(1)			

CVT - FEP encapsulated FKM ; FDA : Food and Drug Administration (21 CFR 177 2600)

(◆) Sets of parts or (▲) parts available to order

Keep this parts lists with Installation, Operation and Maintenance Instructions

To order the required spare parts, indicate the appropriate CUM numbers.



Z.I. la Plaine des Isles - 2 rue des Caillottes F-89000 AUXERRE - France

Tel : +33 (0)3 86 49 86 30 • Fax : +33 (0)3 86 49 87 17