

BLK pumps

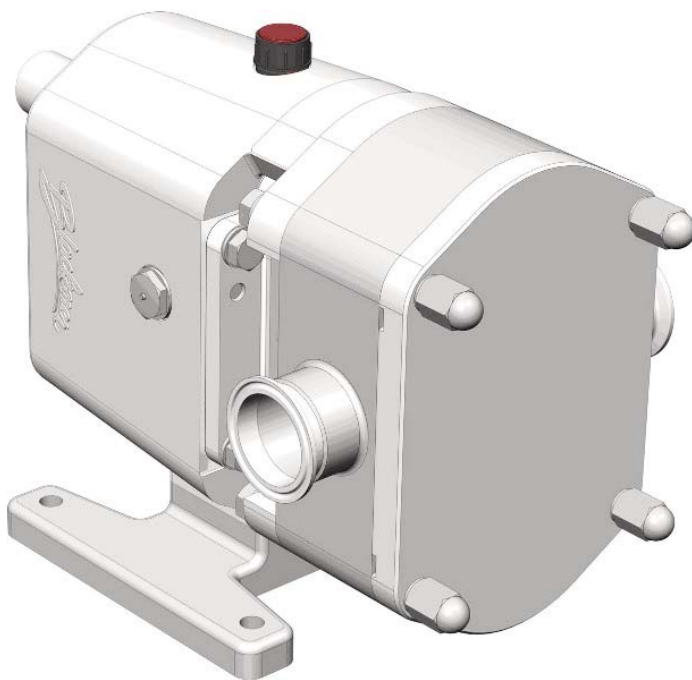

INSTALLATION

OPERATION

MAINTENANCE

1. Safety

1.1. INSTRUCTION MANUAL

This instruction manual contains information on the reception, installation, operation, fitting, stripping and maintenance for the BLK pump.

The information given herein is based on the most up-to-date data available.

MOUVEX reserves the right to modify this instructions manual without having to give prior notice.

1.2. START-UP INSTRUCTIONS

This instruction manual contains vital and useful information for properly operating the pump and for keeping it in good running condition.

Not only should the safety instructions set forth in this chapter be carefully read before putting the pump into operation, but those concerned must also familiarize themselves with the operating features of the pump and strictly adhere to the instructions given herein. It is extremely important that these instructions be kept in a set place near the installation.

1.3. SAFETY

1.3.1. Warning signs



Danger for people in general.



Danger of injury caused by rotating parts of the equipment.



Danger! Electricity.



Danger! Caustic or corrosive agents.



Danger! Suspended loads.



Danger to the proper operating of the machine.



Obligation to ensure safety at work.



Use of safety goggles obligatory.

1.4. GENERAL SAFETY INSTRUCTIONS



Please read the instruction manual carefully before installing and commissioning the pump. Should you have any doubts or queries, contact MOUVEX.

1.4.1. During the installation



You must always bear in mind the *Technical Specifications* set forth in Chapter 8.

Do not put the pump into operation before connecting it to the pipes.

Do not put the pump into operation if the cover of the pump has not been fitted and the impeller fixed in the pump.

Check that the motor specifications are correct, especially if there is a special risk of explosion due to the work conditions.



During the installation procedure, all the electrical work must be carried out by duly authorized personnel.

1.4.2. During operation



You must always bear in mind the *Technical Specifications* set forth in Chapter 8. The limit values that have been set must NEVER be exceeded.

NEVER touch the pump or pipes whenever the pump is being used to decant hot liquids or during the cleaning procedure.



The pump has moving parts. Do not put your fingers into the pump when it is operating.



NEVER work with the suction and the delivery valves shut off.

NEVER directly sprinkle the electric motor with water. Standard motor protection is IP-55: dust and water sprinkling protection.

1.4.3. During maintenance



You must always bear in mind the *Technical Specifications* set forth in Chapter 8.

NEVER strip the pump down until the pipes have been drained. Remember that there will always be some liquid left in the rotor case (if it has not been fitted with a drain). Always remember that the liquid that has been pumped may be dangerous or subject to high temperatures. For situations of this type, please consult the prevailing regulations in the country in question.

Do not leave loose parts on the floor.



ALWAYS turn the power supply to the pump off before embarking on maintenance work. Take out the fuses and disconnect the wires from the motor terminals.

All electrical work must be carried out by duly authorized personnel.

1.4.4. In accordance with the instructions

Any failure to comply with the instructions could lead to hazards and to a loss to any right to claim for damages. Such non-compliance could bring with it the following risks:

- People injuries.
- Important operating failures of the machine / plant.
- Failure to comply with specific maintenance and repair procedures.
- Potential electrical, mechanical and chemical hazards.
- Atmospheric conditions in the room could be hazardous due to the release of chemical substances.

1.4.5. Warranty

We wish to point out that any warranty issued will be null and void and that we are entitled to an indemnity for any civil liability claim for products which might be filed by third parties if:

- Operation and maintenance work has not been done following the corresponding instructions; the repairs have not been made by our personnel or have been made without our written authorization;
- Modifications are made to our material without prior written authorization;
- The parts or lubricants used are not original MOUVEX parts/lubricants;
- The material has been improperly used due to error or negligence or has not been used according to the indications and the intended purpose.
- The parts of the pump have been damaged as a result of having been exposed to strong pressure as there was no relief valve.

The General Delivery Terms which you have already received are also applicable.



No modification can be made to the machine without the prior consent of the manufacturer. For your safety, use spare parts and original accessories. The use of other parts exempts the manufacturer from any and all responsibility.

Any change in operating conditions can only be done with the prior written consent of MOUVEX.

In the event of doubt or should you require a fuller explanation on particular data (adjustment, assembly, disassembly...), please do not hesitate to contact us

2. Index

1. Safety	
1.1. Instruction manual	2
1.2. Start-up instructions	2
1.3. Safety	2
1.4. General safety instructions	2
2. Index	
3. General Information	
3.1. Description	6
3.2. Operating Principle	6
3.3. Application	6
4. Installation	
4.1. Pump reception	8
4.2. Transport and storage	8
4.3. Location	9
4.4. Coupling	9
4.5. Pipes	10
4.6. Secondary piping	11
4.7. Relief valve	12
4.8. Electrical installation	12
5. Start-up	
5.1. Start-up	13
5.2. Pressure Relief valve	13
6. Operating Problems	
7. Maintenance	
7.1. General maintenance	16
7.2. Storage	16
7.3. Cleaning	17
7.4. Pump disassembly	18
7.5. Pump assembly	20
7.6. Lobe adjustment	23
7.7. Mechanical seal assembly and disassembly	25
8. Technical Specifications	
8.1. Technical specifications	27
8.2. Weights	29
8.3. BLK pump dimensions	30
8.4. BLK dimensions (vertical inlets)	31
8.5. Dimensions pump with flushing and/or sealing heating jacket and front heating jacket	32
8.6. Dimensions zb	33
8.7. Dimensions rectangular inlet	34

8.8. Dimensions flange connections to DIN 2633 PN 16 and DIN 2634 PN 25	34
8.9. BLK 1	35
8.10. BLK 2	37
8.11. BLK 3	39
8.12. BLK 4	41
8.13. BLK 5	43
8.14. Relief valve valve	45
8.15. Front heating jacket	46
8.16. Heating jacket around shaft sealing.....	47

3. General Information

3.1. DESCRIPTION

The BLK lobe pumps by MOUVEX are part of our wide range of positive displacement rotary pumps for viscous liquids. The following models exist in the lobe pump range:

- The BLK pump normal flow rate suitable for differential pressure of up to 12 bar.
- The BLK with wider lobes, delivers a higher flow rate, and is suitable for differential pressure of up to 7 bar.

The BLK model has been specially developed to respond to all hygienic requirements in the food industry. As regards hygiene, reliability and sturdiness, the complete range of lobe pumps satisfies all requirements set by the aforesaid industry. Its modular design enables optimal part interchange between the different pumps.

The lobe pumps are rotary displacement pumps. Owing to the contact between the internal parts, the pressure variations, etc. they make a louder noise than centrifugal pumps. This noise must be taken into consideration when installing these pumps. The BLK rotary lobe pumps by MOUVEX have been designed so that they meet the requirements of 3-A Sanitary Standard #02-10.

This equipment is suitable for use in food process. MOUVEX also proposes a range of lobe pumps certified EHEDG : the BLK Hyclean.

3.2. OPERATING PRINCIPLE

The lobe pump is a positive displacement rotary pump. The top lobe (except in the case of pump size 1) is located on the driven shaft, and is driven via a helical gear. The lower lobe is driven by the driving shaft (depending of sizes. In option, possibility to invert the driving/driven shafts). Both lobes rotate in synchronism without one touching the other. When the pump is running they displace a set volume of liquid. Figure below shows how a lobe pump operates.

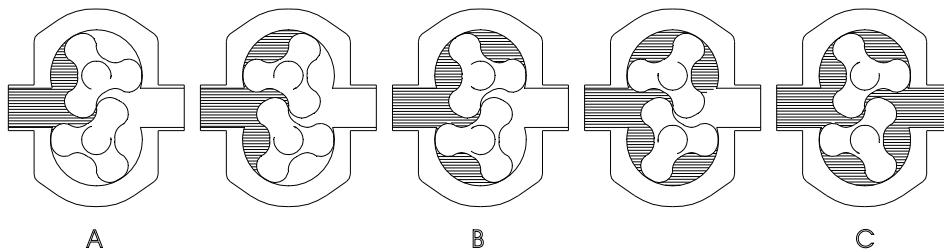

A: When the lobes rotate, the space on the suction side increases because one lobe moves away from the other, thus causing a partial vacuum that draws the liquid into the pumping chamber.

B: Each lobe void is filled consecutively as the shafts rotate and the liquid is displaced towards the discharge side. The small clearances between the lobes, and between the lobes and the walls of the rotor case duly cause the spaces to be rather well closed.

C: The rotor case is completely full and the liquid leaks through the discharge port.

3.3. APPLICATION

The main advantage of the MOUVEX BLK lobe pump is its capacity to pump a great variety of viscous liquids, from 1 mPa.s up to 100.000 mPa.s

Furthermore, it is capable of pumping liquid products that require very careful handling and liquids that contain soft solids thus causing only a minimum degradation of same.

3.3.1. Field of application

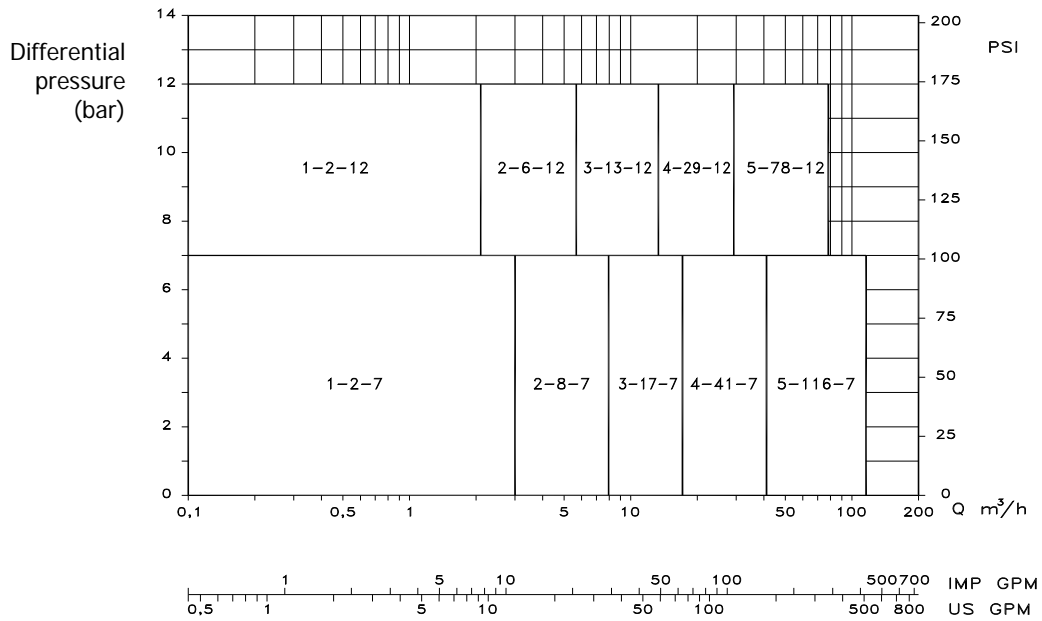

The range of application for each type of pump is limited. The pump was selected for a given set of pumping conditions when the order was placed. MOUVEX shall not be liable for any damage resulting from the incompleteness of the information provided by the purchaser (nature of the fluid, rpm, etc.).

4. Installation

4.1. PUMP RECEPTION



MOUVEX is not responsible for any deterioration of the material as a result of its transportation or unpacking. Visually check that the packing has not suffered any damage.

The pump will be accompanied by the following documentation:

- Dispatch notes.
- Pump Instruction and Service Manual.
- Drive Instruction and Service Manual (*).

(*) If the pump has been supplied with a drive from MOUVEX.

Unpack the pump and check the following:

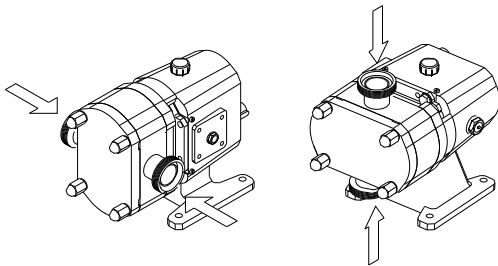

- The pump suction and delivery connections, removing the remains of any packing material.
- Check that the pump and the motor have not suffered any damage.
- Should the pump not be in proper condition and/or does not have all the parts, the haulier must draw up a report as soon as possible with regard to the same.

4.1.1. Pump identification and marking

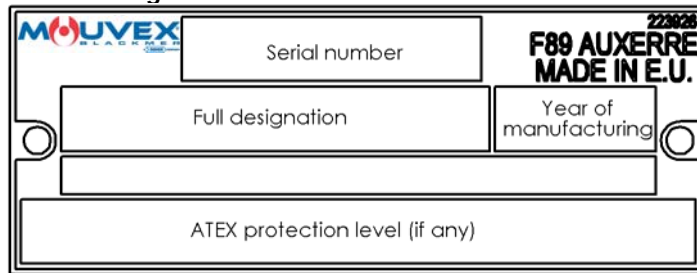

Pump plate

4.2. TRANSPORT AND STORAGE



BLK pumps and pumping units are often too heavy to be handled manually. Use an adequate means of transport.

Use the points which are indicated in the drawing for lifting the pump.

Only authorized personnel should transport the pump.

Do not work or walk under heavy loads.

Lift the pump as shown below:

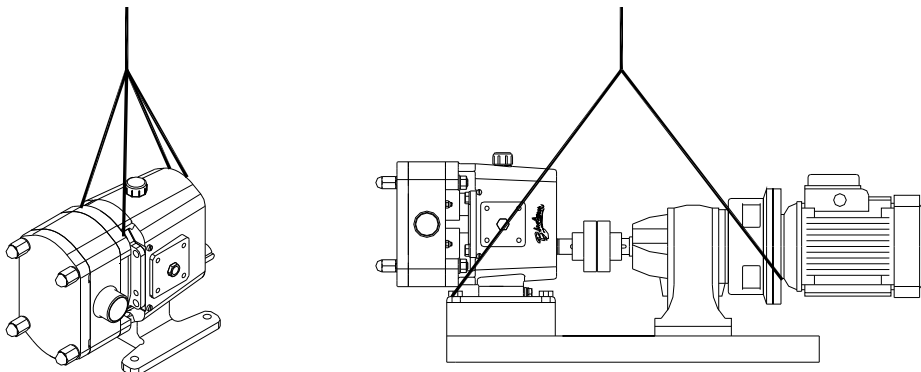

- Always use two support points placed as far apart as possible.
- Secure the supports so that they will not move.
- See chapter **8. Technical Specifications** to consult dimensions and weights.

4.3. LOCATION

- Position the pump as near as possible to the suction tank, and whenever possible below the level of the liquid.
- Place the pump in such a way that there is enough space around it to provide access both to the same and to the motor.
(See Chapter 8. *Technical Specifications* to consult dimensions and weights).
- Place the pump on a level and flat surface.
- The basement must be rigid, horizontal and against any vibration.



Install the pump in such a way that it can be properly ventilated. If the pump is to be installed outside, it must be done so under cover. Its positioning must enable easy access for any inspection and maintenance operations that may need to be carried out.

4.3.1. Foundation

Install the pump base so that the drive and pump are level and well supported. Therefore the pump unit should be installed on a base plate –according to DIN 24259–, or on a frame, both placed exactly level on the foundation. The foundation must be hard, level, flat, and vibration free ...to prevent base distortion (to keep the alignment pump –drive guaranteed while commissioning).

To install the pump unit on the foundation proceed as follows:

- Make holes in the foundation to fit foundation bolts. This is unnecessary when expanding screws are used instead of foundation bolts.
- Place base plate or frame with the aid of shims horizontally on the foundation.
- Grout
- When the grout has entirely hardened the pump unit can be placed on the baseplate or the frame. Tighten the nuts on the foundation bolts carefully.

For other foundations consult MOUVEX.

4.4. COUPLING

For the couplings selection and assembly consult to the supplier manual. Sometimes the torque of the positive displacement pumps can be high enough. Therefore, a coupling have been chosen 1.5 to 2 the adequate torque.

4.4.1. Alignment

The pump and motor shaft of complete units have been accurately pre-aligned in our factory.



After installations of the pump unit, the pump and motor shaft should be re-aligned.

- After unit is installed recheck alignment of pump and motor shaft and alignment of piping. Realign if necessary.
- In the case of applications dealing with high temperatures the pump can be operated temporarily at its working temperature. Then recheck alignment pump - piping.

Place a straight-edge (A) on top of the coupling: the straight should make contact with both halves of the coupling over their entire length. See figure.

Repeat the check, but this time on both sides of the coupling near the shaft. For the sake of accuracy, this check should also be done using an outside caliper (B) at two diametrically opposite points on the outside surfaces of the two halves of the coupling.

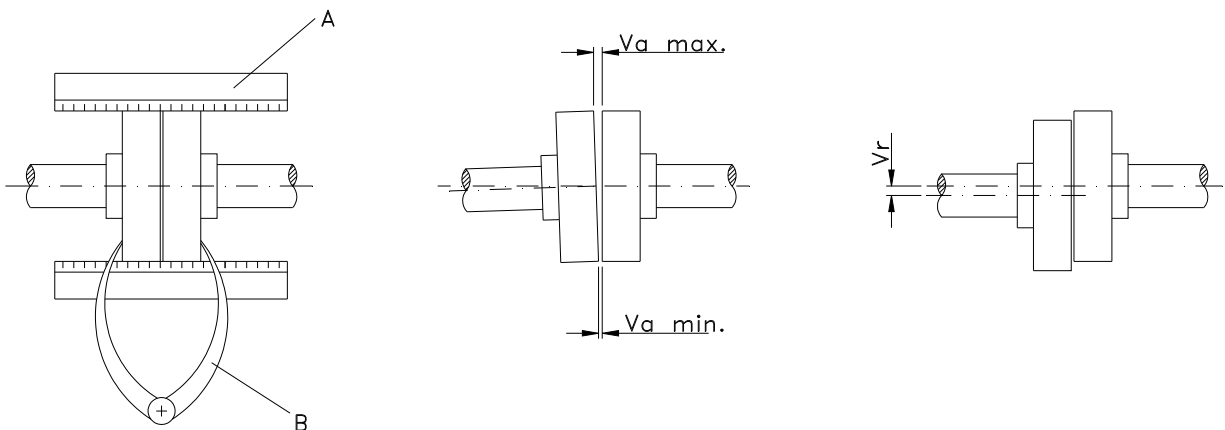

Maximum alignment deviations:

Outside diameter of the coupling [mm]	Va min. [mm]	Va max. [mm]	Va max. - Va min. [mm]	Vr max. [mm]
70 - 80	2	4	0,13	0,13
81 - 95	2	4	0,15	0,15
96 - 110	2	4	0,18	0,18
111 - 130	2	4	0,21	0,21
131 - 140	2	4	0,24	0,24
141 - 160	2	6	0,27	0,27
161 - 180	2	6	0,3	0,3
181 - 200	2	6	0,34	0,34
201 - 225	2	6	0,38	0,38

4.5. PIPES

- In general, suction and delivery pipes should be fitted in straight stretches, with the minimum amount of elbows and accessories, in order to reduce, as far as possible, any head loss that might be produced by friction.
- Make sure that the pump ports are well aligned with respect to the piping and that they are similar in diameter to that of the pipe connections.
- Position the pump as near as possible to the suction tank, and whenever possible below the level of the liquid, or even lower with respect to the tank in order for the static suction head to be at its maximum.
- Place brackets for the piping as near as possible to the suction and delivery ports of the pump.

4.5.1. Shut-off valves

The pump can be isolated for the purpose of carrying out maintenance work. To this end, shut-off valves should be fitted at the pump's suction and delivery connections.



These valves must ALWAYS be open whenever the pump is operating.

4.5.2. Self-priming process

In general terms --if the self-priming process is followed-- the pump ought to contain sufficient liquid to fill the internal recesses and the void spaces thus enabling the pump to create a pressure difference.

However, if low viscosity fluids are to be pumped, a foot valve of the same or greater diameter as that of the suction pipe should be installed; alternatively, the pump can be installed with a "U" shaped piping.



The use of a foot valve is not recommended for pumping viscous liquids.

In order to eliminate air and gases from the suction pipe, the counter-pressure on the discharge pipe should be reduced. When the self-priming process is used, the pump's start-up should be done by opening and emptying the discharge pipe which allows the air and gases to escape at a low counter-pressure.

Another possibility involves long pipes or when a check valve is installed in the discharge pipe; it is also possible to install a relief valve with a shut-off valve on the discharge side of the pump. This valve shall be opened in the case of priming and will allow air and gases to escape at a minimum counter-pressure.

The relief valve should not lead back to the intake orifice but to the supply tank instead.

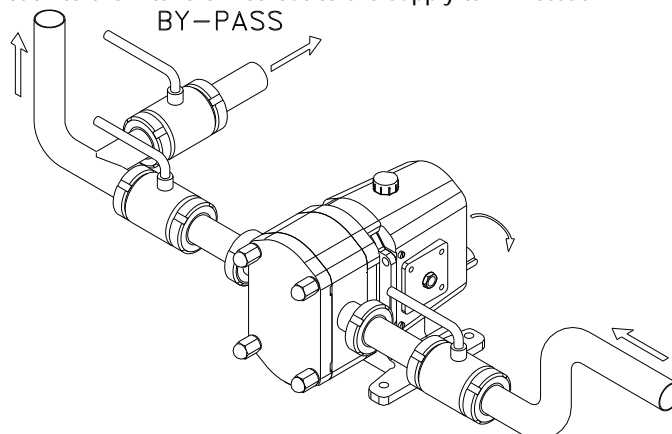

4.5.3. Pressure tank

For models with double mechanical seal the installation of a pressure tank could be necessary.



Install **ALWAYS** the pressure tank between 1 and 2 meters above the mechanical seals. See the figure below.

Connect **ALWAYS** the refrigeration liquid input connection with the bottom chamber seal connection. So, the refrigeration liquid outlet will be carried out by the top chamber connection. See the figure below

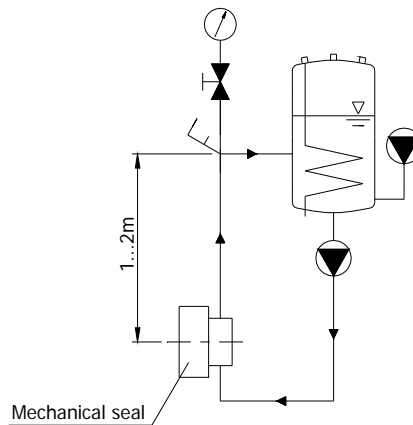

Pressure tank connection lay out

To obtain further information about the pressure tank (installation, operation, maintenance, ...); consult the instruction manual supplied by the manufacturer.

4.6. SECONDARY PIPING

4.6.1. Flushing

If the seal requires flush media, the media supply and the purchase and installation of piping, valves ... for the media are not the responsibility of MOUVEX.

The flush shaft seal option (F) is available on all seal types. Use the sectional drawings of the BLK seal options to purchase additional parts.



Attention should be given to the compatibility of the handled liquid with the flush media. Choose the sealing liquid so that unwanted chemical reactions are avoided. Also check the compatibility of the flush media with seal elastomers.

BLK rotor cases have female threaded inlet and outlet connections and are dependent upon frame of the pump and type of flush system employed.

4.6.2. Liquid flush media

Use a flush media which is filtered free from impurities to obtain maximum service life of the seal. If the product is sticky or crystalline then use media which is able to dissolve the product.

Connect the flush so that the inlet is at the bottom and outlet is at the top. This will make a better evacuation of air or gases possible.

4.6.3. Heating / cooling jackets

Heating / cooling jackets (S) are available on the front cover or/and around the seal. Heating or cooling media can be provided via connections according to next figure.

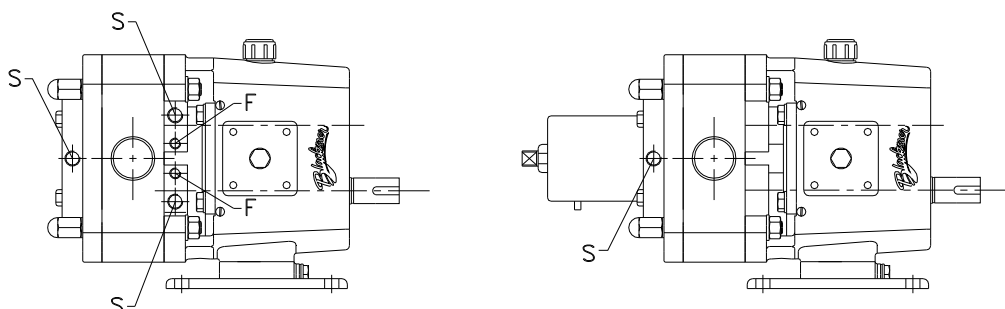

4.7. RELIEF VALVE



The positive displacement lobe pumps must be protected from excess pressure when they are operating. Consequently, all the BLK pumps can be fitted with a stainless steel relief valve or a pressure relief valve

4.7.1. Protection

This valve protects the pump and prevents excessively high pressure arising in the circuit. It reduces the differential pressure (Δp) between suction and discharge, but not the maximum pressure within the plant.



Do not use the relief valve to protect the system from excess pressure. It is designed to protect the pump only as it is not a safety outlet.

4.7.2. Operation principle

The pressure relief valve is located in the rotor case and prevents excess pressure arising inside the pump. For example, when the pump's discharge port is clogged and the liquid cannot be pumped out, too high a pressure can cause serious damage to some of the pump's parts. The relief valve opens a passage from the pump's discharge side to its suction side: an escape route, redirecting the flow again to the suction side whenever specifically high pressure levels are reached. The relief valve is effective in both directions of rotation.



If the relief valve operates, this will mean that the equipment is not working properly. The pump should be disconnected immediately. Identify and solve the problem before re-starting the pump.



Remember that the relief valve in the pump is not able to be used to regulate the flow rate. If the relief valve is not fitted in the pump, other steps should be taken to protect the pump from excess pressure.

The relief valve can be adjusted to any determined pressure, according to the type of pump being used.

4.8. ELECTRICAL INSTALLATION



Leave the connecting of the electrical motors to qualified personnel. Take the necessary measures to prevent any breakdowns in the connections and wires.



The electrical equipment, the terminals and the components of the control systems may still carry an electric charge even when disconnected. Contact with them may put the safety of operators at risk, or cause irreparable damage to the material.

Before maneuvering the pump, make sure that the electric box is switched off.

- Connect the motor in accordance with the instructions supplied by the manufacturer of the same.
- Check the direction of the rotation (see the signaling label on the pump).

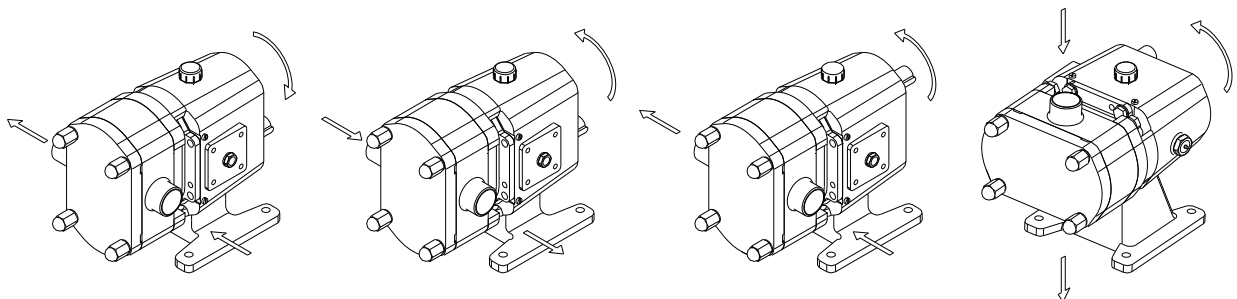

- Start the pump motor briefly. Make sure the pumping direction is the right one. If the pump operates in the wrong direction it may cause severe damage.



Check ALWAYS the direction of the motor's rotation with liquid inside the pump.

For the models with double mechanical seal always check they are filled with liquid barrier before checking the liquid direction.

5. Start-up



Before putting the pump into operation read carefully the instructions on installation given in Chapter 4. *Installation*.

5.1. START-UP



Read Chapter 8. *Technical Specifications* carefully. MOUVEX will not assume responsibility for any improper or incorrect use of the equipment.



Do not touch the pump or the piping while it is pumping products at a high temperature.

5.1.1. Checks to be carried out before putting the pump into operation

- Completely open the pipes' suction and delivery shut-off valves.
- Take care to mount the breather on the transmission, instead of the sealing plug used during the transport.
- Check oil level of the pump. Add correct grade of oil as necessary to maintain level in center of oil sight glass (in case of first start-up: even if pumps are shipped with the right oil quantity, always check the oil level before start).
- If the liquid fails to flow toward the pump, fill it with the liquid to be pumped.



The pump must NEVER rotate without fluid inside it.

- Check that the power supply matches the rating indicated on the motor plate.
- Check that the direction of rotation of motor is the right one.
- If the pump has a double or a flushed mechanical seal, mount the auxiliary connection corresponding to the values indicated in *Chapter 8, Technical Specifications*.

5.1.2. Checks to be carried out on putting the pump into operation

- Check to make sure that the pump is not making any strange noises.
- Check to see if the absolute inlet pressure is sufficient, in order to avoid cavitations in the pump. Consult the curve for the minimum required pressure above the steam pressure (NPSHr).
- Monitor the delivery pressure.
- Check that there are no leaks in the sealed areas.



A shut-off valve should not be used in the suction pipe to regulate the flow rate. It must be completely open during operation.



Monitor motor consumption in order to avoid a circuit overload.

Reduce flow and motor power consumption by reducing motor speed.

5.2. PRESSURE RELIEF VALVE

The valve's opening pressure depends on the fluid to be pumped, its viscosity, its rpm ..., and so before starting-up the pump, the operator ought to adjust the relief valve's opening pressure.

5.2.1. Front Cover Assembly

When the relief valve is equipped this valve has been adjusted to the pump's maximum operating pressure. The operator must check this by observing the position of the pin (55D). When the pin is completely displaced to the pump cover, valve has been set at the pump's maximum pressure.

To obtain the correct opening pressure, the following procedure should be followed:

- Loosen the nut (54C).

- Using a spanner, turn the adjusting screw (25A) to the right to reduce the spring tension, and thus obtain the required opening pressure. When making this operation, observe that the pin's position (55D) backs up to position of the pump cover.
- If the correct opening pressure has been obtained, tighten the nut (54C).



When checking the relief valve also make sure the pump's pressure will NEVER exceed the pressure setting + 2 bar.



When the relief valve does not work properly, the pump must be taken out of service immediately. The valve must be inspected by a MOUVEX service technician.

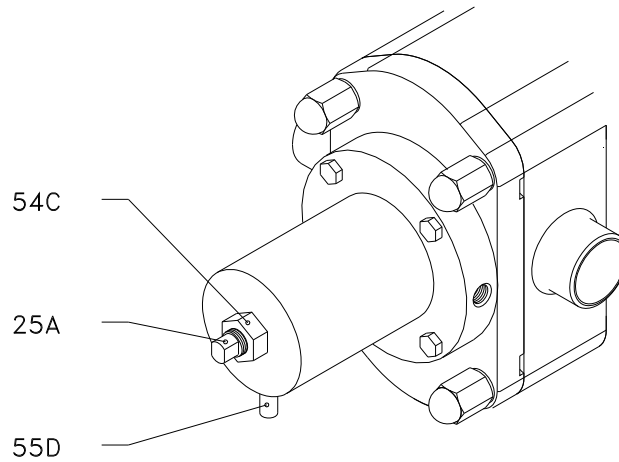

Springs types that can fit in function of the pressure setting:

Types	2-7 bar	7-12 bar
BLK 1-2-12	-	-
BLK 1-2-7	-	
BLK 2-6-12	X	X
BLK 2-8-7	X	
BLK 3-13-12	X	X
BLK 3-17-7	X	
BLK 4-29-12	X	X
BLK 4-41-7	X	
BLK 5-78-12	X	X
BLK 5-116-7	X	

6. Operating Problems

The table given below provides solutions to problems that might arise during pump operation. With respect to the same, it is assumed that the pump has been properly installed and has been correctly selected for the application in question. Should there be a need for technical service please contact MOUVEX.

Operating problems	Probable causes
Motor overload	8, 9, 12, 16, 20, 21, 22, 23, 24, 26.
Insufficient discharge flow rate	2, 4, 5, 7, 8, 9, 10, 11, 13, 14.
No pressure on the discharge side	1, 2, 3, 6, 7.
Irregular discharge flow rate/pressure	2, 4, 5, 6, 9, 12.
Noise and vibrations	2, 4, 5, 6, 7, 8, 9, 11, 12, 13, 16, 19, 20, 21, 22, 23, 24, 25, 26.
The pump gets clogged	8, 9, 11, 16, 19, 20, 21, 22, 24, 25, 26.
Overheating of pump	7, 8, 9, 11, 12, 16, 20, 21, 22, 23, 24, 26.
Abnormal wear	4, 5, 11, 15, 16, 19, 24, 25.
Leak through mechanical seal	17, 18, 27.

Probable causes	Solutions
1 Wrong rotation direction	Invert the rotation direction
2 Insufficient NPSH	Increase available NPSH: - Rise the suction tank - Lower the pump - Reduce the speed - Increase the diameter of the suction pipe - Shorten and simplify the suction piping.
3 Pump not purged	Purge or fill
4 Cavitation	Increase suction pressure (see 2)
5 The pump sucks in air	Check suction pipe and all its connections.
6 Suction pipe clogged	Check the suction pipe and filter(s), if any.
7 Wrong setting of relief valve	Check the relief valve's setting
8 Discharge pressure too high	If necessary, reduce the loss of head by increasing the diameter of the discharge pipe
9 Viscosity of the liquid is too high	- Reduce the pump speed - Reduce the viscosity, for example, by heating the liquid..
10 Viscosity of liquid too low.	- Increase the pump speed - Increase the viscosity, for example, by cooling the liquid.
11 Temperature of liquid too high.	Reduce the temperature by cooling the liquid.
12 Pump speed too high	Reduce the pump speed
13 The lobes are worn	Replace the lobes
14 Pump speed too low	Increase the pump speed
15 Product very abrasive	Fit hardened lobe hubs
16 Worn bearings	Replace the bearings, check the pump
17 Worn or damaged mechanical seal	Replace the seal
18 O-rings not the right ones for the liquid	Fit the proper O-rings; check with the supplier.
19 Worn gears	Replace and readjust the gears
20 Insufficient lubricating oil level	Fill up with oil
21 Unsuitable lubricating oil	Use an appropriate oil
22 The lobes rub	- Reduce the temperature - Reduce the discharge pressure - Adjust the clearance
23 Coupling misalignment	Align the coupling
24 Tension on the pipelines	Connect the pipelines to the pump free of tensions
25 Foreign bodies in the liquid	Insert a filter in the suction pipe
26 Pump and / or electric motor not fixed on foundation	Tighten, check that the piping has been connected stress-free and align the coupling
27 Mechanical seal spring tension too low	Adjust as indicated in this manual



If the problem persists, use of the pump must cease immediately. Contact the pump's manufacturer or its representative.

7. Maintenance

7.1. GENERAL MAINTENANCE

This pump, as with any other machine, needs to be maintained. The instructions contained in this manual deal with the identification and replacement of the spare parts. These instructions have been drawn up by maintenance staff and are destined for those people who are responsible for supplying spare parts.



Read carefully Chapter 8. *Technical specifications*.

All the parts or materials that are changed must be duly eliminated /recycled in accordance with the prevailing directives in each area.



ALWAYS disconnect the pump before starting out on any maintenance work.

7.1.1. Check the mechanical seal

Periodically check that there are no leaks in the shaft area. Should there be any leaks in the mechanical seal area, replace the same pursuant to the instructions given in the *Pump Disassembly and Assembly* section.

7.1.2. Dry thread torque

Material	Dry thread torque [N.m]								
	M5	M6	M8	M10	M12	M14	M16	M18	M20
8.8	6	10	25	49	86	135	210	290	410
A2	5	9	21	42	74	112	160	210	300

7.1.3. Oiling

The bearings are oiled by immersion in an oil bath.

The pumps are supplied with oil.

- Regularly check the oil level, for example, weekly or every 150 operating hours.
- The first oil change must be carried out after 150 hours of operation.
- Afterwards, it can be changed every 2500 operating hours or at least once a year when operating under normal conditions.

When change the oil: the oil sump must be filled up to the level in the middle of the peephole.



Do not pour too much oil into the sump.

Leave the pump switched off for a while and then re-check the oil level; if necessary, add a little oil.

Oils for environment temperatures of 5 to 50°C: SAE 90 or ISO VG 220

PUMP TYPE	Quantity of oil in the Gear Case (L)
BLK 1	0,3
BLK 2	0,5
BLK 3	0,75
BLK 4	1,75
BLK 5	4,5

7.2. STORAGE

Before being stored the pump must be completely emptied of liquids. Avoid, as far as possible, the exposure of the parts to excessively damp atmospheres.

7.3. CLEANING

7.3.1. Manual cleaning



The use of aggressive cleaning products such as caustic soda and nitric acid may give rise to skin burns.

Use rubber gloves during the cleaning process.



Always use protective goggles.

7.3.2. Automatic CIP (cleaning-in-place)

If the pump is installed in a system fitted with a CIP process, there will be no need for stripping.

The recommended minimum liquid speed for an effective process of cleaning is $1,8 \text{ m}\cdot\text{s}^{-1}$ (minimum $\text{Re} > 100\,000$ at 1,0–2,5 bar).

It is recommended to run the pump during the CIP process (rotation speed: same as nominal speed when used as pump).

If it is not fitted with an automatic cleaning process, strip the pump pursuant to the instructions given in the section entitled Stripping and Assembly of the pump.

Cleaning solutions for CIP processes.

Only use clear water (chloride free) to mix with the cleaning agents:

- a) Alkaline solution :** 1% in weight of caustic soda (NaOH) to 70°C (150°F)
- 1 kg NaOH + 100 L water = cleaning solution
or
2,2 L NaOH to 33% + 100 L of water = cleaning solution
- b) Acid solution :** 0,5% in weight of nitric acid (HNO₃) to 70°C (150°F)
- 0,7 L HNO₃ to 53% + 100 L water = cleaning solution



Monitor the concentration of cleaning solutions; it could give rise to the deterioration of the pump sealing gaskets.

These solutions are given as examples and should be validated before use on an application.

In order to remove any remains of cleaning products, ALWAYS rinse the element in question with clean water after completing the cleaning process.

7.3.3. Automatic SIP (sterilization-in-place)

The process of sterilization with steam is applied to all the equipment including the pump.



Do NOT start the pump during the process of sterilization with steam.

The parts/materials suffer no damage if the indications specified in this manual are observed.

No cold liquid can enter the pump till the temperature of the pump is lower than 60°C (140°F).

As the pump creates a high head loss during the sterilization process, we recommend the use of a second piping with a relief valve in order to ensure that the steam / overheated water could sterilize the whole installation.

Maximum conditions during the SIP process with steam or overheated water

- a) Max. temperature :** 140°C (284°F)
- b) Max. time :** 30 min
- c) Cooling :** Sterile air or inert gas
- d) Materials :** EPDM / PTFE (recommended)
FPM / NBR (not recommended)

7.4. PUMP DISASSEMBLY

The assembly and disassembly of the pumps should only be done by qualified personnel. Make sure that the personnel read carefully this instruction manual and, in particular, those instructions which refer to the work they will perform.



Incorrect assembly or disassembly may cause damage in the pump's operation and lead to high repair costs and a long period of down-time. MOVEX is not responsible for accidents or damages caused by a failure to comply with the instructions in this manual.

Preparations

Provide for a clean working environment as some parts, including the mechanical seal, require very careful handling and others have close tolerances.

Check that the parts which are used are not damaged during transport. When doing this, you need to inspect the adjustment edge, the butted faces, the tight fit, burrs, etc.

After each disassembly, carefully clean the parts and check for any damage. Replace all damaged parts.

Tools

Use the proper tools for assembly and disassembly operations. Use them correctly.

Cleaning

Before disassembling the pump, clean it on the outside and on the inside.



NEVER clean the pump by hand when it is running

7.4.1. Pump cover disassembly



CAUTION! Liquid may spill from the rotor case when removing the pump cover.

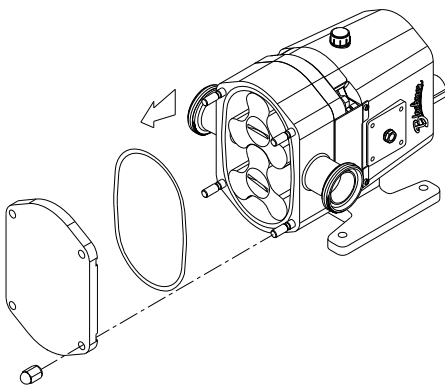

- Close the suction and delivery valves.
- Remove the cap nuts (45). Indents have been provided at four points around the perimeter of the pump cover (03) to assist, if necessary, in removing it from the rotor case (that is, with the help of a screwdriver).
- Check that the seal (80A) is in good condition.

7.4.2. Lobe disassembly

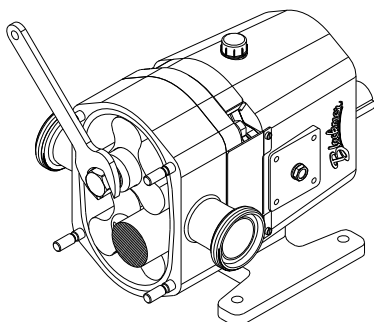

- Loosen the lobe screws (25) using a spanner (this spanner can be requested from MOVEX. See parts list).
- These screws have a right-hand thread. In order to prevent the lobes from turning simultaneously, blocks of wood or plastic can be placed between the lobes.
- Check that the O-ring (80) is in good condition.
- Remove both lobes (02). If necessary, use a tool to assist for this purpose.

7.4.3. Seal cover disassembly

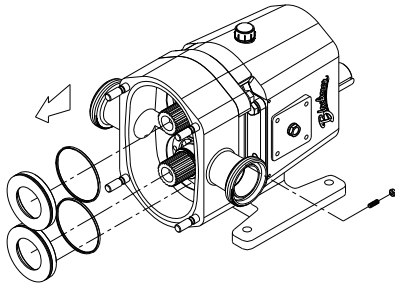

Pumps size 1:

- Due to its reduced size, this model does not incorporate a seal cover.

Pumps size 2, 3, 4, 5:

- Loosen the nuts (57) with which each seal cover (09) is fixed but ensure that these nuts remain a few thread tracks into the stud.
- Apply pressure to the nuts (57) to loosen the seal covers (09). If necessary, use a tool to assist for this purpose.
- When the nuts (57) have been removed, the seal covers can be removed (09). The fixed part (07) of the mechanical seals remains housed in the seal cover. The rotary part (01) remains mounted on the pump shafts.
- If there are any, remove the shims (32) mounted on each shaft. If more than one is mounted on each shaft, keep them separate to prevent them from getting mixed up.

7.4.4. Disassembly of mechanical seals

Pumps size 2, 3, 4, 5

As a result of the pump design, it is not necessary to disassemble the rotor case (01) in order to assemble/disassemble the mechanical seals.

Pumps size 1

Due to the reduced size of the pump, it is necessary to disassemble the rotor case before accessing the mechanical seals.

Consult section [7.7 Assembly and Disassembly of the Mechanical Seals](#)

7.4.5. Rotor case disassembly

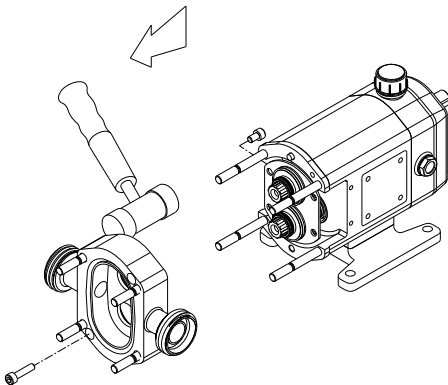

Pumps size 1:

- Remove the Allen screws (51B) that fix the rotor case to the gear case (06).
- Remove the rotor case (01) using a nylon hammer if necessary.

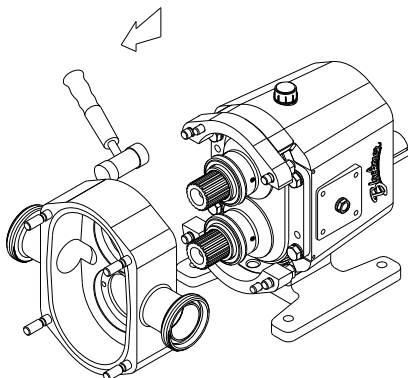

Pumps size 2, 3, 4, 5:

- Loosen and remove the nuts (54A) that fix the rotor case (01) to the gear case (06).
- Remove the rotor case (01) using a nylon hammer if necessary.

7.4.6. Lubrication oil drainage

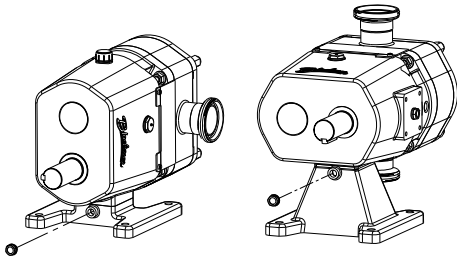

- Place a container underneath the gear case (06) to collect the lubricant oil so that it can be recycled.
- Remove the drainage plug (87) located at lower rear side of the pump base (07).

7.4.7. Shaft Assembly Removal

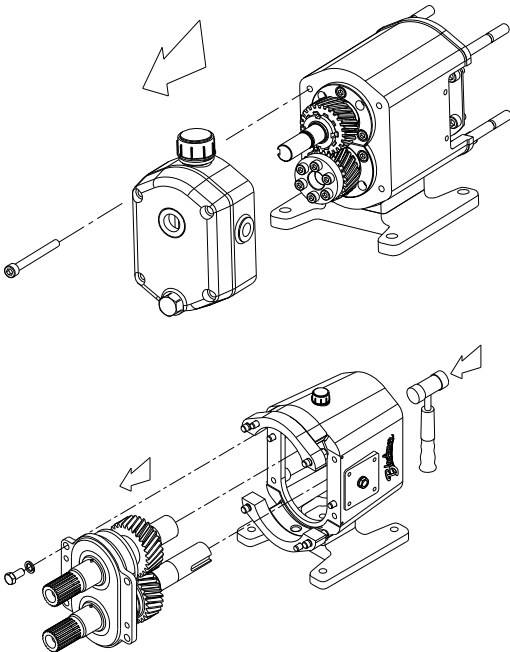

Pumps size 1:

- Remove the key (61A) from the driveshaft (05).
- Remove the screws (51D) and dismount the rear cover (12B) while checking that the O-ring (80E) does not stick to both sides.

Pumps size 2, 3, 4, 5:

- Identify the position of the driveshaft (05) and whether it is in the up or down position.
- Remove the screws (52) and washers (53A) that fix the bearings cover (12) to the gear case (06).
- Remove the key (61) from the driveshaft (05).
- Remove the shaft assembly from the gear case. Due to the tightness of the bearings cover (12), a nylon hammer must be used. Lightly tap the rear part of the driveshaft (05).
- Check the condition of the Klingerit seal (18A) once the shaft assembly has been removed, and if there are any defects, find a replacement before reassembling the pump.

7.5. PUMP ASSEMBLY

7.5.1. Shaft Assembly

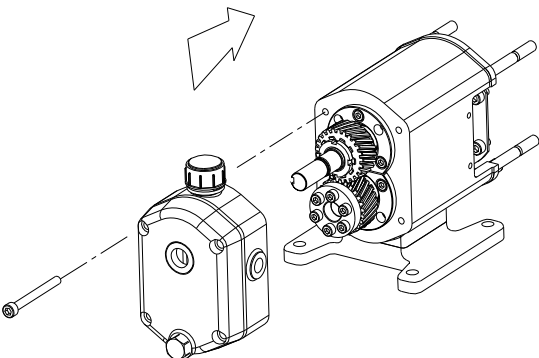

Pumps size 1:

- Check that the O-ring (80E) has not been damaged and attach it with a little grease or oil in the correct position of the bottom cover (12B).
- Attach the rear cover and fix it on with screws (51D).
- Place the key (61A) in the driveshaft (05).

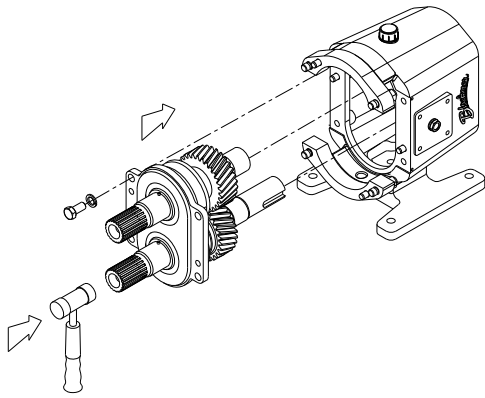

Pumps size 2, 3, 4, 5:

- Ensure that the Klingerit seal (18A) - in the case of pump size 4 check the O-ring (80E) - is in good condition, or if necessary replace it with a new one, and fit it to the gear case (06).
- Make sure to reassemble the pump with the driveshaft (05) in the up or down position just as it was before disassembling.
- Introduce the shaft assembly into the gear case (06) taking care when sliding the shaft (05) driven by the retainer (88).
- Use a nylon hammer and lightly tap the shafts (05 and 05A) until the bearings cover (12) is well fixed to the gear case (06).
- Fix the bearings cover (12) to the gear case (06) with the washers and screws (53A and 52).
- Place the key (61A) in the driveshaft (05).

7.5.2. Filling with Lubricant Oil

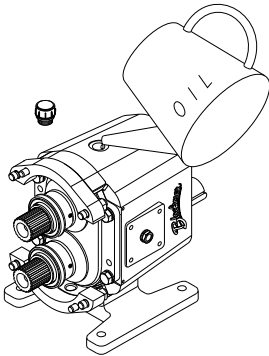

- Remove the oil plug (85) located at the top of the gear case (06).
- Fill the gear case (06) with lubricant according to the instructions given in chapter 7.1.3.

7.5.3. Rotor case assembly



CAUTION! When reassembling the rotor case, pay attention to the position of the centering pins.

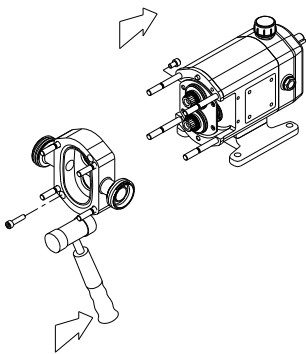

Pumps size 1:

- Mount the rotor case (01) on the gear case (06). Due to the tightness of the pins, it is necessary to use a nylon hammer. Lightly tap the rotor case until it is tight to the gear case.
- Attach the nuts (54A) with the washers (53).
- Tighten the nuts with the appropriate tightening torque.

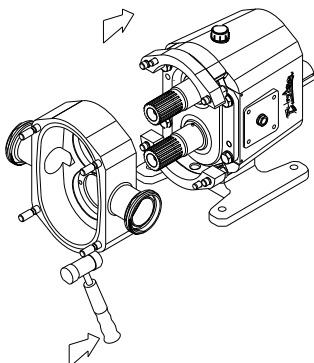

Pumps size 2, 3, 4, 5:

- Mount the rotor case (01) on the gear case (06). Due to the tightness of the pins, it is necessary to use a nylon hammer. Lightly tap the rotor case until it is tight to the gear case.
- Attach the nuts (54A) with the washers (53).
- Tighten the nuts with the appropriate tightening torque.

7.5.4. Seal cover assembly

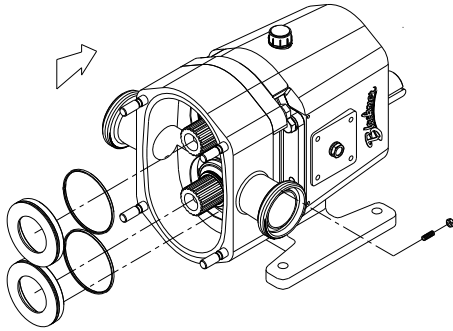

Pumps size 1:

- Due to its reduced size, this model does not incorporate a seal cover.

Pumps size 2, 3, 4, 5:

- Check the condition of the O-rings (80B).
- Lubricate the rings (80B) with soapy water or edible oil compatible with the material of the O-rings, pumped liquid and application.
- Mount the seal covers (09) on the rotor case (01).
- Tighten the self-locking nuts (57) to the studs of the seal cover (09).

7.5.5. Lobe assembly



ALWAYS check the clearance between the lobes and lobes and rotor case before finishing assembly.
See 7.6.1 Clearance and tolerance table

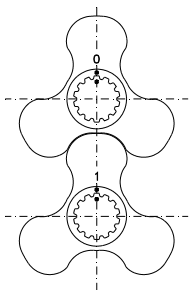

Pumps size 2, 3, 4, 5

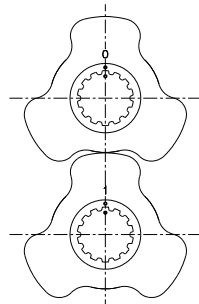

Pumps size 1

- Fit new O-rings (80) to the lobe screws (25)
- Lubricate the rings with soapy water or edible oil compatible with the material of the O-rings, pumped liquid and application.
- If any, replace the appropriate shims (32) on each shaft. Do not forget to check the clearance between lobe and housing (refer to chapter 7.6.).
- Place the lobes (02) on the shafts (05 and 05A) ensuring that the lobe and shaft markings (numbers 0 and 1) coincide.
- Tighten the screws (25) using a spanner. In order to prevent the lobes from turning simultaneously, blocks of wood or plastic can be placed between the lobes.
- Assembly is exactly the same for all lobe types.

7.5.6. Pump cover assembly

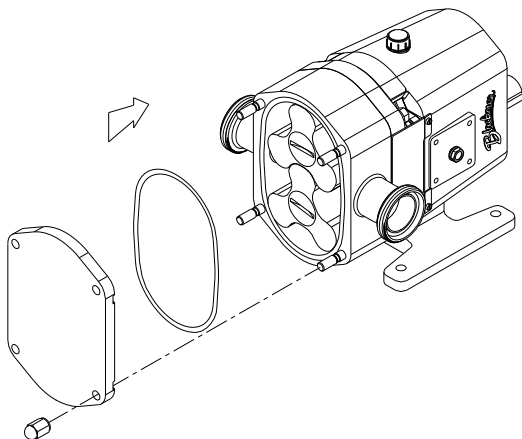

- Check that the O-ring (80A) is in good condition or, if applicable, replace it with a new one.
- Place it in the rotor case (01) ensuring that no dirt or residue of any product remains in the seal or the rotor case.
- If it is necessary to lubricate the O-ring to assist in fitting it, use soapy water or edible oil compatible with the material of the O-ring, pumped liquid and application.
- Place the pump cover (03) onto the rotor case (01) and tighten the blind nuts (45).
- See chapter 5.1.1 [Checks to be carried out before putting the pump into operation](#)

7.6. LOBE ADJUSTMENT

7.6.1. Clearance and tolerance table

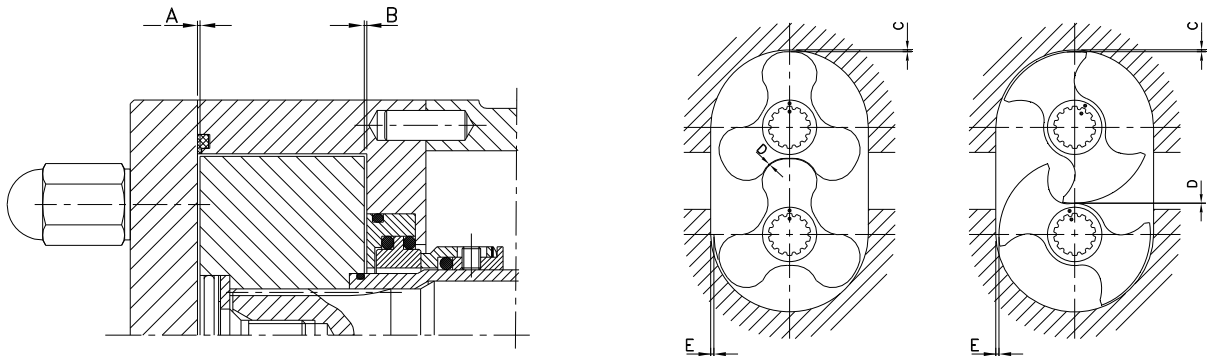

(mm)	A	B	C	D	E
BLK 1-2-12	0,12 ±0,05	0,07 ±0,03	0,15 ±0,05	0,15 ±0,05	0,35 ±0,05
BLK 1-2-7	0,15 ±0,05	0,08 ±0,03	0,2 ±0,05	0,15 ±0,05	0,4 ±0,05
BLK 2-6-12	0,15 ±0,05	0,1 ±0,05	0,15 ±0,05	0,15 ±0,05	0,35 ±0,05
BLK 2-8-7	0,15 ±0,05	0,1 ±0,05	0,2 ±0,05	0,15 ±0,05	0,4 ±0,05
BLK 3-13-12	0,2 ±0,05	0,15 ±0,05	0,15 ±0,05	0,15 ±0,05	0,35 ±0,05
BLK 3-17-7	0,2 ±0,05	0,15 ±0,05	0,2 ±0,05	0,15 ±0,05	0,4 ±0,05
BLK 4-29-12	0,25 ±0,05	0,2 ±0,05	0,2 ±0,05	0,2 ±0,05	0,4 ±0,1
BLK 4-41-7	0,3 ±0,05	0,2 ±0,05	0,3 ±0,1	0,2 ±0,05	0,5 ±0,1
BLK 5-78-12	0,3 ±0,05	0,3 ±0,05	0,4 ±0,1	0,3 ±0,05	0,85 ±0,1
BLK 5-116-7	0,45 ±0,05	0,35 ±0,05	0,6 ±0,1	0,3 ±0,05	1,05 ±0,1

A = axial clearance between the lobe and the cover.

B = axial clearance between the lobe and the rear of the rotor case.

C = radial clearance between the lobe and the rotor case.

D = radial clearance between the lobes.

E = radial clearance between the lobe and the rotor case on the suction side.

Dimensions in mm

7.6.2. Synchronizing the lobes

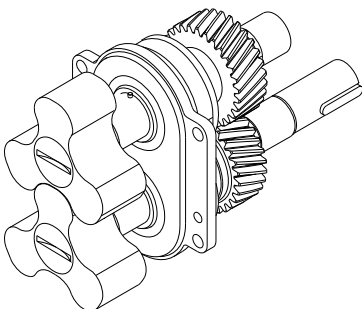

- In order to enable the lobes to be tightened, it is necessary to remove the shaft assembly from the gear case (except in the case of pump size 1), and mount the lobes (02) on the shafts fixing them with screws (25).

- Loosen the tightening screws from the adjustable fastening mechanism for the idler gear (19A). In principle, the adjustable fastening mechanism is easy to disassemble. It is now possible to rotate the driveshaft (05) while holding the idler shaft still (05A).

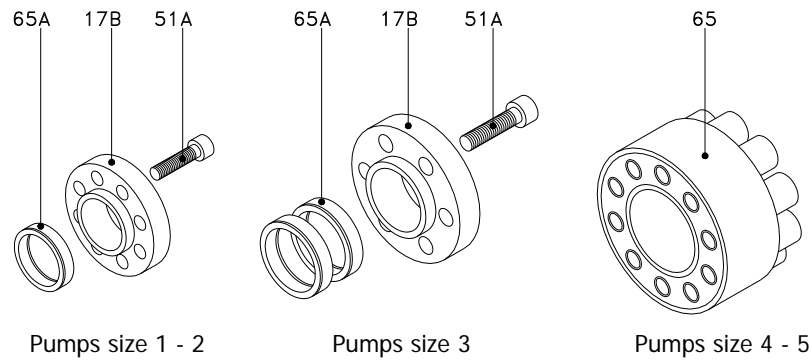

Pumps size 1 - 2 - 3: the adjustable fixing mechanism consists of three pieces: Allen screws (51A), bearing cones (65A), and impeller bushing (17B).

Pumps size 4 - 5: the adjustable fixing mechanism is a single piece (65).

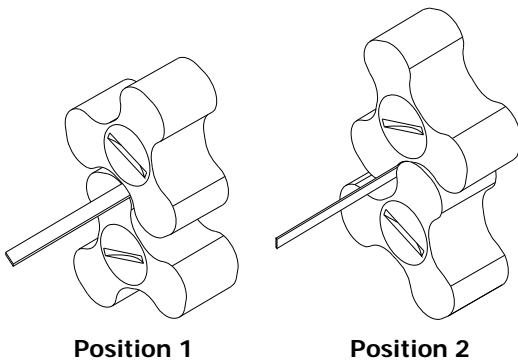

- Slide the lobes (25) over the shafts (05 and 05A) as indicated in 7.5.5 [Lobe assembly](#).
- Turn the lobes to the position indicated in position 1 until the gap is as indicated in 7.6.1. [Clearance and tolerance table](#).
- Tighten manually several tightening screws in the adjustable fixing mechanism.
- Then turn the upper lobe about 60° to the left (position 2). Check that the gap in this position is equal to the position. If not, these gaps should be equalized by turning one lobe slightly while holding the other still.

- Tighten the tightening screws of the adjustable fixing mechanism diagonally by 2 or 3 turns with the established tightening torque.
- When tightening the screws of the adjustable fixing mechanism (51A), ensure that the gears (19 and 19A) do not turn in relation to each other. This can be avoided by placing a wooden wedge between the gears (19 and 19A).
- Check again the gap between the lobes (02) and turn the driveshaft (05) a few times in order to check that the lobes (02) do not rub against one another at any point.
- Remove the lobes (02) from the shafts (05 and 05A).
- Apply a little lubricant to the driveshaft (05) at the location of the retainer (88) once assembly is finished.

7.6.3. Lobe/Rotor case adjustment using shims

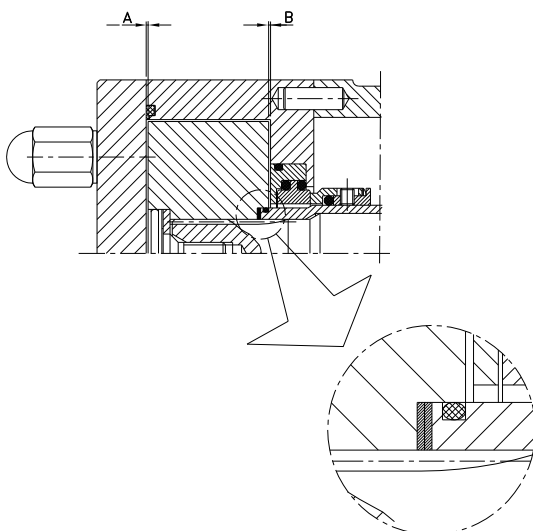

- This is the final adjustment to be carried out. The pump must be synchronized and the rotor case must be mounted on the gear case.

Pumps size 1:

- Due to its small size, and the low assembly tolerances, this pump does not use shims. The length of the sleeves (13) must be adjusted for each pump.

Pumps size 2, 3, 4, 5:

- The adjustment is made using ring-shaped shims (32) placed between the sleeve (13) and the lobe (02).
- There are 3 different shim thicknesses (0.05, 0.1, and 0.2 mm).
- Assemble a complete set of shims for each lobe, and place the seal cover (29) to the rotor case (01).
- Mount the lobes (02) and tighten the screws (25) as described in 7.5.5. [Lobe assembly](#).
- Check the tolerances between the lobe and rotor case (A and B). See 7.6.1. [Clearance and tolerance table](#). If they are out of range, change the shims until the necessary clearance is achieved.

7.7. MECHANICAL SEAL ASSEMBLY AND DISASSEMBLY

7.7.1. Single mechanical seal



Mechanical seals are fragile parts. Take care when handling them.

- Clean all the components of the mechanical seal before placing them.
- Check that the working surfaces are not damaged. MOUVEX recommends replacing the entire mechanical seal if one of the working surfaces has a defect.
- Replace the O-rings during assembly.

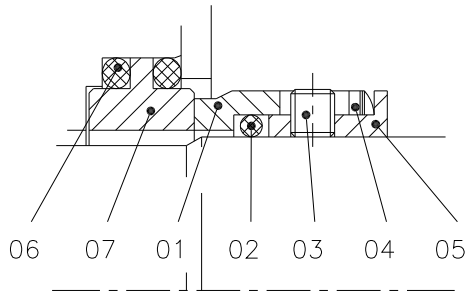

Pos.	Description
	Single mechanical seal
01	Rotary part
02	O-ring
03	Fixing stud
04	Crimped spring
05	Drive ring
06	O-ring
07	Stationary part

Disassembly

- Normally the fixed part (07) and the O-rings (06) remain housed in the seal cover (09) during disassembly. Remove them carefully.
- Separate the adjustment shims (32) housed behind the fixed part.
- Remove the rotary parts (01 + 05) from the shafts along with the sleeves (13).
- Loosen the studs (03).
- Disassemble the rotary part from each sleeve (13).

Assembly



Remember, if there are any, fit the shims (32) on each origin shaft.

- Lubricate all the O-rings of the mechanical seal with soapy water or edible oil compatible with the material of the seals, pumped liquid and application.
- Mount the rotary parts (01) on the sleeves (13) while maintaining **length A** as indicated in the table.
- Mount the sleeves (13) onto the pump shafts (05 and 05A) as far as they will go.
- If there were any adjustment shims (32), fit them into the seal cover (09).
- Mount the fixed part (07) to the seal cover (09) ensuring that it remains perfectly flat.
- Clean the working surfaces with solvent.
- Reassemble the seal cover (09) according to 7.5.4 [Seal Cover Assembly](#)
- See paragraph 7.6.3 [Lobe/Rotor case adjustment using shims](#)

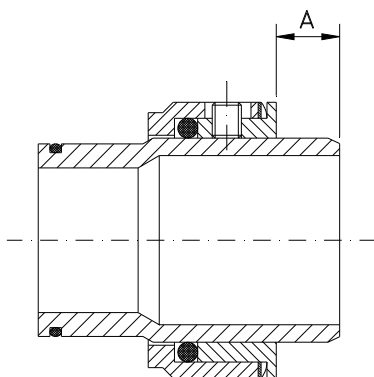

Model	A (mm)
BLK 1-2-12 / 1-2-7	8
BLK 2-6-12 / 2-8-7	9,5
BLK 3-13-12 / 3-17-7	11
BLK 4-29-12 / 4-41-7	20
BLK 5-78-12 / 5-116-7	-

7.7.2. Double mechanical seal

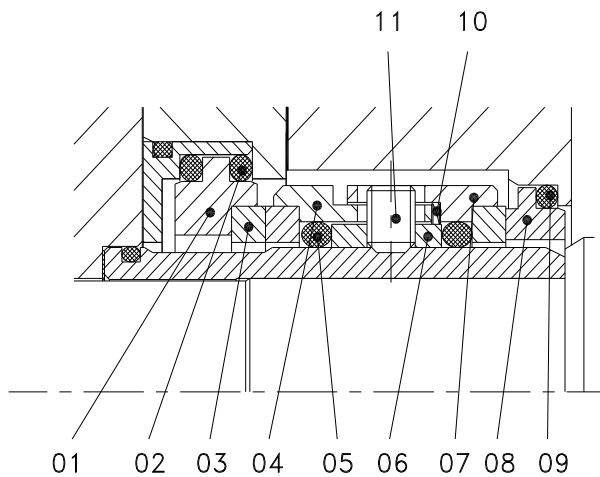

Pos.	Description
	Double mechanical seal
01	Static face
02	O-ring
03	Insert
04	Rotary holder
05	O-ring
06	Drive ring
07	Rotary holder
08	Static face
09	O-ring
10	Wave spring
11	Fixing stud



Mechanical seals are fragile parts. Take care when handling them. Do not use any screwdriver or similar tool to pull out the parts.

- Clean all the components of the mechanical seal before placing them.
- Check that the working surfaces are not damaged. MOUVEX recommends replacing the entire mechanical seal if one of the working surfaces has a defect.
- Replace the O-rings during assembly.

Disassembly



If there are any, remove the shims (32) mounted on each shaft. If more than one is mounted on each shaft, keep them separate to prevent them from getting mixed up.

- Normally the fixed part (01) and the O-rings (02) remain housed in the seal cover (09) during disassembly. Remove them carefully. Also the fixed part (08) and the O-ring (09) remain housed in the double mechanical seal cover (10B).
- Separate the adjustment shims (32) housed behind the fixed part.
- Remove the rotary parts (04 + 07) from the shafts along with the sleeves (13).
- Loosen the studs (11).
- Disassemble the rotary part from each sleeve (13).
- If it is necessary to remove the fixed part (08) and O-ring (09), disassembly the rotor case according to 7.4.5 [Rotor case disassembly](#).
- Disassembly the double mechanical seal cover and remove the fixed part (08) and O-ring (09) carefully.

Assembly



Remember, if there are any, fit the shims (32) on each origin shaft.

- Lubricate all the O-rings of the mechanical seal with soapy water or oil compatible with the material of the seals.
- Mount the fixed part (08) on the double mechanical seal cover ensuring that it remains perfectly flat.
- Clean the working surfaces with solvent.
- Reassembly the double mechanical seal cover with the rotor case.
- Reassembly the rotor case with the gear case according to 7.5.3 [Rotor case assembly](#).
- Mount the rotary parts (04 + 07) on the sleeves (13).
- Mount the sleeves (13) onto the pump shafts as far as they will go.
- If there were any adjustment shims (32), fit them into the seal cover (09).
- Mount the fixed part (01) to the seal cover (09) ensuring that it remains perfectly flat.
- Clean the working surfaces with solvent.
- Reassemble the seal cover (09) according to 7.5.4 [Seal Cover Assembly](#).
- See paragraph 7.6.3 [Lobe/Rotor case adjustment using shims](#).

8. Technical Specifications

8.1. TECHNICAL SPECIFICATIONS

	Short rotor	Long rotor
Theoretical displacement volume x 100 rev.	217 L	321 L
Maximum theoretical flow rate.....	78 m ³ .h ⁻¹ (343 gpm)	115 m ³ .h ⁻¹ (510gpm)
Maximum differential pressure.....	12 bar (174 psi)	7 bar (102 psi)
Maximum working pressure.....	16 bar (232 psi)	16 bar (232 psi)
Maximum temperature ⁽¹⁾	110°C (230°F)	110°C (230°F)
Maximum viscosity ⁽²⁾ (recommended).....	100.000 mPa.s	100.000 mPa.s
Maximum speed	950 rpm	950 rpm
Maximum connections diameter.....	100 mm (4 in)	150 mm (6 in)
Suction / delivery connections	DIN 11851 (standard)	DIN 11851 (standard)

⁽¹⁾ To consult for higher temperatures.

⁽²⁾ The maximum viscosity allowed will depend on the nature of the liquid and the sliding speed of the seal faces. Consult MOUVEX should the viscosity be still greater.



Use special protection when the noise level in the operation area exceeds 85 dB(A).

Pump size	n_{max} [rpm]	B_1 [mm]	D_1 [mm]	V_{s-100} [L]	Q_{th} [m ³ .h ⁻¹]	P_{max} [bar]	V_u [m.s ⁻¹]	V_i [m.s ⁻¹]
BLK 1-2-12	950	21	47,84	2,1	1,8	12	3,63	1,76
BLK 1-2-7	950	29	47,84	3,0	1,7	7	2,38	0,96
BLK 2-6-12	950	30	69,15	10,0	5,7	12	3,44	2,97
BLK 2-8-7	950	42	69,15	13,9	7,9	7	3,44	1,95
BLK 3-13-12	950	42	87,65	23,4	13,3	12	4,36	3,27
BLK 3-17-7	950	54	87,65	30,1	17,1	7	4,36	2,43
BLK 4-29-12	720	54	131,5	67,7	29,3	12	4,96	4,14
BLK 4-41-7	720	76	131,5	95,3	41,2	7	4,96	2,22
BLK 5-78-12	600	104	169,74	217,2	78,2	12	5,33	2,77
BLK 5-116-7	600	154	169,74	321,7	115,8	7	5,33	1,82

n_{max}	Maximum speed
B_1	Lobe width
D_1	Lobe diameter
V_{s-100}	Theoretical displacement volume x 100 rev
Q_{th}	Theoretical flow rate at n_{max}
P_{max}	Maximum differential pressure
V_u	Peripheral speed
V_i	Maximum inlet velocity

Materials

Parts in contact with pumped material	AISI 316L
Other parts in stainless steel	AISI 304
Gaskets in contact with pumped material	EPDM
Other materials for optional gaskets.....	Consult your supplier
Surface finishing	Standard finish

Mechanical seal

Type of seal	Single external mechanical seal
Stationary parts material	Carbon
Rotary parts material	Silicon carbide
Elastomers material	EPDM

Cooled mechanical seal

Working pressure	0,5 bar (7,2 psi)
Flow rate of the circulation	2,5-5 L.min ⁻¹ (0,7-1,3 gpm)

Double mechanical seal

Operating pressure	1,5-2 bar (22-29 psi) over the pump operating pressure
--------------------------	--

O-ring seal

Material.....	VITON [®] or EPDM
Maximum pressure	15 bar (218 psi)

PTFE lip seal

Material.....	PTFE + AISI 316
Maximum pressure	10 bar (145 psi)

Double lip seal

Material.....	VITON [®]
Maximum pressure	7 bar (102 psi)

Gland packing

Packing material	PTFE
Maximum pressure	10 bar (145 psi)

Heating jacket

Maximum temperature.....	110°C (230°F)
Maximum pressure	4 bar (58 psi)

Viton[®] is a registered trademark of DuPont Performance Elastomers.

8.1.1. Frame of the particles



WARNING! Only soft particles.
 < 10 % damage when using trilobe geometry.
 < 2 % damage when using wing lobe geometry.

Pump size	Internal diameter connection [mm]	Maximum theoretical sphere frame [mm]	Recommended maximum theoretical sphere frame [mm]
BLK 1-2-12	15,8	7,5	2,5
BLK 1-2-7	22,4	7,5	2,5
BLK 2-6-12	22,4	20,6	7
BLK 2-8-7	35,1	20,6	7
BLK 3-13-12	35,1	25,6	9
BLK 3-17-7	47,8	25,6	9
BLK 4-29-12	47,8	38,5	13
BLK 4-41-7	72,2	38,5	13
BLK 5-78-12	97,6	45,6	15
BLK 5-116-7	150	45,6	15

8.1.2. Torque

Maximum acceptable torque on the pump shaft

Gear Case	(N.m)
BLK 1	35
BLK 2	53
BLK 3	108
BLK 4	400
BLK 5	1200

8.2. WEIGHTS

Pump size	Pump with bare shaft end [kg]
BLK 1-2-12	12
BLK 1-2-7	13
BLK 2-6-12	16
BLK 2-8-7	17
BLK 3-13-12	26
BLK 3-17-7	28
BLK 4-29-12	61
BLK 4-41-7	65
BLK 5-78-12	163
BLK 5-116-7	178

8.3. BLK PUMP DIMENSIONS

BLK 1

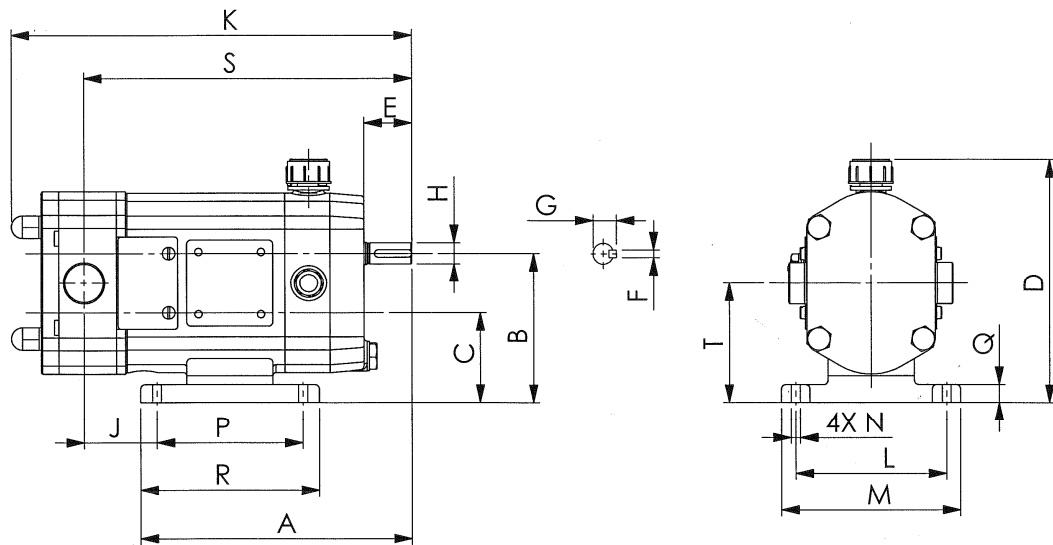

BLK 2-3-4-5

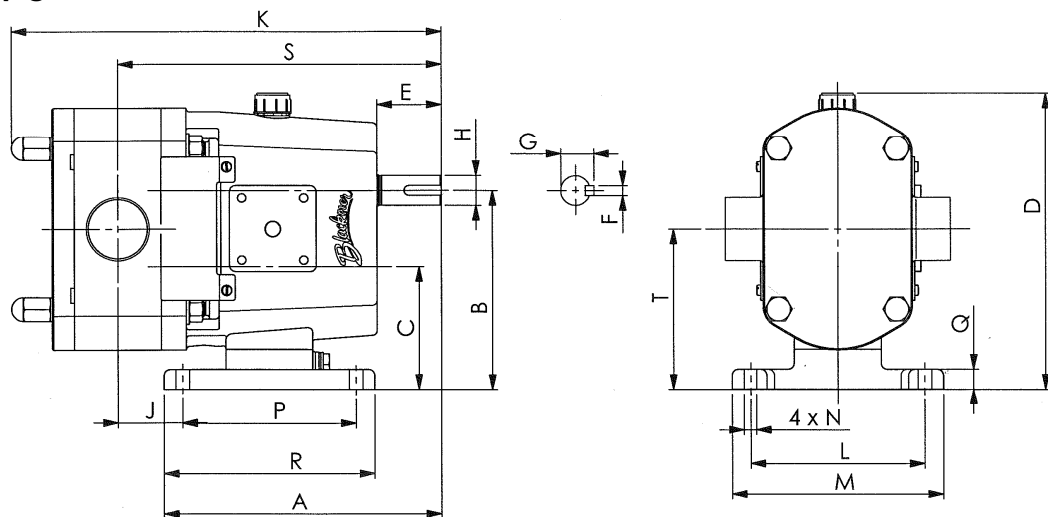

Pump	Dimensions																	
	A	B	C	D	E	F	G	H	J	K	L	M	N	P	Q	R	S	T
BLK 1-2-12	182	100	60	163	30	5	16	14	44	261	100	120	9	100	12	120	216	80
BLK 1-2-7									48	269							220	
BLK 2-6-12	184	140	90	208	40	6	21,5	19	42	280	120	145	9	120	14	145	213	115
BLK 2-8-7									48	292							219	
BLK 3-13-12	224	160	98	239	50	8	27	24	46	335	140	170	11	140	16	170	255	129
BLK 3-17-7									52	347							261	
BLK 4-29-12	305	210	117	303	80	10	41	38	57	428	170	210	13	170	20	210	342	164
BLK 4-41-7									70	450							355	
BLK 5-78-12	428	270	150	393	110	16	59	55	98	625	245	300	18	245	23	300	499	210
BLK 5-116-7									125	675							525	

Dimensions are in mm

8.4. BLK DIMENSIONS (VERTICAL INLETS)

BLK 1

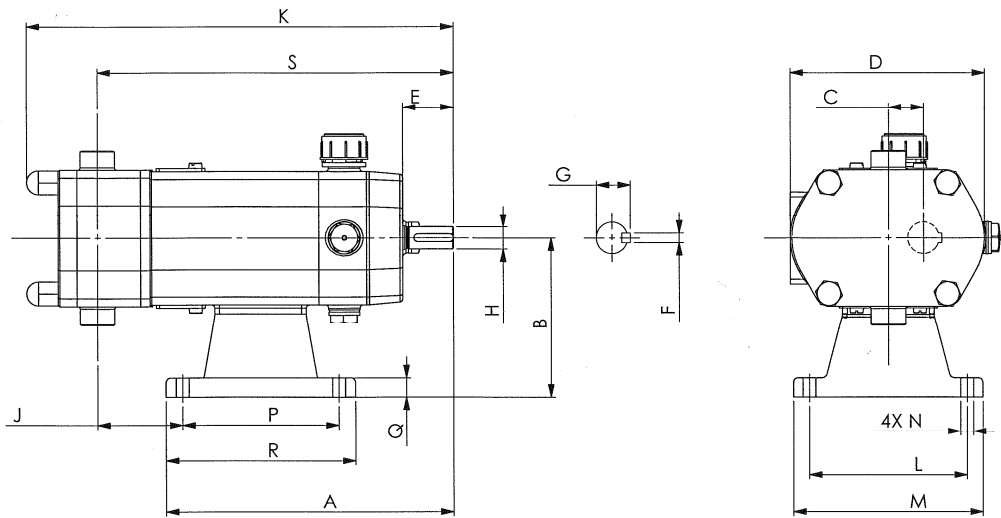

BLK 2-3-4-5

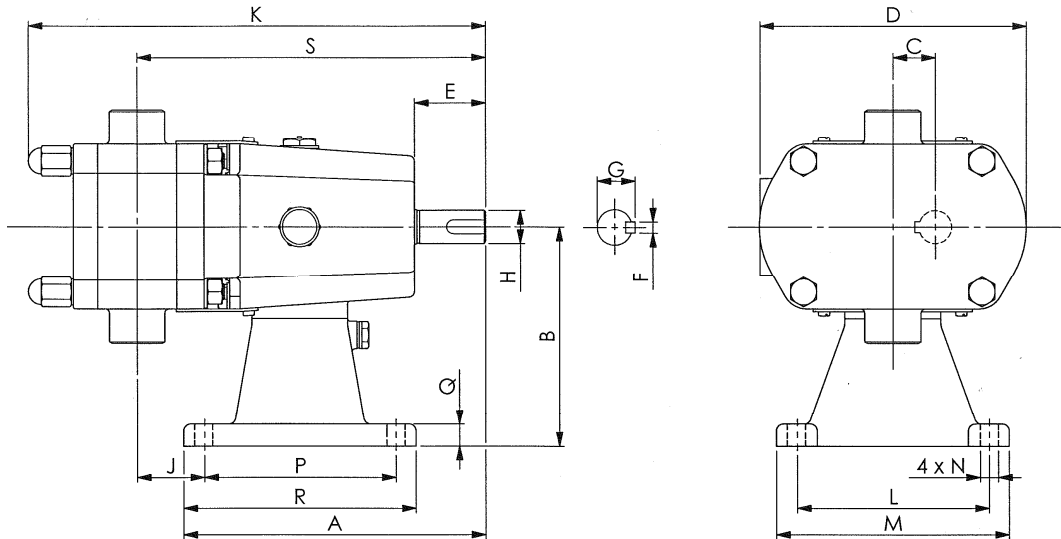

Pump	Dimensions																
	A	B	C	D	E	F	G	H	J	K	L	M	N	P	Q	R	S
BLK 1-2-12	182	100	20	123	30	5	16	14	44	261	100	120	9	100	12	120	216
BLK 1-2-7									48	269							220
BLK 2-6-12	184	140	25	163	40	6	21,5	19	42	280	120	145	9	120	14	145	213
BLK 2-8-7									48	292							219
BLK 3-13-12	221	160	31	195	50	8	27	24	46	335	140	170	11	140	16	170	255
BLK 3-17-7									52	347							261
BLK 4-29-12	305	210	47	255	80	10	41	38	57	428	170	210	13	170	20	210	342
BLK 4-41-7									70	450							355
BLK 5-78-12	428	270	60	344	110	16	59	55	98	624	245	300	18	245	23	300	499
BLK 5-116-7									125	674							525

Dimensions are in mm

8.5. DIMENSIONS PUMP WITH FLUSHING AND/OR SEALING HEATING JACKET AND FRONT HEATING JACKET

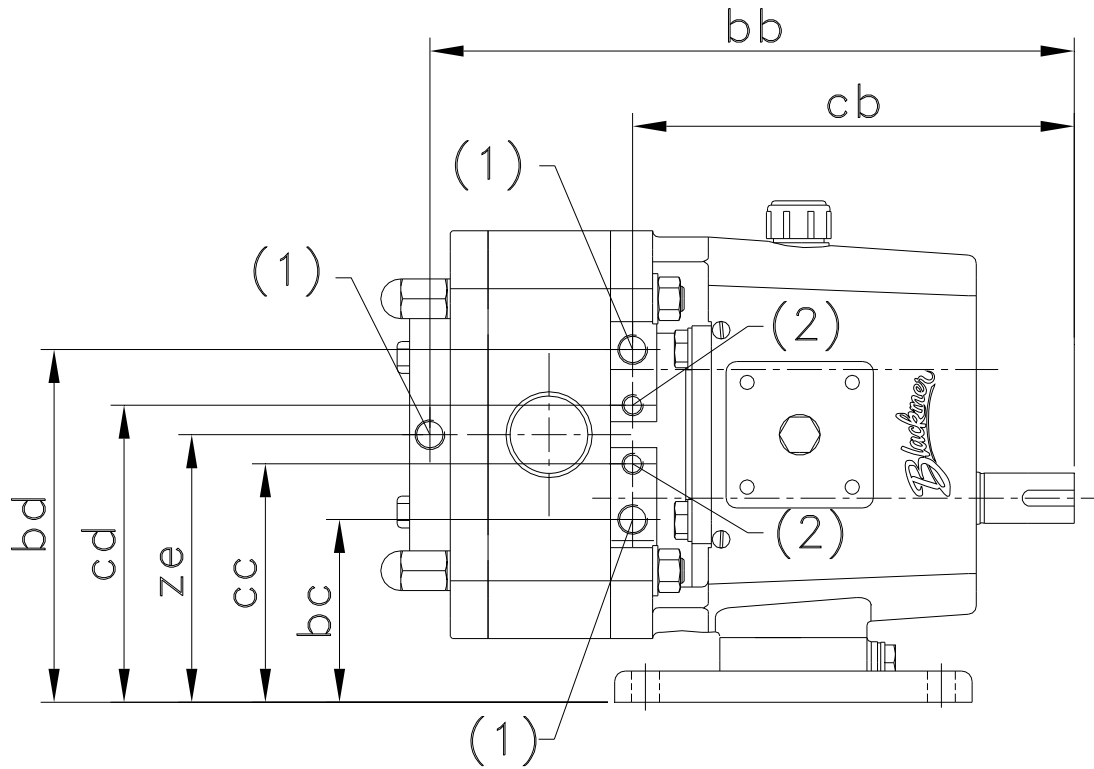

- (1) Heating jacket connection 6 x R1/4"
- (2) Flushing sealing connection 4 x R1/8"

Pump size	bb	bc	bd	cb	cc	cd	ze
BLK 1-2-12	252	-	-	190	70	90	80
BLK 1-2-7	261						
BLK 2-6-12	263	-	-	182	100	130	115
BLK 2-8-7	275						
BLK 3-13-12	314	84,5	163,5	216	109	149	129
BLK 3-17-7	326						
BLK 4-29-12	407	102	225	295	132	195	163,5
BLK 4-41-7	429						
BLK 5-78-12	562	137	283	389	180	240	210
BLK 5-116-7	612						

8.6. DIMENSIONS U

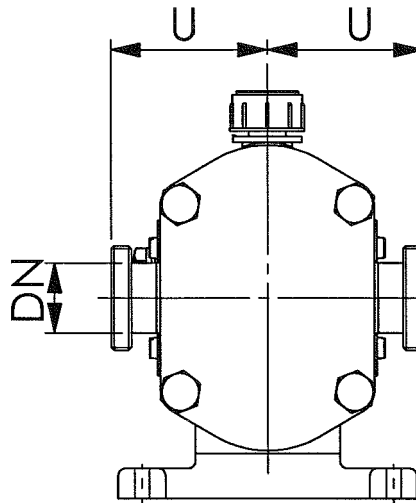

Pump	DN	U					
		DIN 11851	ISO 2852 (Clamp)	ISO 2853 (IDF)	BS4825-5 (RJT)	DIN 11864 BF-A	SMS1145
BLK 1-2-12	20 (¾")	79	67,5	-	-	80,5	-
BLK 1-2-7	25 (1")	77	76,5	76,5	76,5		74
BLK 2-6-12	25 (1")	94,5	94,5	94	94	98	91,5
BLK 2-8-7	40 (1½")						95,5
BLK 3-13-12	40 (1½")	107	106	106,5	106,5	110,5	108
BLK 3-17-7	50 (2")	108					
BLK 4-29-12	50 (2")	135,5	133,5	134	134	138	135
BLK 4-41-7	80 (3")	137,5				140	139,5
BLK 5-78-12	100 (4")	170	161,5	161,5	162	167,5	170
BLK 5-116-7	150 (5")	180	168	-	-	169,5	-

Except where indicated, dimensions are in mm

8.7. DIMENSIONS RECTANGULAR INLET

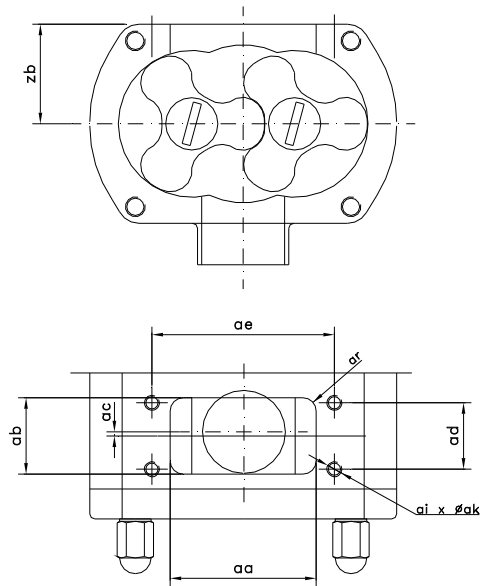

Pump size	aa	ab	ac	ad	ae	ar	ai x ϕ ak	zb
BLK 2-6-12	64	23	3,5	21	88	5	4 x M8	52,5
BLK 2-8-7		35		33				
BLK 3-13-12	86	34	4	33	108	10	4 x M8	60
BLK 3-17-7		46		40				
BLK 4-29-12	115	46	4	28	140	10	4 x M10	87,5
BLK 4-41-7		66		50				
BLK 5-78-12	158	90	3	70	198	15	4xM12	110
BLK 5-116-7		140		120				

Dimensions are in mm

8.8. DIMENSIONS FLANGE CONNECTIONS TO DIN 2633 PN 16 AND DIN 2634 PN 25

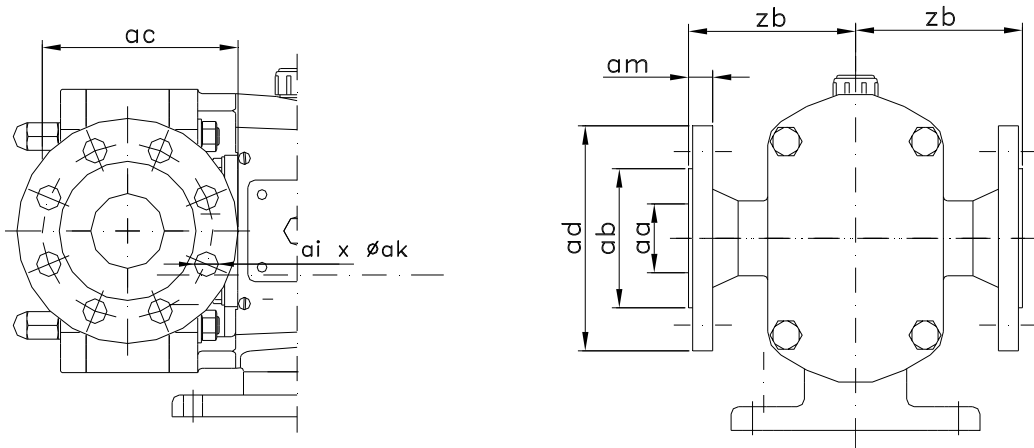

Pump size	DIN 2633 PN 16						
	aa	ab	ac	ad	ai x ϕ ak	am	zb
BLK 2-6-12	25	68	85	115	4 x 14	16	110,5
BLK 2-8-7	40	88	110	150	4 x 18		114,5
BLK 3-13-12	50	102	125	165		8 x 18	18
BLK 3-17-7					130		
BLK 4-29-12	80	138	160	200	8 x 18	20	157,5
BLK 4-41-7	100	158	180	220			162,5
BLK 5-78-12	100	158	180	220	8 x 23	22	192
BLK 5-116-7	150	212	240	285			195

Dimensions are in mm

8.9. BLK 1

8.9.1. Exploded view

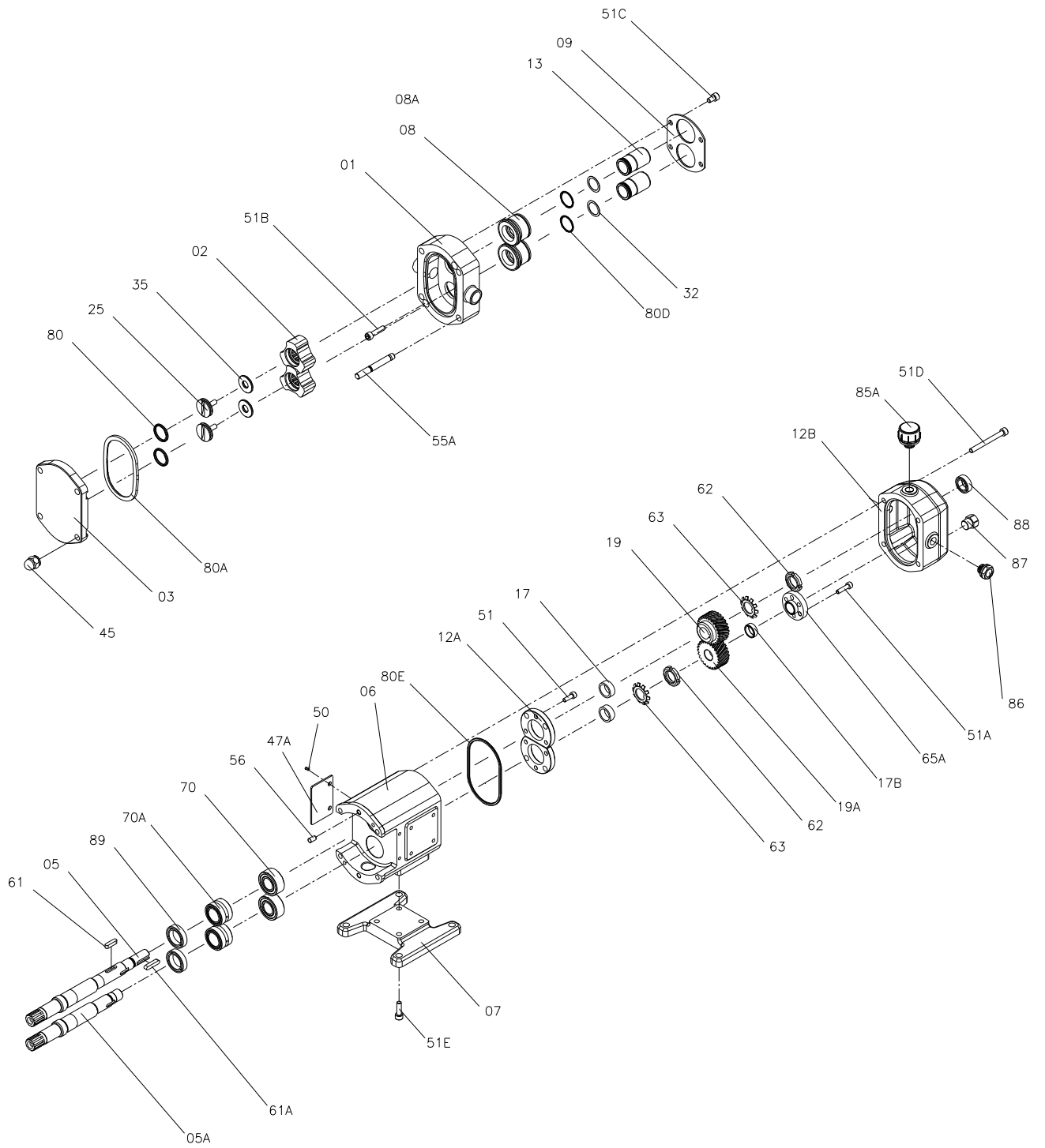

8.9.2. Spare parts

Pos.	Description	Quant.	Material
01	Rotor case	1	AISI 316L
	BLK 1-2-12 BLK 1-2-7		
02	Rotor	2	AISI 316L
	BLK 1-2-12 BLK 1-2-7		
03	Front cover	1	AISI 316L
05	Drive shaft	1	AISI 329
05A	Driven shaft	1	AISI 329
06	Gear case	1	GG-22
07	Support, horizontal ported	1	AISI 304
08	Mechanical seal, rotary part	2	SiI/70 EPDM
08A	Mechanical seal, stationary part	2	Graf/70 EPDM
09	Seal cover	1	AISI 316L
12A	Bearing cover	2	F-114
12B	rear cover	1	GG-22
13	Sleeve, seal	2	AISI 316L
17	Drive shaft bushing	2	F-114
17B	Lip seal bushing	2	F-114
19	Driver shaft gear	1	F-115
19A	Driven shaft gear	1	F-115
25	Lobe screw	2	AISI 316L
	BLK 1-2-12 BLK 1-2-7		
32	Shim	2	St. St.
35	Rotor washer	2	AISI 316L
45	Wing nut	4	AISI 304
47A	Protector	2	PET-Plus
50	Screw	4	A2
51	Allen screw	6	8.8
51A	Allen screw	6	8.8
51B	Allen screw	2	A2
51C	Allen screw	4	A2
51D	Allen screw	4	8.8
51E	Allen screw	2	8.8
55A	Stud	4	A2
56	Pin	2	F-522
61	Key	1	F-114
61A	Key	1	AISI 304
62	Safety nut	2	Steel
63	Safety washer	2	Steel
65A	Conical tightening ring	1	Steel
70	Roller bearings	2	Steel
70A	Needle bearings	2	Steel
80	O-ring	2	70 EPDM
80A	O-ring	1	70 EPDM
80D	O-ring	2	70 EPDM
80E	O-ring	1	70 MVQ
85	Oil plug	1	Plastic
86	Peephole	1	Plastic
87	Bleeder	2	Plastic
88	Lip seal	1	72 NBR
89	Lip seal	2	72 NBR

8.10. BLK 2

8.10.1. Exploded view

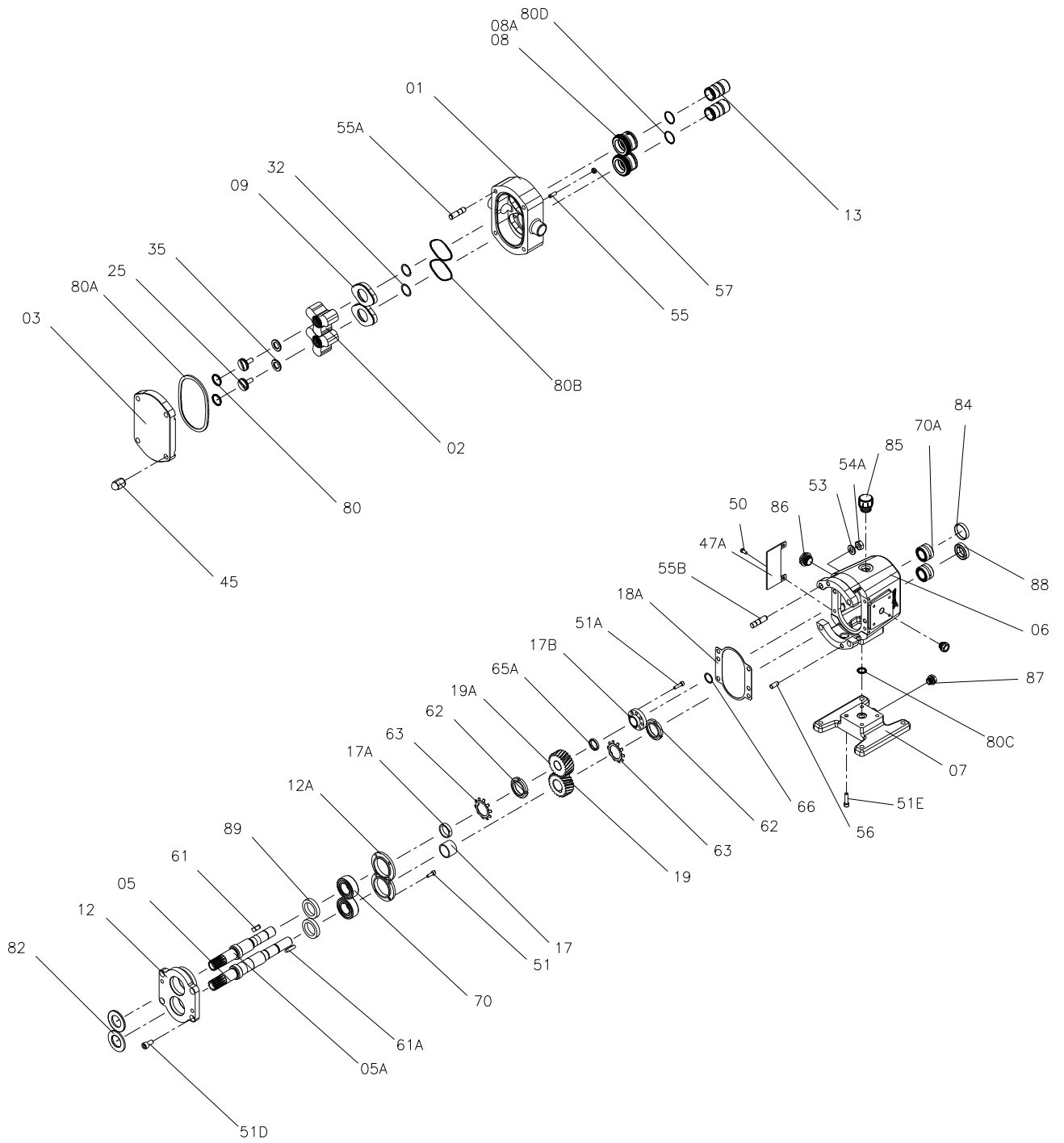

8.10.2. Spare parts

Pos.	Description	Quant.	Material
01	Rotor case BLK 2-6-12 BLK 2-8-7	1	AISI 316L
02	Rotor BLK 2-6-12 BLK 2-8-7	2	AISI 316L
03	Front cover	1	AISI 316L
05	Drive shaft	1	AISI-329
05A	Driven shaft	1	AISI-329
06	Gear case	1	GG-22
07	Support, horizontal ported	1	AISI 304
08	Mechanical seal, rotary part	2	-
08A	Mechanical seal, stationary part	2	-
09	Seal cover	2	AISI 316L
12	Bearing cover	1	GG-22
12A	Bearing stop flange	2	GG-22
13	Sleeve, seal	2	AISI 316L
17	Drive shaft bushing	1	ST-52
17A	Driven shaft bushing	1	ST-52
17B	Dragging bushing	1	ST-52
18A	Bearing cover gasket	1	Klingerit
19	Driver shaft gear	1	F-154
19A	Driven shaft gear	1	F-154
25	Lobe screw BLK 2-6-12 BLK 2-8-7	2	AISI 316L
32	Shim	2	St. St.
35	Rotor washer	2	AISI 316L
45	Wing nut	4	AISI 304
47A	Protector	2	Methacrylate
50	Screw	4	A2
51	Allen screw	8	8.8
51A	Allen screw	8	8.8
51D	Allen screw	4	8.8
51E	Allen screw	4	A2
53	Flat washer	4	A2
54A	Hexagonal nut	4	A2
55	Stud	4	A2
55A	Stud	4	A2
55B	Stud	4	A2
56	Pin	4	F-522
57	Self-locking nut	4	A2
61	Key	1	F-114
61A	Key	1	AISI 304
62	Safety nut	2	Steel
63	Safety washer	2	Steel
65A	Conical tightening ring	1	Steel
66	Circlip	1	Steel
70	Ball bearings	2	Steel
70A	Needle bearings	2	Steel
80	O-ring	2	-
80A	Front cover gasket	1	-
80B	O-ring	2	-
80C	O-ring	1	NBR
80D	O-ring	2	-
82	Splash ring	2	EPDM
84	Blanking plug	1	72 NBR
85	Oil plug	1	Plastic
86	Peephole	1	Plastic
87	Bleeder	2	Plastic
88	Lip seal	1	72 NBR
89	Lip seal	2	72 NBR

8.11. BLK 3

8.11.1. Exploded view

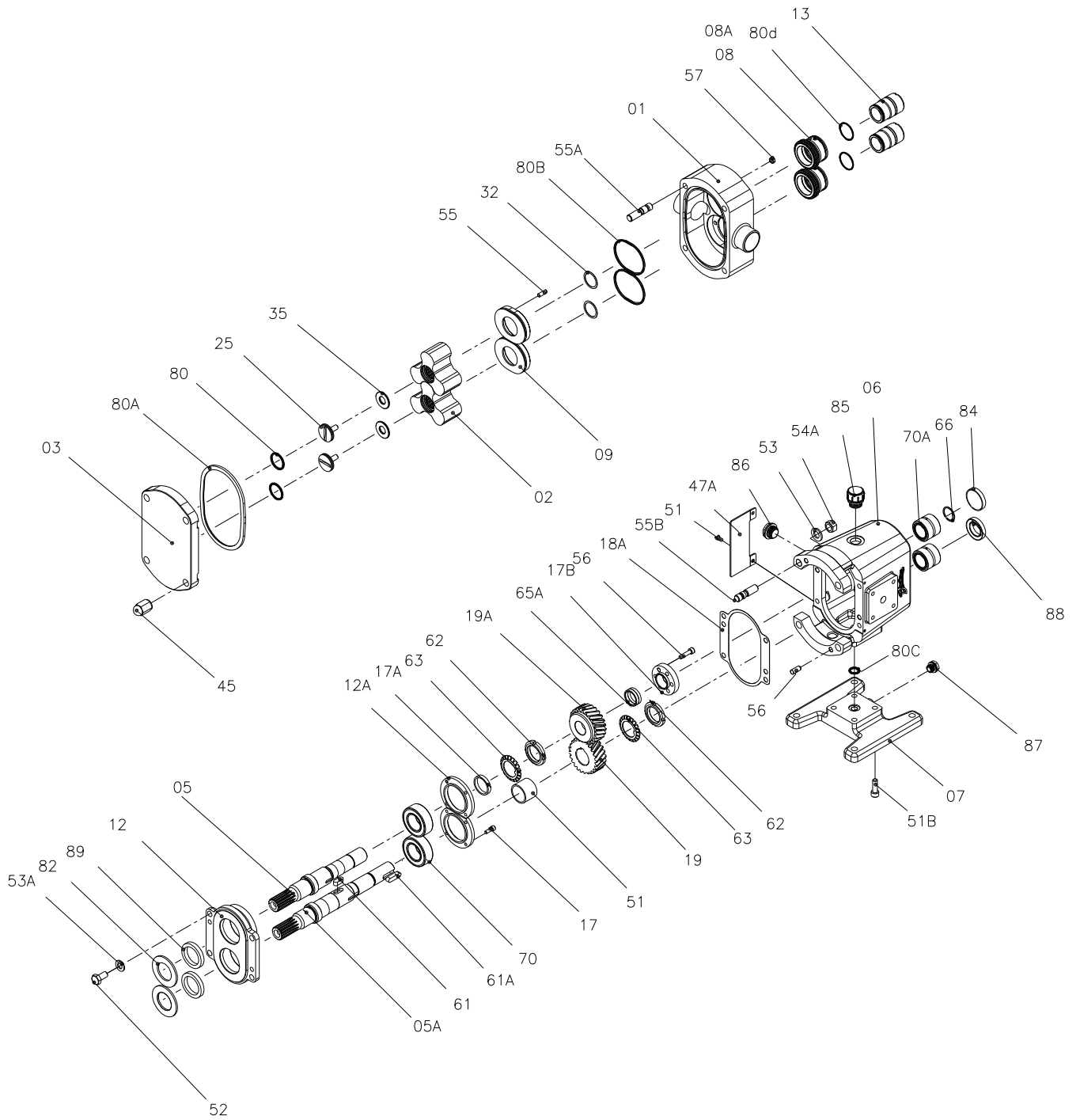

8.11.2. Spare parts

Pos.	Description	Quant.	Material
01	Rotor case BLK 3-13-12 BLK 3-17-7	1	AISI 316L
02	Rotor BLK 3-13-12 BLK 3-17-7	2	AISI 316L
03	Front cover	1	AISI 316L
05	Drive shaft	1	AISI 329
05A	Driven shaft	1	AISI 329
06	Gear case	1	GG-22
07	Support, horizontal ported	1	AISI 304
08	Mechanical seal, rotary part	2	-
08A	Mechanical seal, stationary part	2	-
09	Seal cover	2	AISI 316L
12	Bearing cover	1	GG-22
12A	Bearing stop flange	2	GG-22
13	Sleeve, seal	2	AISI 316L
17	Drive shaft bushing	1	ST-52
17A	Driven shaft bushing	1	ST-52
17B	Dragging bushing	1	ST-52
18A	Bearing cover gasket	1	Klingerit
19	Driver shaft gear	1	F-154
19A	Driven shaft gear	1	F-154
25	Lobe screw BLK 3-13-12 BLK 3-17-7	2	AISI 316L
32	Shim	2	St. St.
35	Rotor washer	2	AISI 316L
45	Wing nut	4	AISI 304
47A	Protector	2	Methacrylate
50	Screw	4	A2
51	Allen screw	8	8.8
51A	Allen screw	6	8.8
51E	Allen screw	4	A2
52	Hex. screw	4	8.8
53	Flat washer	4	A2
53A	Grower washer	4	Steel
54A	Hexagonal nut	4	A2
55	Stud	4	A2
55A	Stud	4	A2
55B	Stud	4	A2
56	Pin	4	F-522
57	Self-locking nut	4	A2
61	Key	1	F-114
61A	Key	1	AISI 304
62	Safety nut	2	Steel
63	Safety washer	2	Steel
65A	Conical tightening ring	1	Steel
66	Circlip	1	Steel
70	Ball bearings	2	Steel
70A	Needle bearings	2	Steel
80	O-ring	2	-
80A	Front cover gasket	1	-
80B	O-ring	2	-
80C	O-ring	1	NBR
80D	O-ring	2	-
82	Splash ring	2	EPDM
84	Blanking plug	1	72 NBR
85	Oil plug	1	Plastic
86	Peephole	1	Plastic
87	Bleeder	2	Plastic
88	Lip seal	1	72 NBR
89	Lip seal	2	72 NBR

8.12. BLK 4

8.12.1. Exploded view

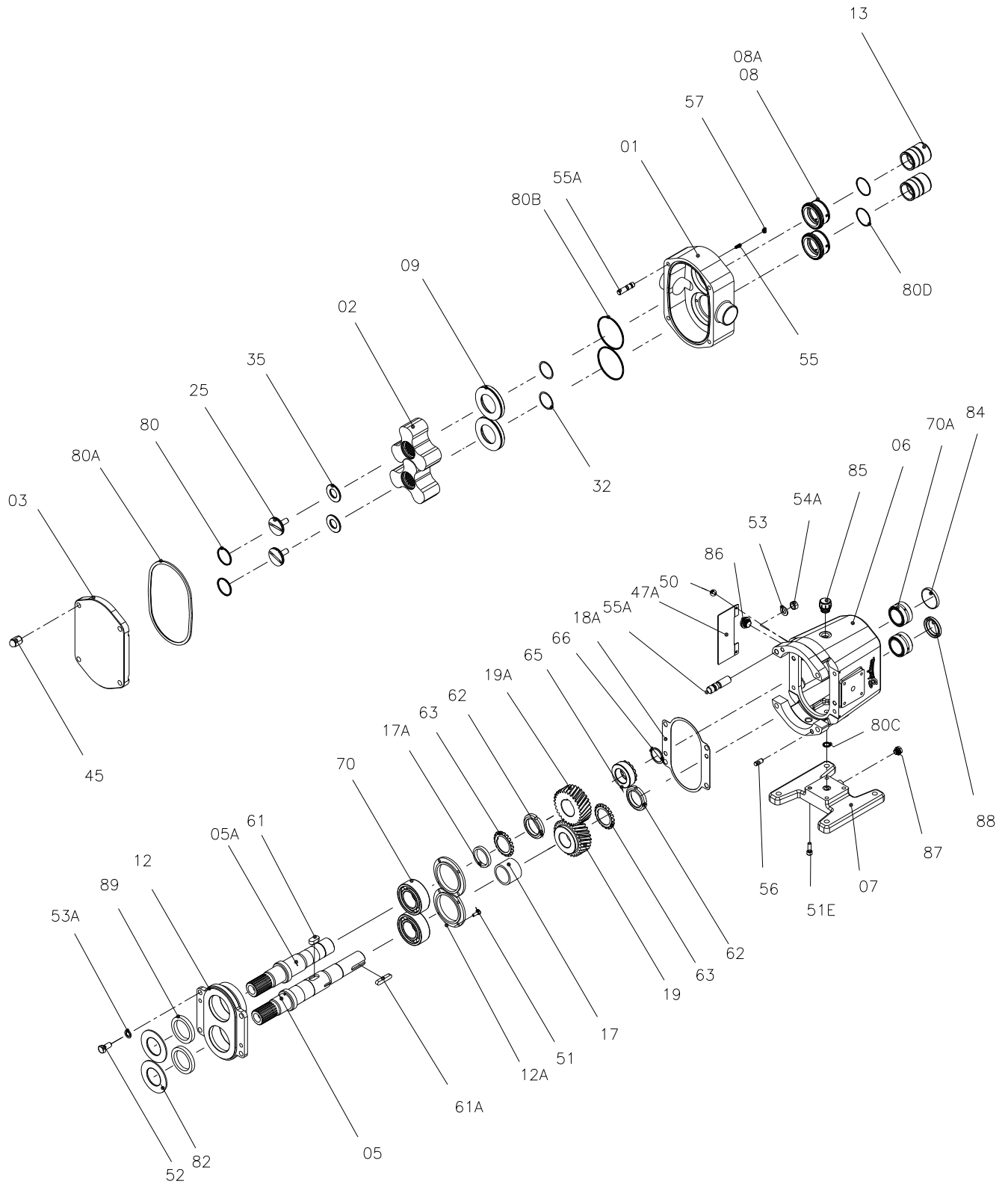

8.12.2. Spare parts

Pos.	Description	Quant.	Material
01	Rotor case BLK 4-29-12 BLK 4-41-7	1	AISI 316L
02	Rotor BLK 4-29-12 BLK 4-41-7	2	AISI 316L
03	Front cover	1	AISI 316L
05	Drive shaft	1	AISI 329
05A	Driven shaft	1	AISI 329
06	Gear case	1	GG-22
07	Support, horizontal ported	1	AISI 304
08	Mechanical seal, rotary part	2	-
08A	Mechanical seal, stationary part	2	-
09	Seal cover	2	AISI 316L
12	Bearing cover	1	GG-22
12A	Bearing stop flange	2	GG-22
13	Sleeve, seal	2	AISI 316L
17	Drive shaft bushing	1	ST-52
17A	Driven shaft bushing	1	ST-52
18A	Bearing cover gasket	1	Klingerit
19	Driver shaft gear	1	F-154
19A	Driven shaft gear	1	F-154
25	Lobe screw BLK 4-29-12 BLK 4-41-7	2	AISI 316L
32	Shim	2	St. St.
35	Rotor washer	2	AISI 316L
45	Wing nut	4	AISI 304
47A	Protector	2	Methacrylate
50	Screw	4	A2
51	Allen screw	8	8.8
51E	Allen screw	4	A2
52	Hex. screw	4	A2
53	Flat washer	4	A2
53A	Grower washer	4	Steel
54A	Hexagonal nut	4	A2
55	Stud	4	A2
55A	Stud	4	A2
56	Pin	4	F-522
57	Self-locking nut	4	A2
61	Key	1	F-114
61A	Key	1	AISI 304
62	Safety nut	2	Steel
63	Safety washer	2	Steel
65	Conical tightening ring	1	Steel
66	Circlip	1	Steel
70	Ball bearings	2	Steel
70A	Needle bearings	2	Steel
80	O-ring	2	-
80A	Front cover gasket	1	-
80B	O-ring	2	-
80C	O-ring	1	NBR
80D	O-ring	2	-
82	Splash ring	2	EPDM
84	Blanking plug	1	72 NBR
85	Oil plug	1	Plastic
86	Peephole	1	Plastic
87	Bleeder	2	Plastic
88	Lip seal	1	72 NBR
89	Lip seal	2	72 NBR

8.13. BLK 5

8.13.1. Exploded view

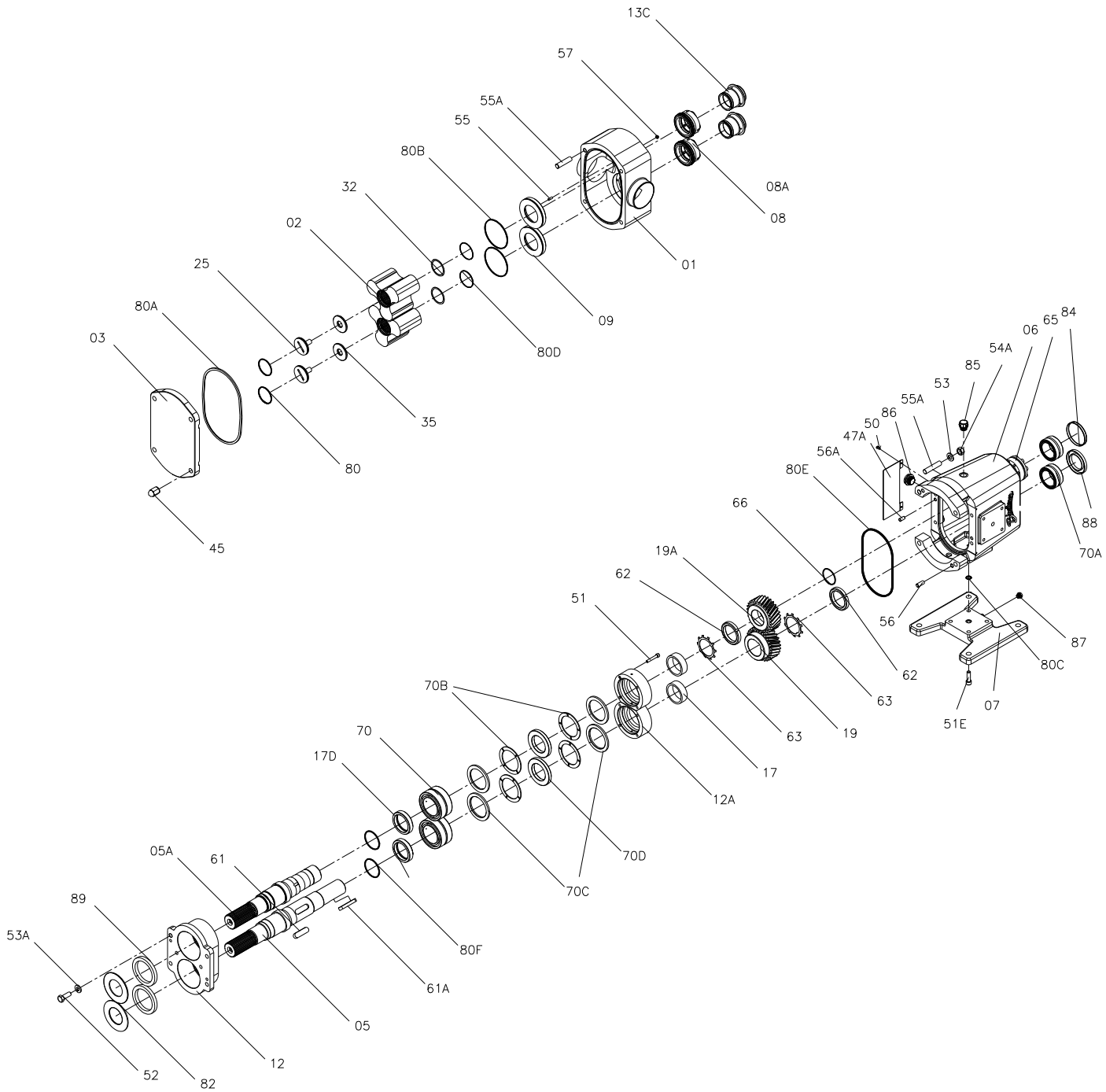

8.13.2. Spare parts

Pos.	Description	Quant.	Material
01	Rotor case BLK 5-78-12 BLK 5-116-7	1	AISI 316L
02	Rotor BLK 5-78-12 BLK 5-116-7	2	AISI 316L
03	Front cover	1	AISI 316L
05	Drive shaft	1	AISI 329
05A	Driven shaft	1	AISI 329
06	Gear case	1	GG-22
07	Support, horizontal ported	1	AISI 304
08	Mechanical seal, rotary part	2	Sil/70 EPDM
08A	Mechanical seal, stationary part	2	Graf/70 EPDM
09	Seal cover	2	AISI 316L
12	Bearing cover	1	GG-22
12A	Bearing stop flange	2	GG-22
13	Sleeve, seal	2	AISI 316L
17	Drive shaft bushing	2	ST-52
17D	Lip seal bushing	2	AISI-304
19	Driver shaft gear	1	F-115
19A	Driven shaft gear	1	F-115
25	Lobe screw BLK 5-78-12 BLK 5-116-7	2	AISI 316L
32	Shim	2	St. St.
35	Rotor washer	2	AISI 316L
45	Wing nut	4	AISI 304
47A	Protector	2	PET-Plus
50	Screw	4	A2
51	Allen screw	8	8.8
51E	Allen screw	4	A2
52	Hex. screw	4	A2
53	Flat washer	4	A2
53A	Grower washer	4	Steel
54A	Hexagonal nut	4	A2
55	Stud	4	A2
55A	Stud	8	A2
55B	Stud	4	
56	Pin	2	F-522
56A	Pin	2	F-522
57	Self-locking nut	4	A2
61	Key	1	F-114
61A	Key	1	AISI 304
62	Safety nut	2	Steel
63	Safety washer	2	Steel
65	Conical tightening ring	1	Steel
66	Circlip	1	Steel
70	Roller bearings	2	Steel
70A	Needle bearings	2	Steel
70B	Needle thrust crown	2	Steel
70C	Axial disc	2	Steel
70D	Intermediate disc	2	Steel
80	O-ring	2	70 EPDM
80A	Front cover gasket	1	70 EPDM
80B	O-ring	2	70 EPDM
80C	O-ring	1	NBR
80D	O-ring	2	70 EPDM
80E	O-ring	1	70 MVQ
80F	O-ring	2	70 MVQ
82	Splash ring	2	EPDM
84	Blanking plug	1	72 NBR
85	Oil plug	1	Plastic
86	Peephole	1	Plastic
87	Bleeder	2	Plastic
88	Lip seal	1	72 NBR
89	Lip seal	2	72 NBR

8.14. RELIEF VALVE VALVE

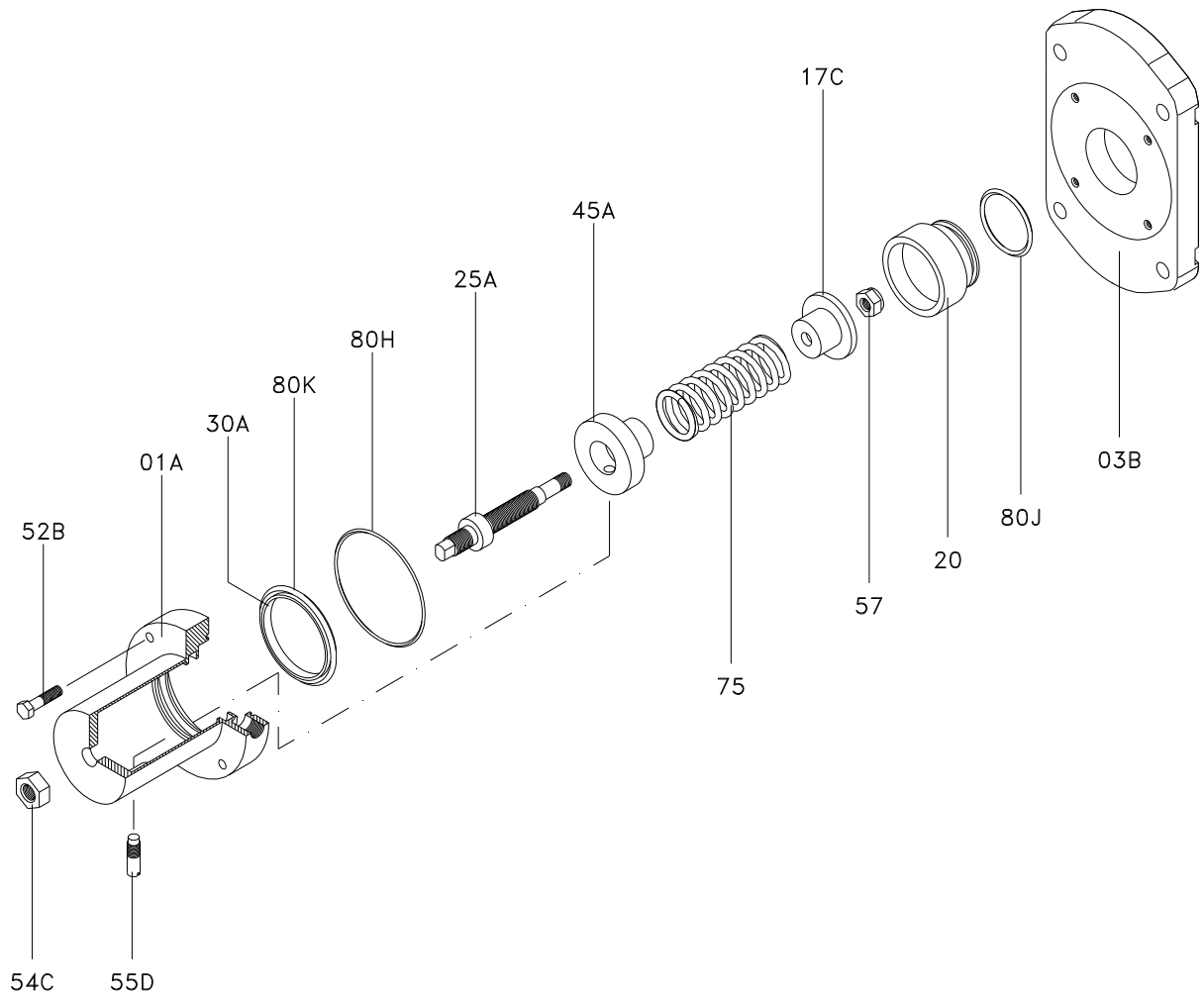

Position	Quantity	Description	Material
01A	1	Spring casing complete	AISI 304
03B	1	Pump cover for relief valve	AISI 316
17C	1	Spring plate	AISI 304
20	1	Piston	AISI 316
25A	1	Adjusting screw	AISI 304
30A	1	Guiding ring	PTFE
45A	1	Spring plate	AISI 304
52B	4	Hexagonal screw	A2
54C	1	Hexagonal nut	A2
55D	1	Locking pin	AISI 304
57	1	Self-locking nut	A2
75	1	Spring	AISI 301
80H	1	O-ring	EPDM
80J	1	O-ring	EPDM
80K	1	O-ring	EPDM

8.15. FRONT HEATING JACKET

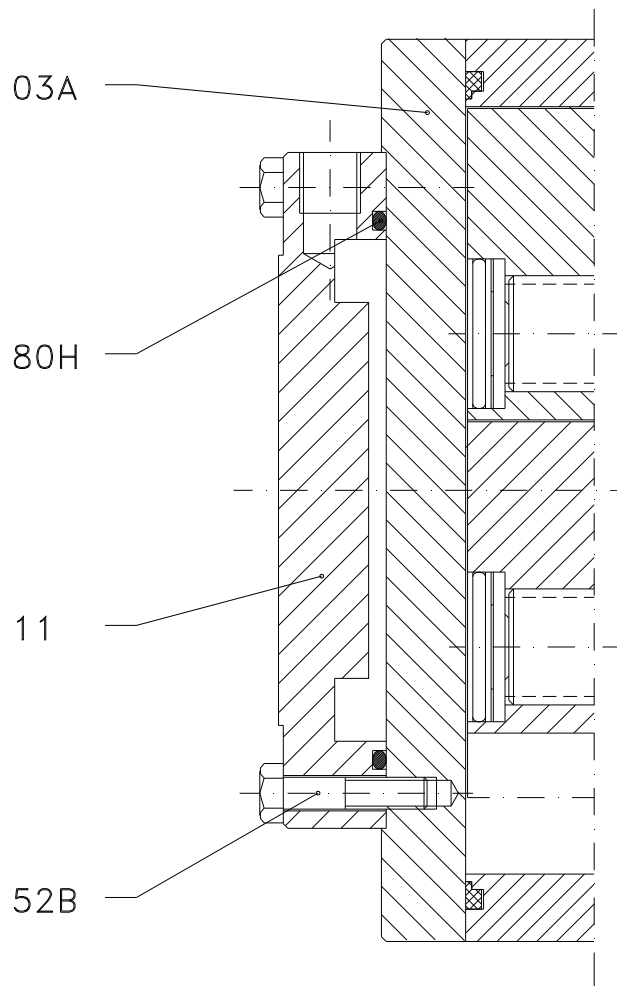

Position	Quantity	Description	Material
03A	1	Pump cover for heating jacket	AISI 316
11	1	Heating cover	AISI 304
52B	4	Hexagonal screw	A2
80H	1	O-ring	FPM

8.16. HEATING JACKET AROUND SHAFT SEALING

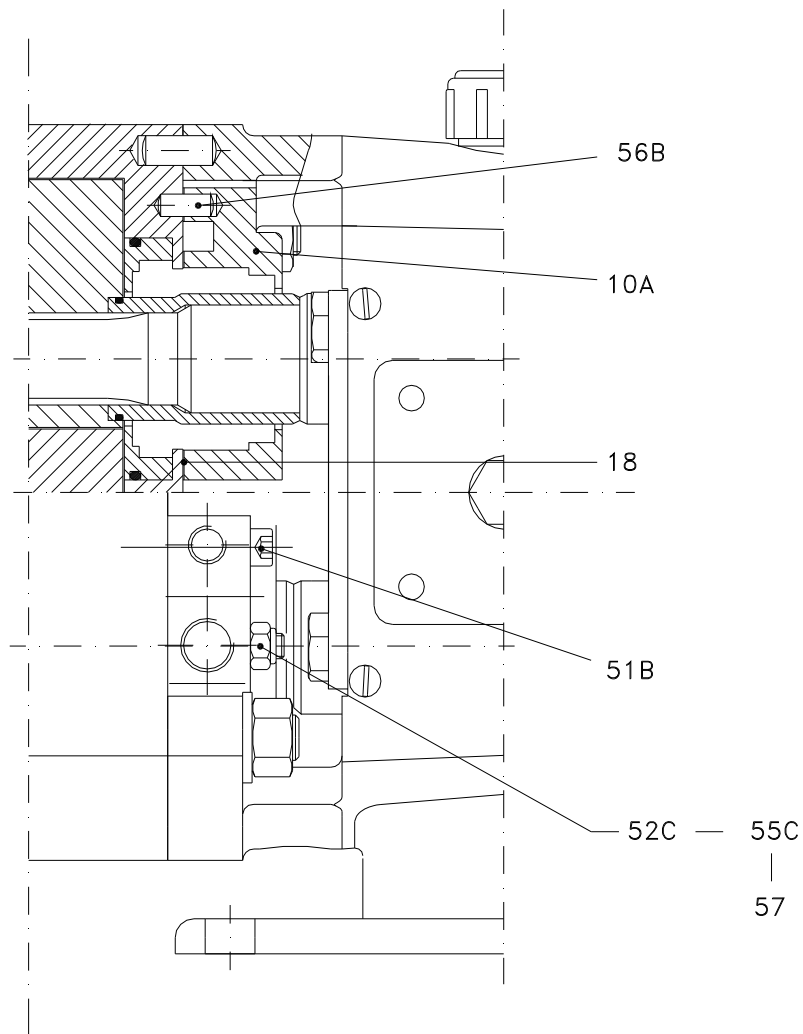

Position	Quantity	Description	Material
10A	2	Flushing cover with jacket	AISI 316
18	2	Gasket flushing	Graphite
51B	6	Allen screw -Gear Case 2-	A2
	8	Allen screw -Gear Case 3/4-	A2
52C	4	Hexagonal screw -Gear Case 2-	A2
55C	4	Stud -Gear Case 3/4-	A2
	8	Stud -Gear Case 5-	A2
56B	4	Pin	A2
57	4	Self-locking nut -Gear Case 3/4-	A2
	8	Self-locking nut -Gear Case 5-	A2