

# ***PUMPS A40 - AS40***

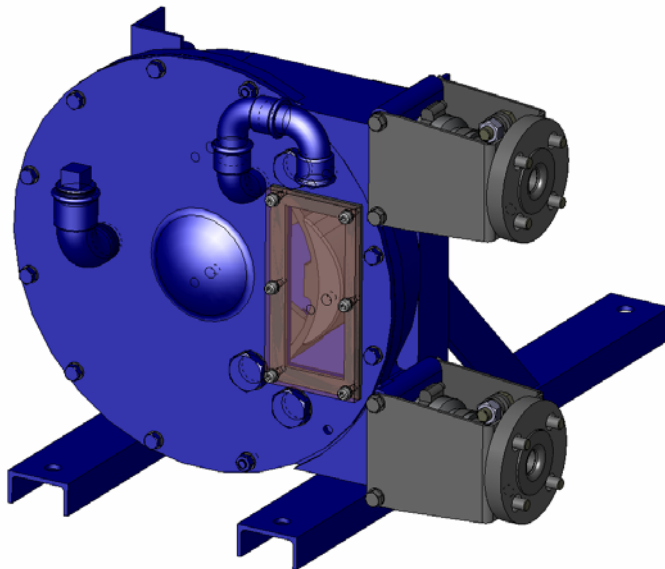

***INSTALLATION***

***OPERATION***

***MAINTENANCE***

# MOUVEX PERISTALTIC HOSE PUMP

## SAFETY INSTRUCTIONS, STORAGE, INSTALLATION AND MAINTENANCE

### MODELS : A40 - AS40

#### TECHNICAL CHARACTERISTICS

- Maximum pump speed acceptable\* :
  - **140 tr/mn (rpm)**
- Maximum running temperature \* :
  - **NR hose . . . . .70°C (158°F)**
  - **NBR hose . . . . .70°C (158°F)**
  - **EPDM hose . . . . .80°C (176°F)**
- Maximum discharge pressure acceptable\* :
  - **15 bar (217,5 PSI)**
- Minimum suction pressure acceptable :
  - **-0,6 bar (-8,7 PSI)**
- Cylinder capacity :
  - **0,861 dm<sup>3</sup> (0,227 gallon)**

\* CAUTION : Functional limitations indicated are strictly dependent on each other, refer to TECHNICAL DATA § to define the limits of use for your installation.

Pump n°:

Date of bringing into service :

#### SAFETY INFORMATIONS



#### This is a SAFETY ALERT SYMBOL

When you see this symbol on the product, or in the manual, look for one of the following signal words and be alert to the potential for personal injury, death or major property damage.



Warns of hazards that **WILL** cause serious personal injury, death or major property damage



Warns of hazards that **CAN** cause serious personal injury, death or major property damage.



Warns of hazards that **CAN** cause personal injury or property damage.

#### NOTICE

Indicates special instructions which are very important and must be followed.

#### NOTES

The numbers written in bold characters after part names correspond to reference numbers in the spare parts lists..

Photos and drawings used in this IOM are not contractual.

#### SUMMARY

#### Page

<b>1. OVERALL DIMENSIONS . . . . .</b>	<b>3</b>
1.1 A40 model . . . . .	3
1.2 AS40 model . . . . .	4
<b>2. INSTALLATION . . . . .</b>	<b>5</b>
2.1 Operator principle . . . . .	5
2.2 Hose compression . . . . .	5
2.3 Pumped liquid . . . . .	5
2.4 Pipe diameters . . . . .	5
2.5 Piping assembly . . . . .	5
2.6 Direction of rotation . . . . .	6
2.7 Liquids containing a high proportion of particles . . . . .	6
2.8 Working with vacuum on the suction side . . . . .	6
2.9 Handling . . . . .	6
2.10 Pump location . . . . .	6
2.11 Anchoring the pump units . . . . .	7
2.12 Alignment of motor / pump and reduction gearbox / pump shafts . . . . .	7
2.13 Electric motors . . . . .	7
<b>3. USE . . . . .</b>	<b>8</b>
3.1 Pump storage . . . . .	8
3.2 Hose storage . . . . .	8
3.3 Pumping hot products . . . . .	8
3.4 Pump filled with product at shutdown . . . . .	8
3.5 Starting-up the pump . . . . .	8
3.6 Shutting down the pump . . . . .	8
3.7 In the event of the hose breaking . . . . .	8
<b>4. MAINTENANCE OPERATIONS . . . . .</b>	<b>9</b>
4.1 Replacing the hose . . . . .	9
4.2 Re-assembling and disassembling the wheel . . . . .	12
4.3 Replacing the shoes . . . . .	12
4.4 Setting of pump at service pressure needed . . . . .	13
<b>5. TECHNICAL SPECIFICATIONS . . . . .</b>	<b>15</b>
5.1 Characteristics . . . . .	15
5.2 Shimming the shoes . . . . .	15
<b>6. MAINTENANCE . . . . .</b>	<b>16</b>
6.1 Lubrication . . . . .	16
6.2 Hose . . . . .	16
6.3 Seals . . . . .	16
<b>7. TROUBLESHOOTING . . . . .</b>	<b>17</b>

#### NOTES :

The MOUVEX peristaltic hose pumps **MUST** be installed on systems specially designed by qualified staff. Installation **MUST** comply with local standards, national rules and safety regulations.

This manual is designed for installation and start-up of the peristaltic hose pumps. It **MUST** be supplied with the pump.

Maintenance of the peristaltic pumps must be carried out **ONLY** by qualified personnel. This operation must comply with local and national regulations as well as safety standards.

Read the whole manual and all the instructions and precautions, **BEFORE** using any MOUVEX pumps.

Do not remove any warning and use stickers from the pumps.

# 1. OVERALL DIMENSIONS

## 1.1 A40 MODEL

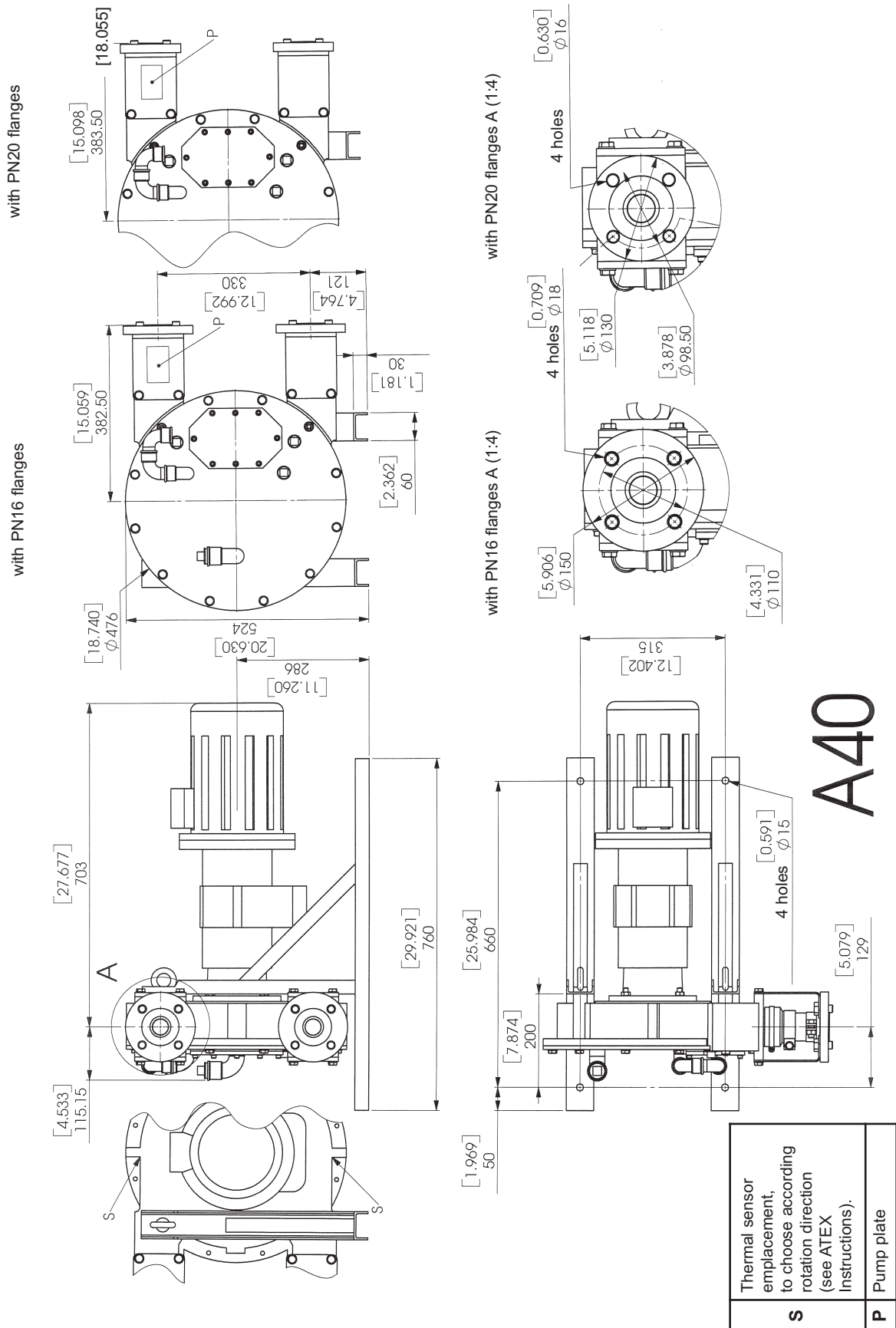

# 1. OVERALL DIMENSIONS (continued)

## 1.2 AS40 MODEL

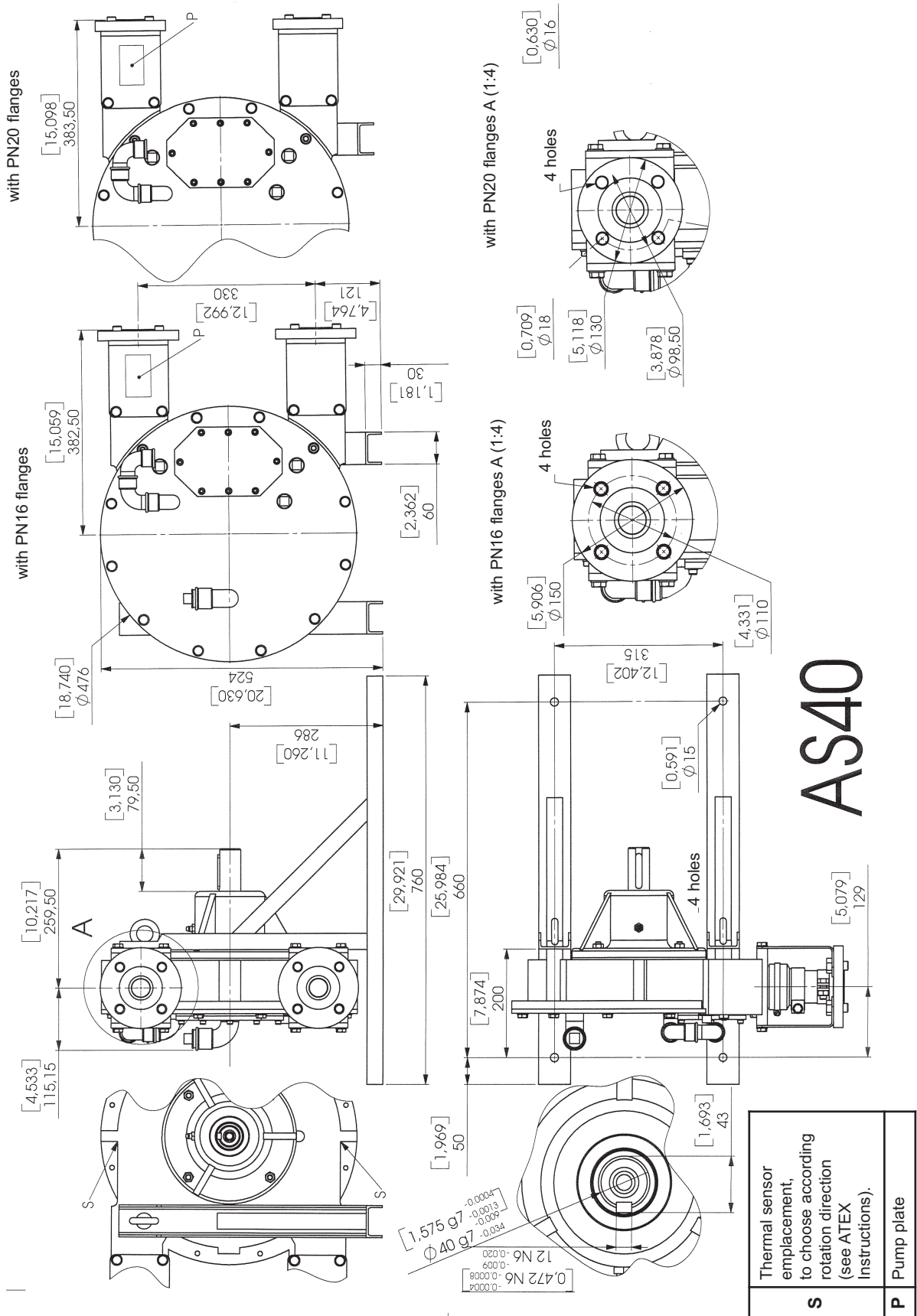

## 2. INSTALLATION

### 2.1 OPERATOR PRINCIPLE

The pump operates by alternating contraction and relaxation of a specially designed elastomeric hose.

Two shoes attached 180° apart to a central wheel compress the hose against the pump body in a fluidtight manner.

Rotation of the wheel causes a flow by displacing the product into the hose.

The pump body is filled with a special lubricant allowing shoes to slide easily over the hose, which avoids overheating.

### 2.2 HOSE COMPRESSION

Performance and durability of the hose are guaranteed by inserting an adequate number of shims under the two shoes (see § SHIMMING THE SHOES).

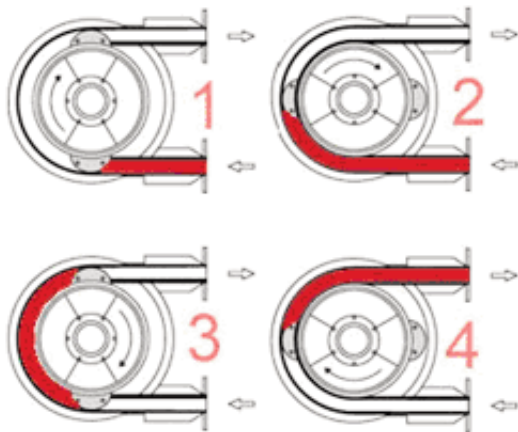

### 2.3 PUMPED LIQUID

Under normal operation, the pumped liquid is only in contact with the hose and the inserts which must be compatible with it.

Three different quality elastomeric hoses are available :

- NR (natural rubber) . . . . . White marking
- NBR (perbunan or buna) . . . . . Yellow marking
- EPDM . . . . . Red marking

Inserts are available in AISI 316 stainless steel, in polypropylene (PPH) and in polyfluoride vinylidene (PVDF).

This pumping technology is specially suited to handle abrasive products.

During the compression stage, abrasive particles may penetrate the hose wall without damaging it. Immediately after, these particles are released into the liquid (the size of particles does not however have to exceed 15 % of the internal diameter of the hose).

You can contact our Technical Services at any time to ask for the information you require.

### 2.4 PIPE DIAMETERS

The location of the pump in the transfer or recycling circuit should always be determined so as to reduce the suction height and length of the piping as much as possible.

The diameter of the pipes must be determined as a function of their length on the one hand, and the flow and viscosity of the product on the other, so that head loss remains within design limits. Therefore it is difficult to give general and precise directions.

However, we recall that it is never prejudicial to plan for wide piping diameters, particularly regarding the intake.

For the discharge, it is also possible to plan for a diameter equal to that of the pump's orifices, and on the intake, for a wider diameter if suction is very strong. In the case of viscous products, the determination of this diameter is very important since the variation of head loss is proportional to the viscosity and inversely proportional to the power of 4<sup>th</sup> of the diameter. Therefore a small reduction of piping diameter can have major consequences. Our Technical Services are always available to provide you with precise data if you give them accurate information or, better still, the installation plans.

### 2.5 PIPING ASSEMBLY



**FAILURE TO RELIEVE THE SYSTEM PRESSURE PRIOR TO PERFORMING ANY WORK ON THE PUMP OR THE INSTALLATION CAN CAUSE PERSONAL INJURY OR PROPERTY DAMAGE.**

Wherever possible, siphons and reverse slopes in the suction piping must be avoided and all the gaskets must be installed with great care to avoid air from entering the piping.

The elbows must always have a large radius and must not be assembled too close to the pump flanges, at the inlet as well as the outlet side.

The stresses exerted by the piping on the pump can deform the pump parts, increase wear, misalign the bearings and even cause parts to break.

The pipes must be designed to allow thermal expansion and contraction and be firmly secured (the use of flexible hoses and expansion loops is recommended).

We recommend placing isolating valves close to the pump flanges to permit dismantling and replacement without having to drain the installation. These valves should have the same diameter as the pipes and, by preference, be a full bore model.

## 2. INSTALLATION (continued)

If the liquid may freeze or solidify, prepare for draining the piping by installing drain taps at the low points and air vents at the high points.

In the case of a very high intake or if you wish to prevent the piping from emptying at shutdown, you can install a foot valve. It should have a large diameter so as not to generate additional head loss.

### 2.6 DIRECTION OF ROTATION



**FAILURE TO RELIEVE THE SYSTEM PRESSURE PRIOR TO PERFORMING ANY WORK ON THE PUMP OR THE INSTALLATION CAN CAUSE PERSONAL INJURY OR PROPERTY DAMAGE.**

The MOUVEX pump is reversible, this allows it to always circulate the liquid in the desired direction by choosing the corresponding direction of rotation.

The intake and discharge sides are determined as follows :

When an observer faces the shaft, if rotation takes place clockwise, the intake is on the bottom, on the contrary if the rotation is anticlockwise, the intake is on the top.

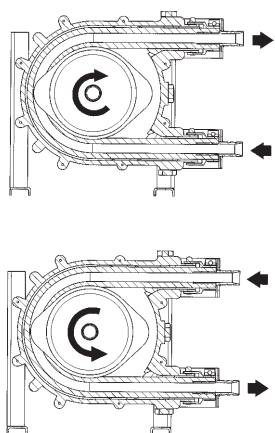

Clockwise rotation

### 2.7 LIQUIDS CONTAINING A HIGH PROPORTION OF PARTICLES

In the case where the pumped fluid contains particles, use the upper flange as the inlet flange.

This facilitates discharge of the sediments formed by the build-up of the particles contained in the fluid, so this reduces friction between the hose and the shoes.

Therefore, the pump may be re-started more easily.

### 2.8 WORKING WITH VACCUM ON THE SUCTION SIDE

Because of the operating principle of the pump, using it with suction pressure lower than the atmospheric pressure will cause a resulting loss of flow more or less in line with the conditions of the application (hose material, rotation speed, temperature, etc.).

In order for the pump to generate the normally required flow, MOUVEX recommends using a vacuum draw kit inside the body of the pump.

In all cases, suction pressure must not be lower than -0.6 bar (-8,7 PSI).

If a vacuum draw kit is not used on an ABAQUE pump operating with suction pressure lower than atmospheric pressure, MOUVEX no longer guarantees the performance of the pump.

### 2.9 HANDLING

The maximum weight of the pump is :

- A40 .....144 kg (318 lb)
- AS40 .....102 kg (225 lb)

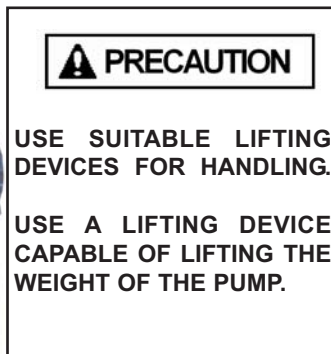

### 2.10 PUMP LOCATION

Provide sufficient clearance around the pump for maintenance operations.

Particularly, make sure that there is sufficient clearance for replacing the hose; the distance between the pump flanges and the closest obstacle must allow the hose to be removed, as shown below :

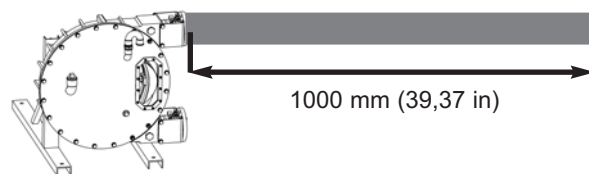

## 2. INSTALLATION (continued)

### 2.11 ANCHORING THE PUMP UNITS

The correct seating of the pump is vital for its efficient operation and its longevity.

The surface must be resistant enough to absorb the stresses due to the pump unit without deformation.

In the case where the unit is fastened by anchor lugs or bolts, it must be carefully wedged to prevent any deformation of the chassis when tightening the bolts.

### 2.12 ALIGNMENT OF MOTOR / PUMP AND REDUCTION GEARBOX / PUMP SHAFTS

<b>⚠ WARNING</b>

Do not operate without guard in place.

OPERATION WITHOUT THE SHAFT PROTECTOR CAN CAUSE SERIOUS PERSONAL INJURY, MAJOR PROPERTY DAMAGE, OR DEATH.

<b>⚠ WARNING</b>

Dangerous voltage. Can cause injury and death.

DISCONNECT THE ELECTRICITY SUPPLY BEFORE ANY MAINTENANCE OPERATION.

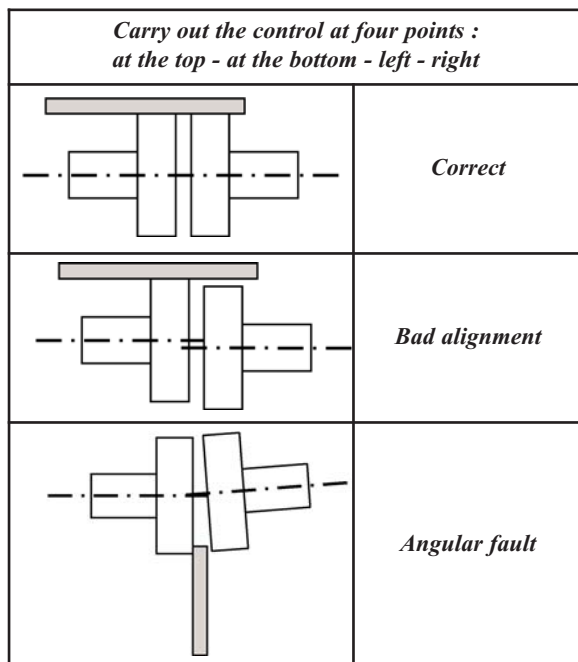
To check the alignment and coupling, use a set square to control the axial misalignment and feeler gauges for angular misalignment.



It is important to control the alignment at every step of installation in order to ensure that none of these steps generates stress on the pump unit or the pump itself :

- after fastening on foundations
- after fastening the piping
- after the pump has operated at normal operating temperature.

#### REMINDER :

Do not rely on the flexible coupling to compensate for misalignment.

### 2.13 ELECTRIC MOTORS

<b>⚠ WARNING</b>

Dangerous voltage. Can cause injury and death.

DISCONNECT THE ELECTRICITY SUPPLY BEFORE ANY MAINTENANCE OPERATION.

Check that the supply voltage matches the indications on the motor rating plate.

Comply with the wiring diagram, make sure the wires are rated for the power and take care with the contacts which must be thoroughly tightened.

The motors must be protected by appropriate circuit breakers and fuses.

Connect the regulatory ground connections.

Check the direction of rotation :

<b>⚠ WARNING</b>

Do not operate without guard in place.

OPERATION WITHOUT THE SHAFT PROTECTOR CAN CAUSE SERIOUS PERSONAL INJURY, MAJOR PROPERTY DAMAGE, OR DEATH.

This fundamental checking of the pump must be done without any product, with the inlet and outlet circuit open to the air, for example, to avoid any risk of an unexpected pressure rise. Start the pump empty to check the correct operation of the connections and check that the direction of rotation corresponds to installation's inlet and outlet direction. Follow the instructions below if necessary to change the direction of rotation.

Three phase motor : switch any two wires of the current supply.

Two phase motor : switch the two wires of the same phase.

Single phase motor : comply with the instructions of the manual supplied with the motor.

## 3. USE

### 3.1 PUMP STORAGE

If the pump is inactive for more than 3 months, remove the hose or the shoes.

If you do not wish to remove the hose, operate the pump for 5 minutes once a week.

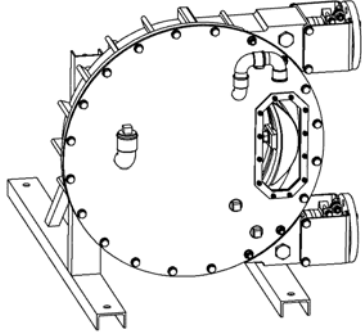

**NOTE :**

Check that the wheel is always in such a position that one of the shoes can be seen through the window.

### 3.2 HOSE STORAGE

Hose shelf life is limited to two years from the date of purchase.

The hoses must be stored in a cool place protected from light. Exposure to ultraviolet rays accelerates deterioration of the material, thus reducing shelf life.

### 3.3 PUMPING HOT PRODUCTS



THE SURFACES OF THE PUMP CAN BE AT A TEMPERATURE LIABLE TO CAUSE INJURY OR SEVERE DAMAGE.

When pumping products at high temperatures, take care when starting the pump for the first time, tighten the bolts to compensate for expansion effects.

### 3.4 PUMP FILLED WITH PRODUCT AT SHUT-DOWN

In the case where the pumping circuit is situated between isolating valves and/or has a check valve, you must bear in mind the variations in temperature that can occur, leading in particular to the expansion of the product in the circuit. In this case, provide a means of releasing the expansion volume. The use of a relief valve can suffice for this function. The opening pressure of this valve must be compatible with the pressure allowed by the parts composing the circuit.

With products including particles that settle at shutdown, it is necessary to ensure that the consistency of the deposited products will not affect the start-up of the pump.

### 3.5 STARTING-UP THE PUMP

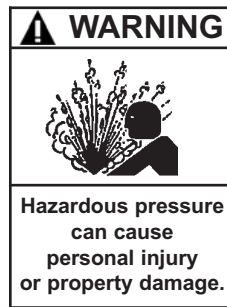

FAILURE TO RELIEVE THE SYSTEM PRESSURE PRIOR TO PERFORMING ANY WORK ON THE PUMP OR THE INSTALLATION CAN CAUSE PERSONAL INJURY OR PROPERTY DAMAGE.

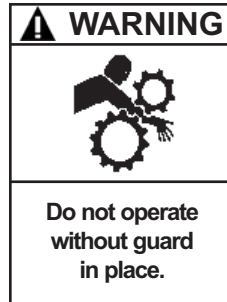

OPERATION WITHOUT THE SHAFT PROTECTOR CAN CAUSE SERIOUS PERSONAL INJURY, MAJOR PROPERTY DAMAGE, OR DEATH.

Before starting up the pump, always ensure that the pumping conditions are correct, with the corresponding valves open, especially the inlet valve.

Pump will not be in use when filled with lubricant and with temperatures below 0°C (32°F). Heating system must be put if such temperature conditions happen.

### 3.6 SHUTTING DOWN THE PUMP

When shutting down the pump, we recommend waiting for the pump to stop completely before closing the valves, especially the inlet valve.

### 3.7 IN THE EVENT OF THE HOSE BREAKING

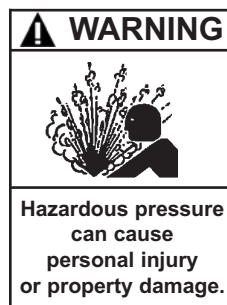

- HE CASING MAY BE FILLED WITH THE PUMPED FLUID.
- IF THE PUMP IS LOADED AT INTAKE OR DISCHARGE, ALL THE FLUID MAY BE EVACUATED THROUGH A HOLE IN THE HOSE IN THE PUMP BODY.

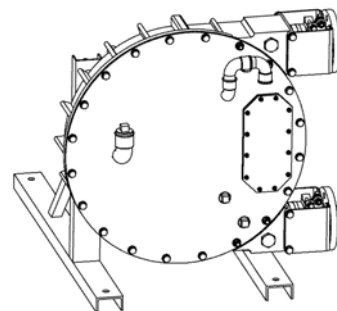

When the hose breaks, there is a risk that the lubricant may be contaminated by the pumped liquid.

## 4. MAINTENANCE OPERATIONS

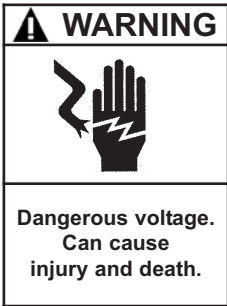

DISCONNECT THE ELECTRICITY SUPPLY BEFORE ANY MAINTENANCE OPERATION.

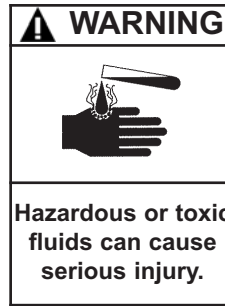

IF PUMPING HAZARDOUS OR TOXIC FLUIDS, THE SYSTEM MUST BE FLUSHED PRIOR TO PERFORMING ANY SERVICE OPERATION.



HANDLING THE PUMP WITHOUT THE COVER IN PLACE MAY CAUSE BODILY HARM, SERIOUS INJURY OR EVEN DEATH.

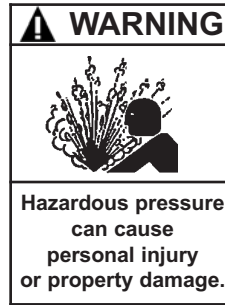

HYDRAULIC PRESSURE MUST BE FULLY RELEASED BEFORE MAINTENANCE OPERATIONS IN ORDER TO PREVENT PERSONAL INJURY OR PROPERTY DAMAGE.

Before opening the pump, always ensure that it has been drained and release the pressure it may contain. Make sure the isolation valves, if any, are closed.

### 4.1 REPLACING THE HOSE

#### 4.1.1 DISASSEMBLING THE HOSE

Disconnect the pump from inlet and discharge piping.

#### NOTES

To insure an optimal life cycle of the hose, it is recommended to replace the worn lubricant by some new lubricant during any replacement of hose.

The hose may contain a certain volume of the pumped fluid, but this will be expelled when restarting the pump.

Evacuation of this fluid may also be carried out by running the pump after having taken all the safety measures required for personal and property protection.

If maintenance of the pump is not carried on site, check the wheel rotation direction to determine the inlet and discharge ends.

If the pump is equipped with the "leak detection kit", which allows the pump to be stopped in the event of the hose breaking, first the capacitive sensor must be removed by unscrewing the large PVC ring. See the kit Instructions for further information.

1. Provide sufficient clearance as described in § PUMP LOCATION.
2. Drain the lubricant by unscrewing the level plug **57** and collect the lubricant in a tub.
3. Put the lubricant level plug **57** back in place.

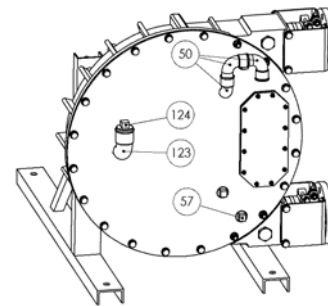

#### BOTTOM PORT

1. Place a tub under the hose boot **6** so that the lubricant in the pump body **1** is collected.
2. Untighten the hose clamp **9**.
3. Untighten the hose clamp **8**.
4. Untighten the hose clamp **7**.
5. Remove the insert **12** with the flange **47**, by pulling the flange **47**.
6. Untighten the 4 screws **48**, remove the washers **49** and the brackets **18**.
7. Remove the hose clamp **9**.
8. Remove the hose clamp **8**.
9. Remove the hose clamp **7**.
10. Remove the nipple **6**.

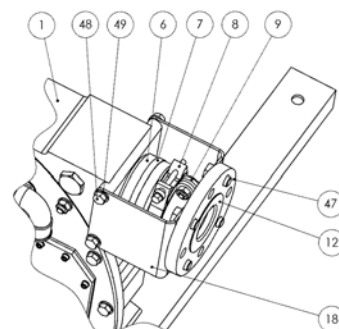

## 4. MAINTENANCE OPERATIONS (continued)

### TOP PORT

Repeat the steps described above from 2 to 10.



**THE HOSE CAN BE EXPELLED VIOLENTLY. BE SURE NO ONE IS IN FRONT OF PUMP PORTS.**

11. Operate the pump intermittently until the hose is completely out.

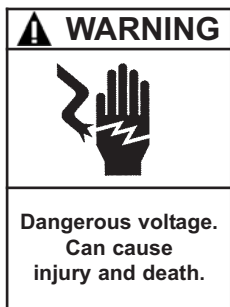

**DISCONNECT THE ELECTRICITY SUPPLY BEFORE ANY MAINTENANCE OPERATION.**

12. Disconnect the pump.

### 4.1.2 DISASSEMBLING THE COVER

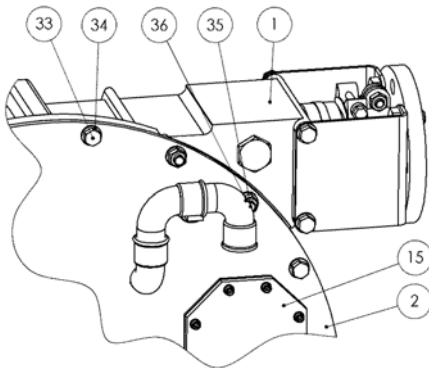

1. Loosen screws **33** and remove the washers **34**.
2. Loosen nuts **36** and remove the washers **35**.
3. Remove the cover **2**, be careful with the weight of the cover.



**BE CAREFUL WITH THE WEIGHT OF THE COVER WHEN IT IS BEING REMOVED.**

4. Wash the inside of the pump body **1** and the cover **2** with water or a cleaning product that is compatible with the pump materials. Also wash the wheel (front + back).

### NOTES

If the pump is not re-assembled immediately, dry unpainted surfaces and coat them with the pump lubricant in order to protect them against corrosion.

Dispose of the drained products in accordance with the rules and regulations in force.

### 4.1.3 ASSEMBLING THE COVER

1. After a visual inspection of the inside of the body and the wheel, lubricate all the internal parts of the casing with pump lubricant.
2. Assemble the cover **2**.
3. Place the washers **35**.
4. Tighten the nuts **36**.
5. Place the washers **34** and tighten the screws **33**.



**BE CAREFUL WITH THE WEIGHT OF THE PARTS WHEN THEY ARE BEING REMOVED.**

### 4.1.4 ASSEMBLING THE HOSE

1. Clean the hose **16** to eliminate any particles that may have adhered to it (gravel, etc.).
2. Generously coat the hose with lubricant.
3. Insert the loose end of the hose **16** in the inlet port of the pump body **1**.

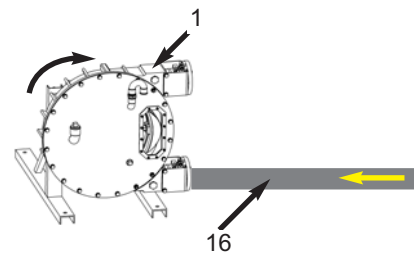

4. Operate the pump intermittently until the hose **16** is completely inserted in the body **1** so that the same length protrudes from both ports of the body.

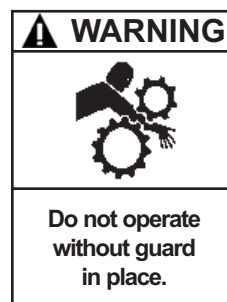

**NEVER INSERT THE HOSE OR RUN THE PUMP WITHOUT ITS COVER AND ITS WINDOW IN PLACE.**

## 4. MAINTENANCE OPERATIONS (continued)

### BOTTOM PORT

1. Check the state of the nipple **6** and change it if necessary.
2. Coat the nipple **6** with pump lubricant.
3. Slide the nipple **6** on the body port **1**.
4. Tighten the hose clamp **7** (take care on the direction of assembly of the hose clamp : it must be directed so that the part presenting a lively fish bone is side body). When starting the pump, check that there is no leakage next to the nipple **6**. Tight again the hose clamp **7** if needed.
5. Put the hose clamp **8**.
6. Put the hose clamp **9**.
7. Mount the brackets **18** with the washers **49** and the screws **48**.

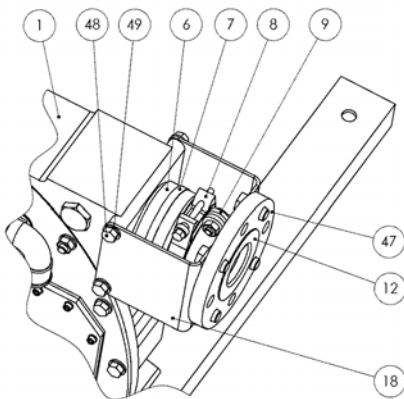

8. Mount flange **47** onto brackets **18** with the 2 screws **98** and 2 nuts **99** 180° apart.
9. Coat the outside of insert **12** with pump lubricant.
10. Coat the inside of hose **16** with pump lubricant.
11. Insert the insert **12** in the flange **47** and the hose **16** until the insert **12** is flat against the flange **47**.

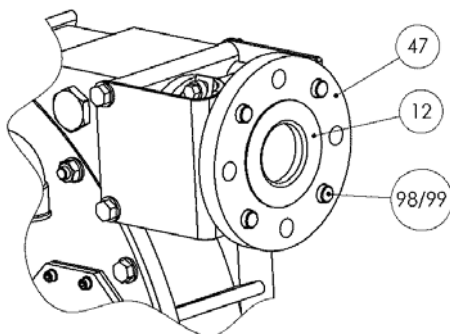

12. Tighten the hose clamp **8** (the screw should be tightened to the stop) onto the nipple **6**.
13. Tighten the hose clamp **9** (the screw should be tightened to the stop) onto the hose **16**.

### TOP PORT

Repeat the previous steps from 1 to 13.

### 4.1.5 FILLING WITH LUBRICANT

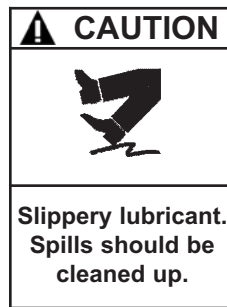

**THE PUMP LUBRICANT IS VERY SLIPPERY AND MAY CAUSE SERIOUS INJURY. ANY SPILLS MUST BE CLEANED UP.**

1. Loosen the plug **124**.
2. Fill the pump body with the lubricant (see § LUBRICATION).
3. Screw the plug **124**.

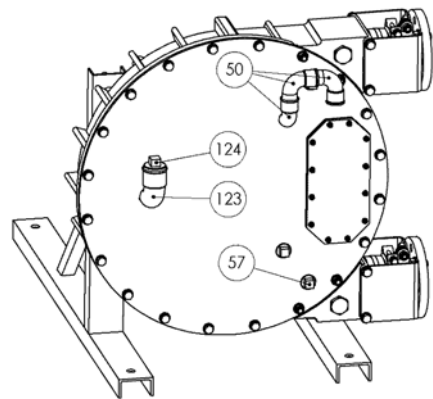

### NOTES

Handle the lubricant with care.

Wear suitable clothes and protect yourself from pump lubricant spatters.

Run the pump for a few minutes to check correct operation.

Connect the suction and discharge ports of the pump to the installation.

Put the puncture detection kit back in place, if the pump is equipped with one.

In the event that the breathing vent has been removed, check the installation direction for the existing back flow valve (the valve must allow air out and block it from entering).

## 4. MAINTENANCE OPERATIONS (continued)

### 4.2 RE-ASSEMBLING AND DISASSEMBLING THE WHEEL

Disassembly and reassembly of the wheel 3 are required when :

- Replacing the shaft seal 26.
- Performing a complete overhaul.
- Disassembling or replacing the bearing box or the reduction gear.

For disassemble the wheel 3, the pump hose must be removed (see § REPLACING THE HOSE).

#### 4.2.1 DISASSEMBLING THE WHEEL

1. Loosen screws 19a in the hub 19.
2. Tighten one of the screws 19a into the tapped hole of the hub 19 provided to pull out the cone.
3. Remove the wheel 3 by sliding it along the central axis.

**⚠ WARNING**



**BE CAREFUL WITH THE WEIGHT OF THE PARTS WHEN THEY ARE BEING REMOVED.**

The weight of the parts can be dangerous and may provoke bodily injuries or material damages.

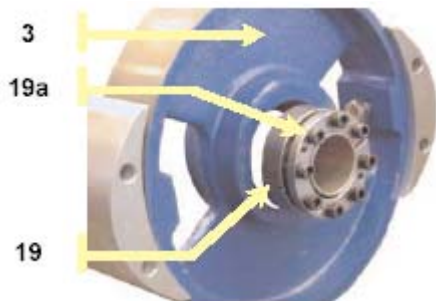

#### 4.2.2 ASSEMBLING THE WHEEL

1. Check the shaft seal 26. Replace when necessary, making sure that it is assembled so that the spring can be seen inside the pump body.
2. Check that the shoes have no dents or deep scratches that may quickly deteriorate the hose.
3. Insert the parts of the hub 19 in the wheel center.

**NOTE**

Screws 19a must not be tightened so the wheel assembly can freely slide along the axis.

4. Slide wheel 3 with its hub 19 on the axis.

5. Align wheel 3 with pump body 1 while keeping setting distance as indicated on the following diagram :

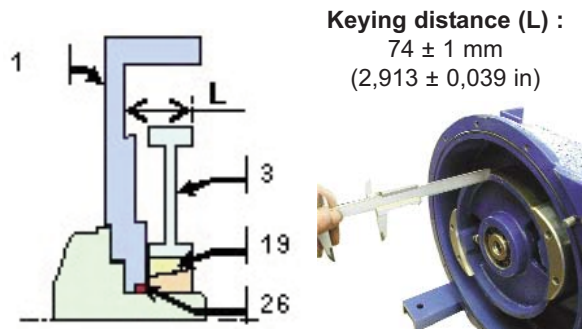

6. After checking that the expansible hub is properly centered with regard to the wheel thickness, gradually tighten screws 19a while keeping wheel alignment correct.

### 4.3 REPLACING THE SHOES

To replace the shoes 5, the pump hose must be disassembled (see § REPLACING THE HOSE).

#### 4.3.1 DISASSEMBLING THE SHOES

1. Partially untighten screw 28.
2. Remove the shims 4 from the shoe 5.

**NOTES**

Some shims cannot be removed by sliding them towards the outside. These special shims are installed by the manufacturer and must be kept for reassembly.

These shims can be recognized as they have 2 holes and have no notch like the other shims.

3. Completely loosen screw 28 and remove the washers 29.
4. Remove the shoe 5.
5. Remove the special shims 4.

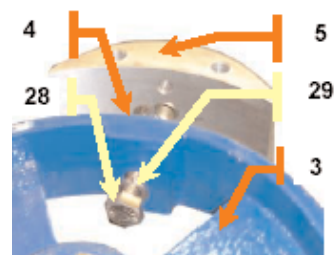

## 4. MAINTENANCE OPERATIONS (continued)

### 4.3.2 ASSEMBLING THE SHOES

1. Check that the shoes have no dents or deep scratches that may quickly deteriorate the hose.
2. Position the screw **28** with its washer **29** around the wheel **3**.
3. Slip the special shims **4**.
4. Position the shoe **5**.
5. Partially tighten the screw **28**.
6. Insert a suitable number of shims in accordance with the desired service pressure (see § SHIMMING THE SHOES).
7. Tighten the screw **28**, check that the shoe **5** is correctly aligned with the wheel **3**.

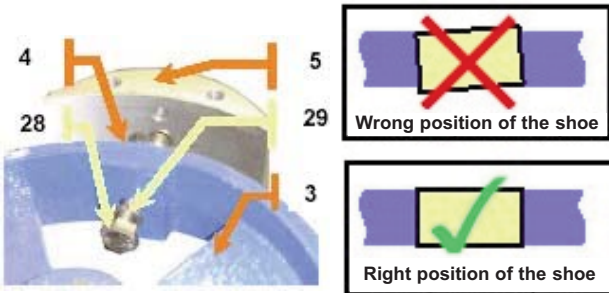

### 4.4 SETTING OF PUMP AT SERVICE PRESSURE NEEDED

Shims may have to be added under the shoes (see § SHIMMING THE SHOES).

The cover **2** need not be removed.

#### 4.4.1 ADDING OR TAKING OFF SHIMS

##### First shoe :

1. Position the shoe **5** facing the window **15**. If the shoe is not correctly positioned, operate the pump intermittently until the shoe **5** can be seen through the window **15**.
2. Switch off the electric power supply before any operation in order to prevent the pump starting unexpectedly.

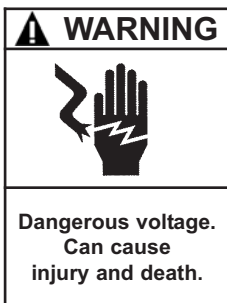

**DISCONNECT THE ELECTRICITY SUPPLY BEFORE ANY MAINTENANCE OPERATION.**

3. Drain the pump of his lubricant following the instructions of the § DISASSEMBLING THE HOSE.

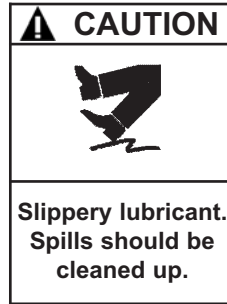

**THE PUMP LUBRICANT IS VERY SLIPPERY AND MAY CAUSE SERIOUS INJURY. ANY SPILLS MUST BE CLEANED UP.**

4. Loosen the screws **37** and remove the washers **38**.
5. Remove the window **15**.
6. Remove the window seal **46**.
7. Partially untighten the screw **28**.

**NOTE**  
Do not loosen the shoe screw **28** completely.

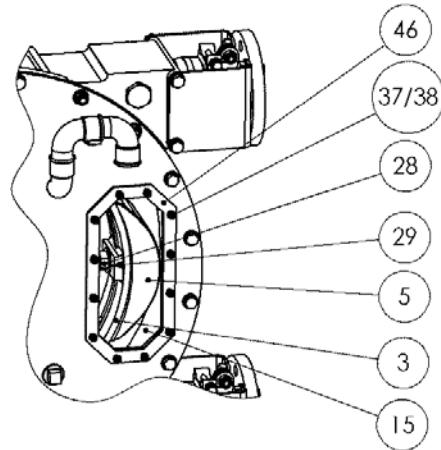

8. Place the suitable number of shims **4** (see § SHIMMING THE SHOES).
9. Tighten the screw **28**, check that the shoe **5** is correctly aligned with the wheel **3** (see § ASSEMBLING THE SHOES).
10. Check the window seal **46**, change it if necessary.
11. Position the window **15** with its seal **46**.
12. Tighten the screws **37**, with their washers **38**. Once the screws are tightened, the seal must be squeezed all over.
13. Switch on electric power supply.

##### Second shoe :

Repeat the previous steps from 1 to 13.

**NOTE**  
There must be the same number of shims under each shoe.

## 4. MAINTENANCE OPERATIONS (continued)

### 4.4.2 FILLING WITH LUBRICANT

1. Unscrew the plug **124**.
2. Fill the pump body with lubricant, as indicated in § LUBRICATION.
3. Screw the plug **124**.

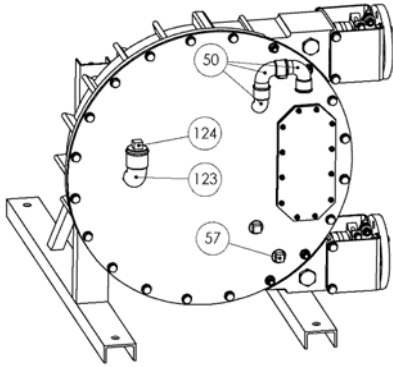

### CAUTION



THE PUMP LUBRICANT IS VERY SLIPPERY AND MAY CAUSE SERIOUS INJURY. ANY SPILLS MUST BE CLEANED UP.

Slippery lubricant.  
Spills should be cleaned up.

### NOTES

Handle the lubricant with care.

Wear suitable clothes and protect yourself from pump lubricant spatters.

## 5. TECHNICAL SPECIFICATIONS

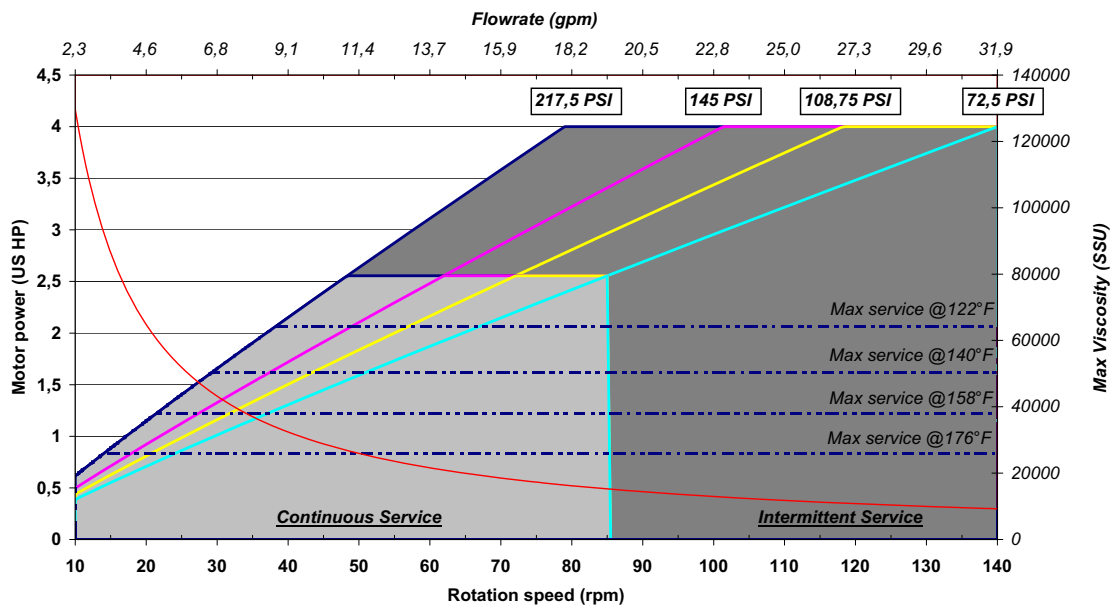
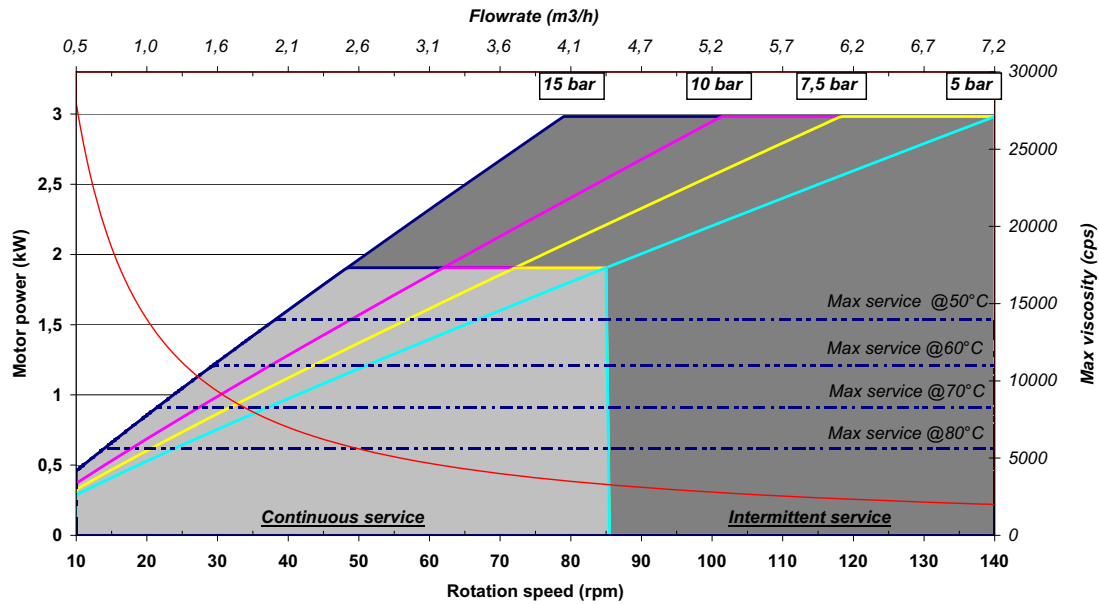

ATEX certified Abaque pumps have specific limits for use.  
Refer to corresponding Instructions Manual for more informations.

### 5.1 CHARACTERISTICS

Light grey area : Continuous service (24h/24).

Dark grey area : Intermittent service (continually for 2 hours then stopped for 1 hour).

The flow rates shown have been obtained by pumping water at room temperature.

Above the limit of Max service at 50°C (122°F), the maximum temperature of liquid is 40°C (104°F).

### 5.2 SHIMMING THE SHOES

Suitable shimming of the shoes lengthens the service life of the hose.

#### 5.2.1 SERVICE PRESSURE SPECIFIED AT ORDER

If the service pressure has been specified at order, the pump is shimmed in the factory to allow pump running at specified service pressure. No additional shimming is needed.

#### 5.2.2 SERVICE PRESSURE NOT SPECIFIED AT ORDER

If the service pressure has not been specified at order, the pump is pre-configured by the manufacturer for a service pressure up to 5 bar (72,5 PSI).

For higher pressure values, one or more shims must be placed under the shoes, as indicated in the instructions 1101-Q00 "SETTING THE HOSE COMPRESSION".

For adding the shims, see § SETTING OF PUMP AT SERVICE PRESSURE NEEDED.

## 6. MAINTENANCE

### 6.1 LUBRICATION

The hose is lubricated with a special mixture. MOUVEX lubricant is recommended to lengthen the service life of the hose.

It is recommended to change the lubricant when :

- Replacing the hose.
- Replacing the hose due to maintenance operation.
- After 2000 hours of operation.

Amount of lubricant required :

A40 and AS40 pumps require 2,5 liters of lubricant.
--

The minimum working or storage temperature for the pump lubricant is 0°C (32°F).

If the temperature is lower, 5% ethylene glycol may be added to the MOUVEX lubricant. Such lower temperature conditions require specific procedures to be implemented for the hose and the pump operation (see § STARTING-UP THE PUMP).

### 6.2 HOSE

Some pumped liquids require the hose to be cleaned after each operation to prevent solidification of the fluid inside the hose.

The hose can be easily washed with a cleaning agent that is compatible with the hose material and the pumped product.

It is recommended that the hose be monitored so that it can be replaced before any breakdown should occur. Preventive replacement is advisable.

Temperature threshold values for the liquid pumped depend directly on the materials that make up the hose.

Refer to technical characteristics on the cover page for the corresponding values.

It is important to note that the temperature of the pumped liquid influences the limits of use of the pump and that a rise of the temperature of the pumped liquid has to come along with a modification of the service pressure / of the speed of rotation so as to respect the limits defined in § TECHNICAL SPECIFICATIONS and eventually of a modification of the shimming of the shoe as specified in the § SHIMMING THE SHOES.

When required, you can contact our Technical Services at any time to ask for the information you require.

### 6.3 SEALS

#### 6.3.1 SHAFT SEAL 26

The shaft seal **26** must be replaced if lubricant leakage is observed near the drip strip, located on the rear side of the pump body **1**.

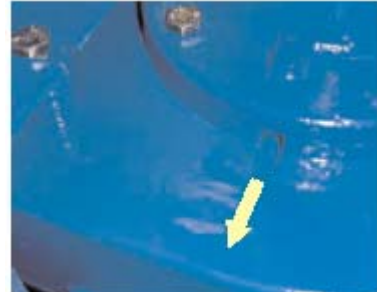

#### 6.3.2 COVER SEAL 10

The cover seal **10** must be checked when removing the cover **2** and replaced if necessary (see § DISASSEMBLING THE COVER).

#### 6.3.3 WINDOW SEAL 46

The window seal **46** must be checked when removing the window **15** and replaced if necessary (see § SETTING OF PUMP AT SERVICE PRESSURE NEEDED).

## 7. TROUBLESHOOTING

PROBLEM	POSSIBLE CAUSE	SOLUTION
<b>THE PUMP WILL NOT START</b>	Electric power supply failure.	Check the connections : <ul style="list-style-type: none"> <li>• There must be 3 phases</li> <li>• The connections are suitable for the voltage (delta-star)</li> <li>• If possible, check the parameters for the different motor frequencies (starting torque, power input...)</li> </ul>
	When the pump has not been used for a long period of time, the boss of the wheel has not been dipped in the lubricant. As it has not been lubricated, it causes a lot of resistance on start up.	Operate the pump intermittently to try to free the wheel but do not be too insistent to prevent the reduction gear from being damaged. If the wheel remains stuck, contact your local dealer for instructions.
	Sediments or other substances have built up inside the hose and are blocking the pump.	Reverse the pump rotation direction or disassemble the hose. If the wheel remains stuck, contact your local dealer for instructions.
<b>WEAK FLOW</b>	The inlet or discharge valve is partially closed.	Open the inlet or discharge valve.
	Air is entering the inlet piping.	Check the inlet line.
	The pumped liquid is too viscous. Significant pressure drop at inlet.	Check the inlet line (see § 2.4 PIPE DIAMETERS).
	The pump hose is damaged.	Replace the hose (see § 4.1 REPLACING THE HOSE).
<b>TEMPERATURE TOO HIGH</b>	The lubricant is not suitable.	Empty the pump body and replace the lubricant with one that is recommended by MOUVEX.
	The lubricant is dirty or too old.	Empty the pump body and replace the lubricant with a new MOUVEX lubricant.
	Temperature of the pumped fluid is too high.	Check the maximum fluid temperature allowed for the hose material.
	Pump speed too high.	Reduce speed.
<b>HOSE LIFE TOO SHORT</b>	Lubricant is not suitable.	Empty the pump body and replace the lubricant with one that is recommended by MOUVEX.
	Chemical incompatibility between the hose and the pumped fluid.	Check the compatibility of the hose with the fluid and replace the hose with another one made of suitable material.
	Temperature of pumped fluid too high.	Check the maximum temperature permitted for the hose.
	The discharge pressure is too high.	Check the maximum pressure allowed for the pump. Reduce pressure drop at discharge.
	Pump speed is too high.	Reduce speed.
<b>THE HOSE IS PULLED INTO THE PUMP BODY AT INLET</b>	The pumped fluid contains impurities or sediments.	Reverse the pump rotation direction and use the upper port for inlet.
	Clamp 9 is not sufficiently tightened.	Retighten the clamp.